

# Technical Rationale for Reliability Standard

## PRC-028-1

July 2024

### **PRC-028-1 – Disturbance Monitoring and Reporting Requirements for Inverter Based Resources**

The recent disturbance reports (e.g., Blue Cut Fire, Canyon 2 Fire, Odessa disturbances) have identified a need for disturbance monitoring for Inverter-Based Resources to aid with event analysis, performance monitoring, and disturbance-based Inverter-Based Resource model validation. These disturbance reports are recommended to install disturbance monitoring equipment (DME) at wind and solar photovoltaic (PV) resources to ensure adequate data is available for event analysis, performance monitoring, and validating Inverter-Based Resource models. The recommendation included plant-level high resolution oscillography data, plant SCADA data with a resolution of one second, and inverter level of sequence of events recording data that include all fault codes and high resolution oscillography data. In a first version of this standard, only SER data at inverter level data is required. For the purposes of this standard, the inverter, converter, wind turbine generator, or high voltage direct current converter connecting generating resource to alternating current Transmission network is referred to as an IBR unit.

The purpose of Reliability Standard PRC-002 is to capture event data to understand large scale system disturbances occurring on the Bulk Electric System (BES). Even with changing resource mix, the Reliability Standard PRC-002 serves the purpose. The recent disturbance analyses of events involving inverter-based resources (e.g., Blue Cut Fire, Canyon 2 Fire, Odessa disturbances) have demonstrated that Inverter-Based Resource's response to a normally cleared few cycle fault is undesirable and poses risk to system reliability. All these disturbance analyses have identified that Inverter-Based Resources involved did not have sufficient monitoring data to understand the plants' responses. The initiating event, e.g., a normally cleared transmission fault, was not a large-scale system disturbance; however, Inverter-Based Resource's undesirable response due to a system fault resulted in a larger system disturbance. Adequate monitoring data is required to understand Inverter-Based Resource's performance. Most of the Inverter-Based Resources involved in these disturbances did not have and were not required to have adequate disturbance monitoring data. The lack of disturbance monitoring data available from these facilities led to difficulty in adequately assessing the events. Introducing Inverter-Based Resource monitoring requirements to Reliability Standard PRC-002 may create unintended consequences to purpose of Reliability Standard PRC-002 and may lead to industry confusion. Hence, to address needs identified in the Standard Authorization Request (SAR) submitted by the Inverter-Based Resource Performance Task Force (IRPTF), a new standard for monitoring requirements for Inverter-Based Resources is created instead of revising the Reliability Standard PRC-002.

The Generator Owners, as applicable, will have the responsibility for ensuring that adequate data is available for applicable Elements at the applicable Inverter-Based Resources. This standard requires that sequence of events recording (SER), fault recording (FR), and dynamic disturbance recording (DDR) data is available from the applicable Inverter-Based Resources.

## **Rationale for Applicability Section**

### **Functional Entities**

The functional entity that is responsible for implementing disturbance monitoring equipment and collecting recording data is Generator Owner.

### **Applicable Facilities**

The BES Inverter-Based Resources and Non-BES Inverter-Based Resources that either have or contribute to an aggregate nameplate capacity of greater than or equal to 20 MVA, connected through a system designed primarily for delivering such capacity to a common point of connection at a voltage greater than or equal to 60 kV, are in the scope of this standard.

Order No. 901 directed NERC to develop Reliability Standards “to require registered IBR generator owners to install disturbance monitoring equipment at their buses and elements, to require registered IBR generator owners to provide disturbance monitoring data to Bulk-Power System planners and operators for analyzing disturbances on the Bulk-Power System, and to require Bulk-Power System planners and operators to validate registered IBR models using disturbance monitoring data from installed registered IBR generator owners’ disturbance monitoring equipment.” Order No. 901 at P 85. FERC continued, “We further agree with the findings in NERC reports (e.g., a lack of high-speed data captured at the IBR or plant-level controller and low-resolution time stamping of inverter sequence of event recorder information has hindered event analysis) and direct NERC through its standard development process to address these findings.”

In distinguishing among the different types of IBRs and their registration status that must be covered by the standards, FERC stated: “Where necessary to describe our directives, however, we differentiate between IBRs registered with NERC (or which will be registered pursuant to the Commission’s directives in Registration of Inverter-based Resources, 181 FERC ¶ 61,124 (2022) (IBR Registration Order)) and therefore subject to the Reliability Standards (i.e., registered IBR), IBRs connected directly to the Bulk-Power System but not registered with NERC and therefore not subject to the Reliability Standards (i.e., unregistered IBRs), and IBRs connected to the distribution system that in the aggregate have a material impact on the Bulk Power System (i.e., IBR-DER).” Order No. 901 at n. 14.

In proposed PRC-028-1, the standard drafting team includes both categories of generation that would be registered under proposed changes to NERC Rules of Procedure consistent with Order No. 901. In February 2024, the NERC Board of Trustees approved revisions to the Rules of Procedure to expand the Generator Owners and Generator Operators registered with NERC for compliance purposes. In addition to owners and operators of generating Facilities, NERC will register owners and operators of sub-BES IBRs meeting the following criteria: non-BES inverter based generating resources that either have or contribute to an aggregate nameplate capacity of greater than or equal to 20 MVA, connected through a system designed

primarily for delivering such capacity to a common point of connection at a voltage greater than or equal to 60 kV. On June 27, 2024, FERC issued an order approving NERC’s proposed revisions to its Rules of Procedure, subject to NERC submitting a compliance filing, under section 215 of the Federal Power Act.

The following Elements associated with Inverter-Based Resources noted above are in the scope of this standard:

- Circuit breaker(s) (or interrupting devices)
- Main power transformer(s)
- Collector bus
- Shunt static or dynamic reactive device(s)<sup>1</sup>, including any filter banks,
- AC-DC and DC-AC converters, if any, in case of VSC HVDC line with a dedicated connection to Inverter-Based Resource

The following examples are provided to clarify applicability of the PRC-028 standard.

**Example 1: Applicability of PRC-028**

Figure 1 shows a typical single line diagram of an Inverter-Based Resource. The Inverter-Based Resource is connected to the transmission system via a short tie-line. This Inverter-Based Resource is equipped with a dynamic reactive device (e.g., synchronous condenser, static VAR compensator etc.) connected to the collector bus.

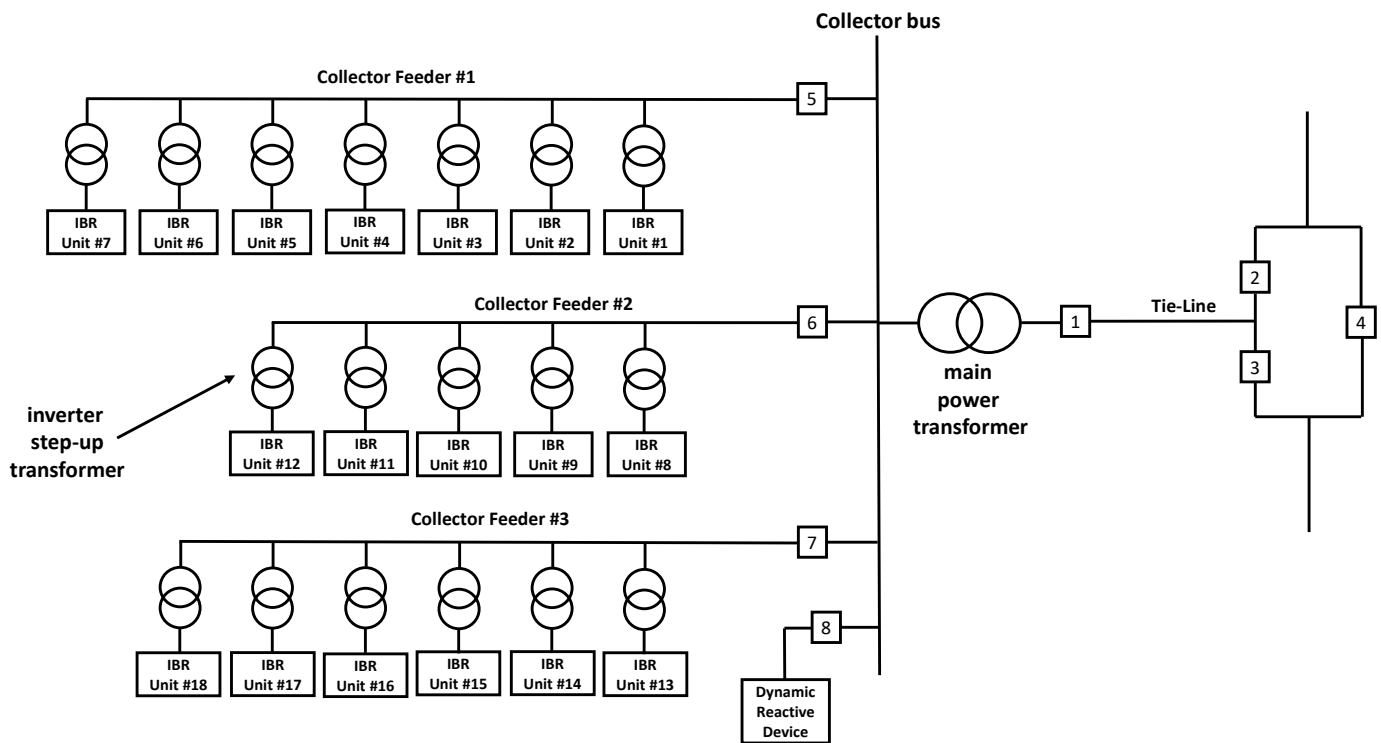

Figure 1: Typical Inverter-Based Resource Single Line Diagram

<sup>1</sup> Synchronous condensers when installed within the Inverter-Based Resource are considered shunt dynamic reactive devices.

**SER Data:** The SER data is required for circuit breakers 1, 5, 6, 7, and 8. Circuit breaker 1 is associated with the main power transformer. Circuit breakers 5, 6, 7, and 8 are associated with the collector bus. The SER data from all IBR units is required.

**FR Data:** The FR data is required from high side terminals of the main power transformer. In this example, the Inverter-Based Resource consists of only one main power transformer. If the Inverter-Based Resource consists of more than one main power transformer, then FR data for each main power transformer is required. As the Inverter-Based Resource is equipped with the dynamic reactive device, the FR data for it is also required. The FR data from collector feeder circuit breakers 5, 6, and 7 is also required.

**DDR Data:** The DDR data is required from high side terminals of the main power transformer. If the Inverter-Based Resource consists of more than one main power transformer, then DDR data for each main power transformer is required.

**Example 2: Applicability of PRC-028 (Facility with two collector buses and main power transformers)**

Figure 2 shows a single line diagram of an Inverter-Based Resource with two collector buses and main power transformers. The Inverter-Based Resource is connected to the transmission system via a short tie-line. The collector feeders #1 and #2 are connected to collector bus #1. The collector feeders #3 and #4 are connected to collector bus #2.

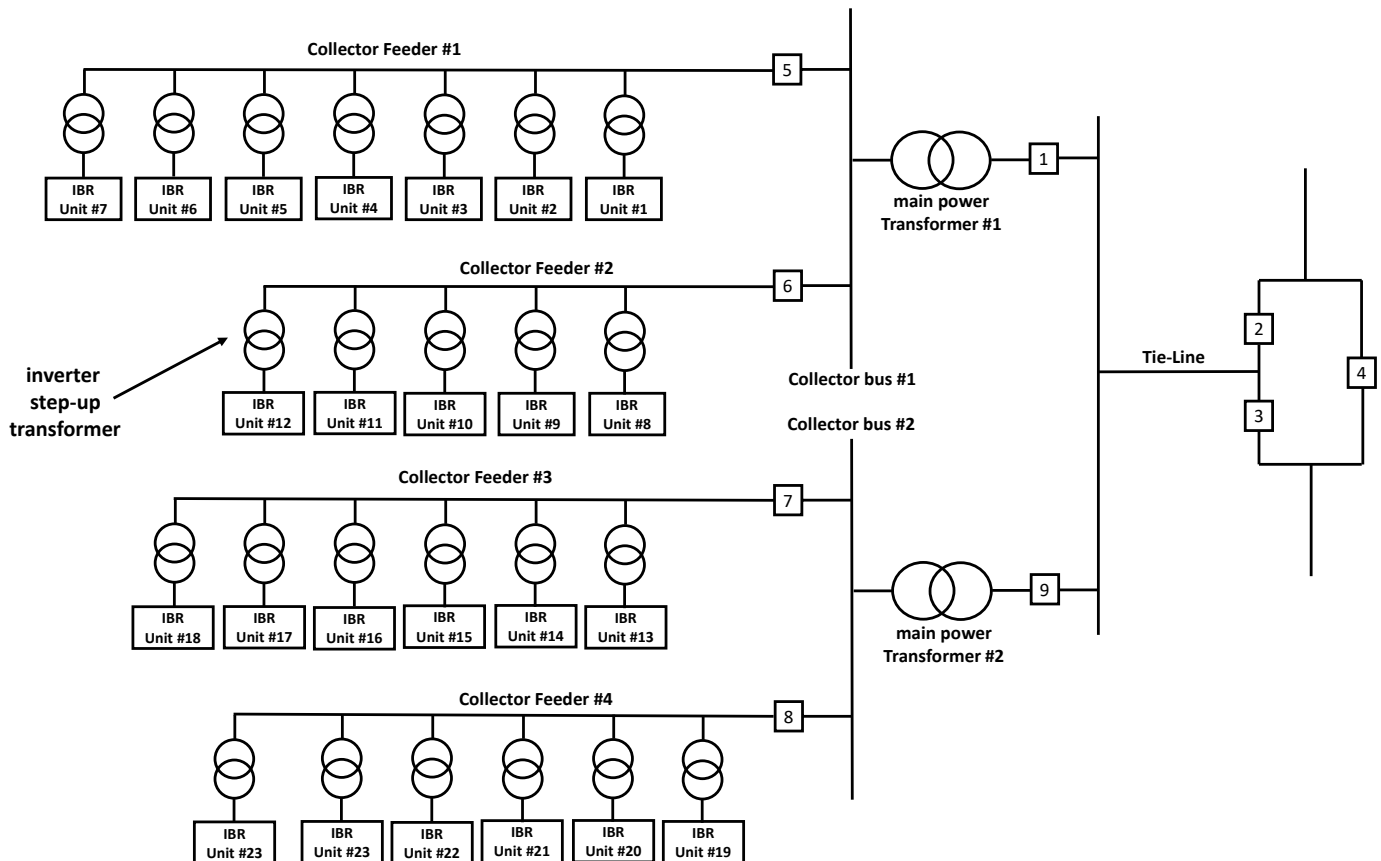

Figure 2: Typical Inverter-Based Resource with two collector buses and main power transformers

**SER Data:** The SER data is required for circuit breakers 1, 5, 6, 7, 8, and 9. Circuit breakers 1 and 9 are associated with main power transformers. Circuit breakers 5, 6, 7, and 8 are associated with collector buses #1 and #2. The SER data from all IBR units is required.

**FR Data:** The FR data is required from high side terminals of both main power transformers. The FR data from collector feeder circuit breakers 5, 6, 7, and 8 is also required.

**DDR Data:** The DDR data is required from high side terminals of both main power transformers.

**Example 3: Applicability of PRC-028 (VSC HVDC system with a dedicated connection to Inverter-Based Resources)**

Figure 3 shows an example of dedicated VSC HVDC system connecting the Inverter-Based Resource<sup>2</sup>. Transformers on both sides of the HVDC system are considered main power transformer.

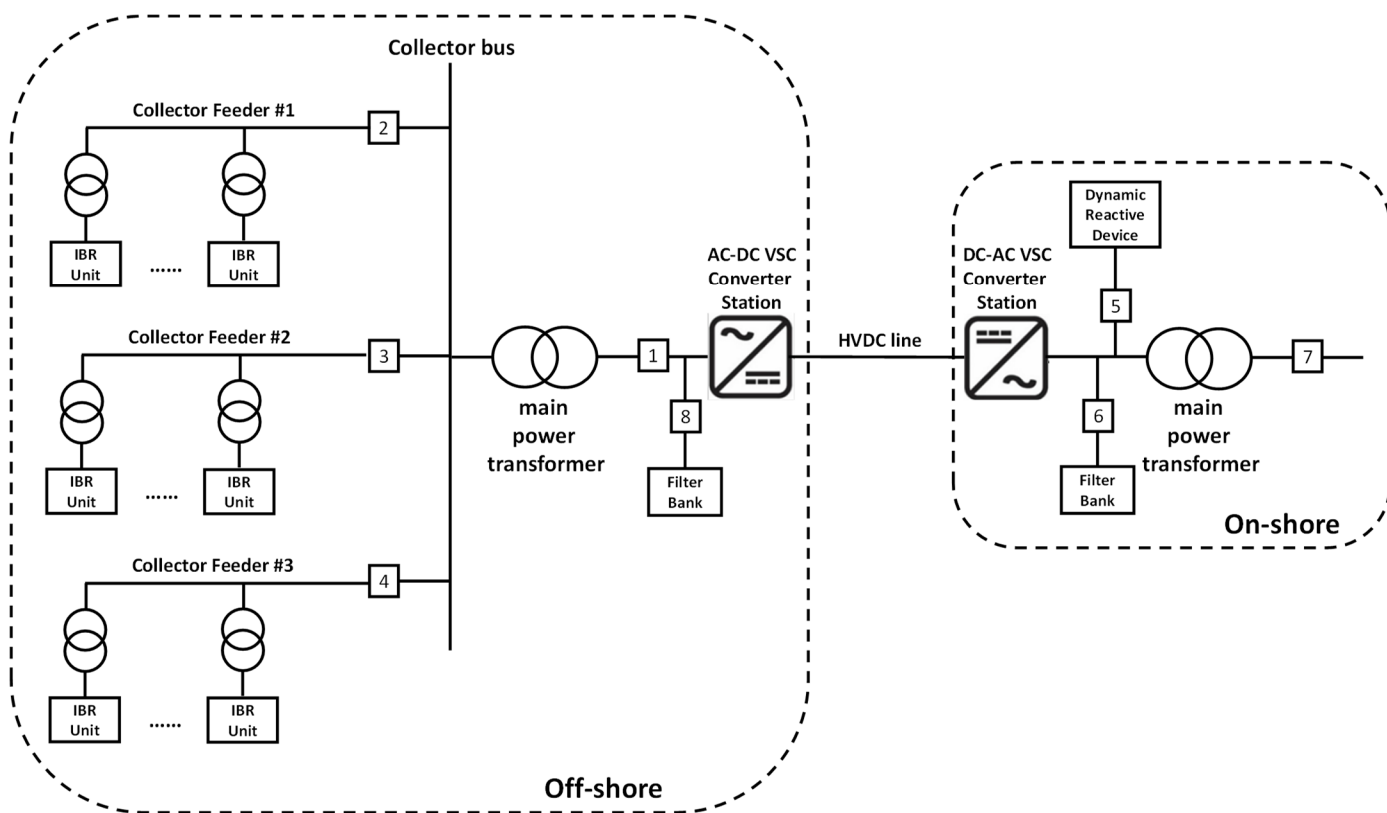

Figure 3: Typical Inverter-Based Resource connected via dedicated VSC HVDC

<sup>2</sup> Refer to Technical Rationale Project 2020-06 Verification of Models and Data for Generators Inverter-based Resource Definition available at: [https://www.nerc.com/pa/Stand/Project\\_2020\\_06\\_Verifications\\_of\\_Models\\_and\\_Data\\_f/2020-06\\_IBR\\_Definition\\_Technical\\_Rationale\\_Clean\\_07122024.pdf](https://www.nerc.com/pa/Stand/Project_2020_06_Verifications_of_Models_and_Data_f/2020-06_IBR_Definition_Technical_Rationale_Clean_07122024.pdf).

**SER Data:** The SER data is required for circuit breakers 1, 2, 3, 4, 5, 6, 7, and 8. Circuit breakers 1 and 7 are associated with main power transformers. Circuit breakers 2, 3, and 4 are associated with the collector bus. Circuit breakers 6 and 8 are associated with filter banks and circuit breaker 5 is associated with shunt dynamic reactive device. The SER data from all IBR units is required.

**FR Data:** The FR data is required from high side terminals of both main power transformers. The FR data from collector feeder circuit breakers 2, 3, and 4 is also required.

**DDR Data:** The DDR data is required from high side terminals of both main power transformers.

**Example 4: Applicability of PRC-002 versus PRC-028**

Figure 4 shows an example of Inverter-Based Resource interconnection to the transmission system via Line 34. The BES bus in substation Wu is the identified BES bus per methodology in Attachment 1 of the Reliability Standard PRC-002. The SER and FR data requirements for the identified BES bus are per the requirements in the Reliability Standard PRC-002. The Reliability Standard PRC-028 is applicable to the Inverter-Based Resource.

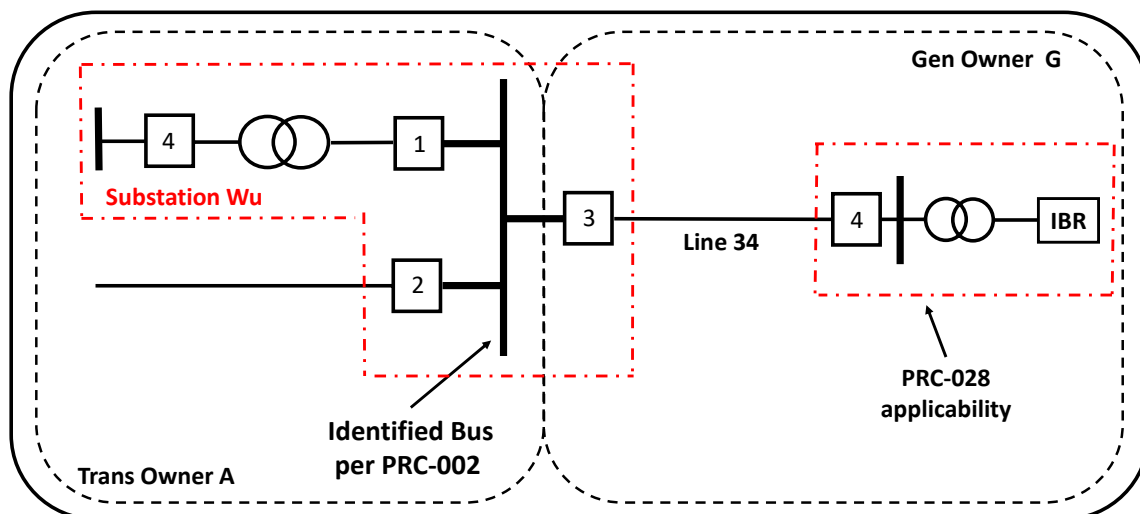

Figure 4: Inverter-Based Resource Interconnection – Applicability of PRC-002 versus PRC-028

**Rationale for Requirement R1**

The standard is required to capture SER data from circuit breakers within the Inverter-Based Resource associated with:

- Main power transformer(s)
- Collector bus(es), including collector feeder breakers
- Shunt static or dynamic reactive device(s), including any filter banks
- AC-DC and DC-AC converters, if any, in case of VSC HVDC system with a dedicated connection to Inverter-Based Resources.

The standard also requires capturing SER data from all IBR units. However, it is recognized that for IBR units in commercial operation before the effective date of this standard, IBR units may not be capable to capture SER data. If IBR unit is in commercial operation before the effective date of this standard and not capable to capture SER data then SER data is not required. The SER data required from IBR units are as follows: all fault codes and alarms, high and low voltage/frequency ride-through mode status.

Change of state of circuit breaker position and IBR unit SER data, time stamped according to Requirement R7 to a time synchronized clock, provides the basis for assembling the detailed sequence of events timeline of Inverter-Based Resource's response during a power System disturbance. Analyses of system disturbances often begin by evaluation of SERs to help determine the initiating event(s) and follow the disturbance propagation. Recording of breaker operations helps determine the interruption of flows during the disturbances.

### **Rationale for Requirement R2**

The intent is to capture sufficient FR data for Elements at each Inverter-Based Resource to analyze the overall response of the Inverter-Based Resource to a system disturbance. Analyses of disturbances involving widespread reduction of power output from Inverter-Based Resources in recent years has shown that expansion of monitoring at Inverter-Based Resource sites is necessary. The required electrical quantities may either be directly measured or determinable if sufficient FR data is captured (e.g., residual or neutral current if the phase currents are directly measured).

The FR data captured from IBR units helps in understanding individual IBR unit's response during system disturbances. However, in lieu of requiring FR data from IBR units, standard requires FR data from collector feeder breakers. The FR data captured from collector feeder breakers provides information about collective response of IBR units on a given collector feeder during system disturbances.

The plant level FR measurements, i.e., measured on high-side terminals of the main power transformer, specified in Requirement R2, Part 2.1 provide data at the Inverter-Based Resource interconnection to the bulk power system. To cover all possible fault types, phase-to-neutral voltage recording for each phase is required to be determinable. Each phase current and residual current are required to distinguish between phase faults and ground faults. This data also facilitates determination of the fault location and cause of relay operation. The measurements of active and reactive power provide data on the overall generating facility's response to the system disturbance.

In some cases, the dynamic reactive device is used within the Inverter-Based Resource and often connected to medium voltage collector bus. Regardless of where dynamic reactive device is connected, the output of it during system disturbances is important to understand overall performance of the plant during a disturbance. The measured or determined electrical quantities for dynamic reactive device are same as those specified to be measured/determined from high-side of main power transformer.

### Recording of Electrical Quantities

For effective fault analysis, it is necessary to know values of all phase and neutral currents and all phase-to-neutral voltages. Based on such FR data, it is possible to determine all fault types. FR data also augments

SERs in evaluating circuit breaker operation. FR also shows generator output response to a system disturbance.

### Current Recordings

The required electrical quantities are normally directly measured. Certain quantities can be derived if sufficient data is measured, for example residual or neutral currents. Since a Transmission System is generally well balanced, with phase currents having essentially similar magnitudes and phase angle differences of 120 degrees, during normal conditions there is negligible neutral (residual) current. In case of a ground fault, the resulting phase current imbalance produces residual current that can be either measured or calculated.

Neutral current, also known as ground or residual current  $I_r$ , is calculated as a sum of vectors of three phase currents:

$$I_r = 3 \cdot I_0 = I_A + I_B + I_C$$

$I_0$  - Zero-sequence current

$I_A, I_B, I_C$  - Phase current (vectors)

### Voltage Recordings

Voltages are to be recorded or accurately determined at applicable Elements as outlined in Requirement R2.

### **Rationale for Requirement R3**

Time stamped pre- and post-trigger FR data aid in the analysis of power system operations and determination if operations were as intended.

The “Odessa Disturbance” report from September 2021 recommended high resolution oscillography data at the point of interconnection. The minimum recording rate of 64 samples per cycle is specified recognizing state-of-the-art for DME including storage any storage capability limitations and provides sufficient data to recreate accurate response of the Inverter-Based Resource to system disturbances.

Pre- and post-trigger fault data along with the SER data, all time stamped to a common clock, aid in the analysis of Protection System operations after a fault to determine if a Protection System operated as designed. Additionally, Inverter-Based Resources employ fast acting control systems (with built in protection functions) dictating Inverter-Based Resource’s response to system disturbance. Generally speaking, BES faults persist for a very short time period, approximately 1 to 30 cycles. To capture the full response of Inverter-Based Resource spread over a large geographic area, a 2 second total minimum record length synchronized to a common clock is necessary for FR data. Multiple records allow for legacy microprocessor relays which, when time synchronized to a common clock, can provide adequate fault data but are not capable of providing fault data in a single record with 120 continuous cycles total.

FR triggers can be set so that when the monitored value on the recording device goes above or below the trigger value, data is recorded. Requirement R3, Part 3.1.3.1 specifies a neutral (residual) overcurrent



trigger for ground faults. Requirement R3, sub-Part 3.1.3.2 specifies a phase overvoltage or undervoltage trigger during voltage ride-through events.

The triggers specified in Requirement R3, Part 3.3 for dynamic reactive device FR data are similar to ones specified in Requirement R3, Part 3.1 for plant level FR data measured or determined on high-side of the main power transformer.

#### **Rationale for Requirement R4**

Large scale system disturbances generally are an evolving sequence of events that occur over an extended period of time, making DDR data essential for event analysis. Data available pre- and post-contingency helps identify the causes and Inverter-Based Resource's response to large scale system disturbances. Therefore, continuous recording and storage are necessary to ensure sufficient data is available for the entire event. The state-of-the-art DDR equipment is capable of continuous recording.

DDR data contains the dynamic response of the Inverter-Based Resource to a system disturbance and is used for analyzing complex power system events. This recording is typically used to capture short-term and long-term disturbances. Since the data of interest is changing over time, DDR data is normally stored in the form of RMS values or phasor values, as opposed to directly sampled data as found in FR data.

DDR is used to measure transient response to system disturbances during a relatively balanced post-fault condition. Therefore, it is sufficient to provide a single phase-to-neutral voltage or positive sequence voltage and current from the same phase or positive sequence for each applicable main power transformer for analysis. It is also sufficient to provide a single frequency for any of the provided voltages since all main power transformers within an Inverter-Based Resource are at the same frequency. Recording of all three phases of voltage/current is not required, although this may be used to compute and record the positive sequence value(s). The electrical quantities for Real Power and Reactive Power on a three-phase basis can be measured/recorded or determined (calculated, derived, etc.).

The data requirements for PRC-028-1 are based on a system configuration assuming all normally closed circuit breakers on a BES bus are closed.

A crucial part of disturbance analysis is understanding the dynamic response of generating resources. Therefore, it is necessary to have DDR on high-side of the main power transformer(s) measuring the specified electrical quantities to adequately capture Inverter-Based Resource's response.

The Requirement R4, Part 4.1 requires either one phase-to-neutral or positive sequence voltage. However, the phase-to-phase voltage recording is acceptable. Since the BES operates under a relatively balanced operating condition and, if needed, phase-to-neutral quantities can be derived from phase-to-phase quantities.

#### **Rationale for Requirement R5**

An input sampling rate of at least 960 samples per second, which corresponds to 16 samples per cycle on the input side of the DDR equipment, ensures adequate accuracy for calculation of recorded measurements

such as complex voltages and frequency. The input sampling rate specified is same as one specified in the Reliability Standard PRC-002.

An output recording rate of electrical quantities of at least 60 times per second refers to the recording rate of the device. Recorded measurements of at least 60 times per second provide adequate recording speed to monitor the Inverter-Based Resource's response during power system disturbances. Since control system associated with Inverter-Based Resources is fast acting, higher frequency recording is necessary to accurately reconstruct events. An output recording rate of 60 times per second provides this higher frequency recording while not greatly increasing data storage requirements.

### **Rationale for Requirement R6**

Time synchronization of disturbance monitoring data is essential for time alignment of large volumes of geographically dispersed records from diverse recording sources. Coordinated Universal Time (UTC) is a recognized time standard that utilizes atomic clocks for generating precision time measurements. All data must be provided in UTC formatted time either with or without the local time offset, expressed as a negative number (the difference between UTC and the local time zone where the measurements are recorded).

Accuracy of time synchronization applies only to the clock used for synchronizing the monitoring equipment. The equipment used to measure the electrical quantities must be time synchronized to  $\pm 1$  millisecond accuracy; however, accuracy of the application of this time stamp and therefore, the accuracy of the data itself is not mandated. This is because of inherent delays associated with measuring the electrical quantities and events such as breaker closing, measurement transport delays, algorithm and measurement calculation techniques, etc.

Ensuring that the monitoring devices internal clocks are within  $\pm 1$  millisecond accuracy will suffice with respect to providing time synchronized data. Accuracy of time synchronization applies only to the clock used for synchronizing the monitoring equipment. Note that the recently published IEEE Std 2800 requires the DME recording plant level data be synchronized to the clock with accuracy of  $\pm 1$  microsecond accuracy; however, the accuracy requirement is set to  $\pm 1$  millisecond to strike a balance between need of accuracy and practical limitations of equipment necessary to achieve the stated accuracy. Recognizing challenges with distributing synchronizing clock signal to all IBR units with the Inverter-Based Resource, the IBR units (for capturing of SER data) are required to have synchronized device clock accuracy within  $\pm 100$  milliseconds of UTC.

The Inverter-Based Resources, which are not affected by inertial time constants, make changes in power production very rapidly. To understand and analyze control decisions during system disturbances and the reasons behind them over dozens of plants requires a high level of accurate time synchronization. The following provide some examples of Inverter-Based Resource's fast response:

- Typical 90% response to a three-phase fault is  $< 40$  ms.
- Central power plant controllers issue updated commands in as little as 40 ms upon detection of change in system conditions.
- Standard closed loop voltage control response can be  $< 200$  ms.

- Instantaneous Inverter protective trip decisions such as AC or DC overvoltage or reverse DC current can be made in less than 10 ms.

### **Rationale for Requirement R7**

Requirement R7, Part 7.1 specifies a minimum time period of 20 calendar days inclusive of the day the data was recorded for which the data is to be retrievable. Data hold requests are usually initiated the same or next day following a major event, however, it takes a longer time to determine which data from which generating facility needs to be retrieved for event analysis. A 20 calendar day time period provides enough time for communication between various Entities regarding the event and need for data retrieval from DME at various generating facilities. The requestor of data has to be aware of 20 calendar day retrievability limit to ensure timely data hold requests. Requiring data retention for a longer period of time is expensive and unnecessary.

With the state-of-the-art equipment, having the data retrievable for the 20 calendar days is realistic and doable. It is important to note that applicable entities should account for any expected delays in retrieving data and this may require devices to have data available for more than 20 days. To clarify the 20 calendar day time frame, let's assume that event occurs on Day 1. If a request for data is made on Day 6, then that data has to be provided to the requestor within 20 calendar days after a request or a granted time extension. However, if a request for the data is made on Day 21, that is outside the 20 calendar days specified in the requirement, and an entity would not be out of compliance if it did not have the data.

This requirement directs the applicable entities, upon requests from the Reliability Coordinator, Regional Entity or NERC, to provide SER, FR and DDR data for generating facilities as per the applicability. To facilitate the analysis of system disturbances, it is important that the data is provided to the requestor within a reasonable time. Providing the data within 15 calendar days (or the granted extension time), subject to Requirement R7, Part 7.2, allows for reasonable time to collect the data and perform any necessary computations or formatting. An entity may request an extension of the 15 calendar days submission requirement. If granted by the requestor, the entity must submit the data within the approved extended time.

Disturbance analysis includes reviewing data recording from many devices and entities. Standardized formatting and naming conventions of these files significantly improve timely analysis. The formatting and naming convention requirements for SER, FR, and DDR are consistent with same requirements in the Reliability Standard PRC-002.

**SER data:** Requirement R7, Part 7.3 specifies a simple ASCII Comma Separated Value (CSV) format according to Attachment 1. It is necessary to establish a standard format as it allows data submitted by one entity or facility to be incorporated with same data provided by other entities or facilities to develop a detailed sequence of events timeline of a power system disturbance.

**FR data:** Requirement R7, Part 7.4 specifies either CSV format with appropriate headers or the IEEE C37.111 Standard for Common Format for Transient Data Exchange (COMTRADE) format for the FR data. The IEEE C37.111 is well established in the industry. Exchanging data in a standard format helps in analysis of a power

system disturbance, especially considering multiple data submission from many sources.

**DDR data:** Requirement R7, Part 7.5 specifies either CSV format with appropriate headers or the IEEE C37.111 Standard for Common Format for Transient Data Exchange (COMTRADE) format for the DDR data. The IEEE C37.111 is well established in the industry. Exchanging data in a standard format helps in analysis of a power system disturbance, especially considering multiple data submission from many sources.

The 2013 revision of the IEEE C37.111 includes an annex describing the application of the COMTRADE standard to synchrophasor data.

Requirement R7, Part 7.6 specifies the IEEE C37.232 Standard for Common Format for Naming Time Sequence Data Files (COMNAME) format for naming the SER, FR, and DDR data files. The lack of a common naming practice seriously hinders the event analysis and investigation process.

### **Rationale for Requirement R8**

The standard requires that Entity restore the recording capability for SER, FR, or DDR data within 90 calendar days of the discovery of a failure. The 90 calendar day time period permitted in this requirement strikes a balance between reasonable time needed to restore capability while ensuring that recording capability is not out of service for an extended duration. If the recording capability cannot be restored within 90 calendar days due to limitations such as budget cycle, service crews, vendors, needed outages, etc., the entity is required to submit a Corrective Action Plan for restoring the recording capability to the Regional Entity and implement it. It is treated as a failure if the recording capability is out of service for maintenance and/or testing for greater than 90 calendar days. An outage of the monitored Element does not constitute a failure of the disturbance monitoring capability.