

NERC

NORTH AMERICAN ELECTRIC
RELIABILITY CORPORATION

Misoperation Information Data Analysis System

Data Reporting Instructions

Effective: January 1, 2024

RELIABILITY | RESILIENCE | SECURITY



3353 Peachtree Road NE
Suite 600, North Tower
Atlanta, GA 30326
404-446-2560 | www.nerc.com

Table of Contents

Revision History.....	iv
Preface	v
Introduction	vi
Who Must Report.....	vi
When does reporting start?	vi
What will be reported?	vi
NERC Rules of Procedure for Section 1600:	vi
Chapter 1: Data Transmittal and Format	1
Transmittal	1
Format	1
Reporting Deadlines	1
Questions and Comments	1
Chapter 2: Identifying Composite Protection Systems	2
What is not included in Composite Protection System?	2
Chapter 3: Composite Protection System Operations	5
Chapter 4: Misoperations	8
Chapter 5: MIDAS Opt-Out Waivers	14
Creating a Waiver	14
If there are no Protection System Operations to Report	14
If there are only Protection System Operations to Report	14
Multi-Region Registered Entity Opt Outs	14
Appendix A: Glossary	15
Appendix B: Systematically Determining Misoperations.....	21
Appendix C: Composite Protection System Operations Examples	23
General Examples.....	23
Line Fault Examples	23
Generator Examples	25
Appendix D: Misoperations Examples	26
General Examples.....	26
Generator Examples	34
Environmental Examples	34
Appendix E: Reporting on Tie-Lines	35
1/N Method (Recommended)	35

Table of Contents

Example for the 1/N Method 35

Appendix F: Reporting as a Multi-Region Registered Entity 36

 Reporting Composite Protection System Operations 36

 Pre-Determined Method 36

 Reporting Misoperations 36

 Definitions 36

Appendix G: Reference Tables 37

Appendix H: Misoperation Characterization Flow Diagram 41

Revision History

Version	Revised Date	Effective Date	Revision Notes
2024	1/2024	1/1/2024	<p>The following fields have been removed as part of a minor Section 1600 revision:</p> <ul style="list-style-type: none"> • TADS Reportable • TADS Elements • GADS Reportable • GADS Elements <p>Removed fields will still exist for Misoperations that occurred before 2024.</p> <p>The following fields have been added as part of a minor Section 1600 revision:</p> <ul style="list-style-type: none"> • Count of Transmission AC & DC Circuits Removed From Service • Count of Transmission Transformers Removed From Service • Count of Conventional Generation Units and Inverter-Based Plants Removed From Service <p>Documentation regarding modified fields has been updated accordingly.</p> <p>Clarification added regarding resubmitting CPSOps counts.</p> <p>Fault Type field has been corrected to be voluntary.</p> <p>Voltages and capacitors added to Differential (Protection System Scheme) definition.</p> <p>Capacitor bank example added.</p>
2022	1/2022	1/1/2022	Approved by MIDASWG 12/14/2021
2019 (Draft)		6/1/2019	
1.0	12/2019	1/1/2020	<p>Approved by MIDASWG: 10/7/2019</p> <p>Performance Analysis Subcommittee: 10/24/2019</p> <p>Planning Committee: 12/11/2019</p>

Preface

Electricity is a key component of the fabric of modern society and the Electric Reliability Organization (ERO) Enterprise serves to strengthen that fabric. The vision for the ERO Enterprise, which is comprised of NERC and the six Regional Entities, is a highly reliable, resilient, and secure North American bulk power system (BPS). Our mission is to assure the effective and efficient reduction of risks to the reliability and security of the grid.

Reliability | Resilience | Security
Because nearly 400 million citizens in North America are counting on us

The North American BPS is made up of six Regional Entities as shown on the map and in the corresponding table below. The multicolored area denotes overlap as some load-serving entities participate in one Regional Entity while associated Transmission Owners/Operators participate in another.



MRO	Midwest Reliability Organization
NPCC	Northeast Power Coordinating Council
RF	ReliabilityFirst
SERC	SERC Reliability Corporation
Texas RE	Texas Reliability Entity
WECC	WECC

Introduction

The Misoperation Information Data Analysis System (MIDAS) Data Reporting Instructions were developed to assist industry personnel in reporting information to NERC's MIDAS Portal application. The instructions detail the procedures, schedule, and format to follow when reporting data. Throughout this document, the term "entity" will be used to refer to the principal organization that is designated to report by the 1600 Data Request.

Who Must Report

Reporting of Composite Protection System Misoperation information is mandatory for all NERC registered Transmission Owners (TOs), Generator Owners (GOs), and Distribution Providers (DPs) within the U.S. Non-U.S. TOs, GOs, and DPs should provide data in accordance with the legislation, laws, regulations, rules, or orders of their Applicable Governmental Authority. Non-U.S. TOs, GOs, and DPs are strongly encouraged to provide the requested data to ensure the completeness of the data collected for analysis. Participating organizations must be prepared to commit the necessary effort to provide timely, accurate, and complete data. The reporting instructions detail the data elements identified by the industry and ERO as being vital to the understanding and interpretation of protection system performance.

When does reporting start?

- Newly Registered Entity– Newly registered GOs, TOs, and DPs are expected to begin reporting when NERC registration becomes effective.
- Newly Commissioned Equipment/Facilities – Newly commissioned equipment and facilities should be reported on once released for service for transmission equipment and on their commercial date for generation.
- Existing Equipment Determined to be Bulk Electric System (BES) – If equipment is determined to be BES after having already been installed and placed in service reporting should begin upon determination.

Note:

Entities are expected to backfill data if there are any delays due to administration issues during the registration process, such as MIDAS Portal account setup.

What will be reported?

1. BES Composite Protection System Operation Summary Data – Required quarterly when reportable BES Composite Protection System Operations occur, aggregated by facility voltage.
2. BES Misoperation Data – Required quarterly when reportable BES Misoperations occur, as detailed by the Section 1600 data request. This includes BES Composite Protection Systems for all BES registered Elements, including those in temporary non-BES configurations.
3. Opt-Out Waiver – Required quarterly in cases where no Protection System Operations or Misoperations have occurred.

NERC Rules of Procedure for Section 1600:

"The provisions of Section 1600 shall not apply to requirements contained in any Reliability Standard to provide data or information; the requirements in the Reliability Standards govern. The provisions of Section 1600 shall also not apply to data or information requested in connection with a compliance or enforcement action under Section 215 of the Federal Power Act, Section 400 of these Rules of Procedure, or any procedures adopted pursuant to those authorities, in which case the Rules of Procedure applicable to the production of data or information for compliance and enforcement actions shall apply".

Chapter 1: Data Transmittal and Format

Transmittal

There are three different types of data files to submit in MIDAS:

1. Composite Protection System Operation Summary
2. Composite Protection Misoperation Entry Form
3. Opt-Out Waiver

Composite Protection System Operation Summary and Misoperation data are required to be submitted quarterly, within 60 days of the end of every calendar quarter via the MIDAS Portal reporting application. Data can either be submitted using manual entry functionality available within the MIDAS portal or in bulk using the MIDAS Reporting Template available on the Protection System Misoperations¹ page on the NERC website.

Format

Data shall be submitted quarterly to NERC through the MIDAS reporting application within 60 days after the end of each calendar quarter. Reporting deadlines are posted on the Protection System Misoperations page on the NERC website.

File names for good file management would include the entity name and reporting period as part of the file name to easily differentiate between records. Misoperations for entities registered under the same NERC Compliance Registry (NCR) number in multiple Regions can be reported within the same bulk submission file. NERC will be looking for specific tab labels for each report type.

Reporting Deadlines

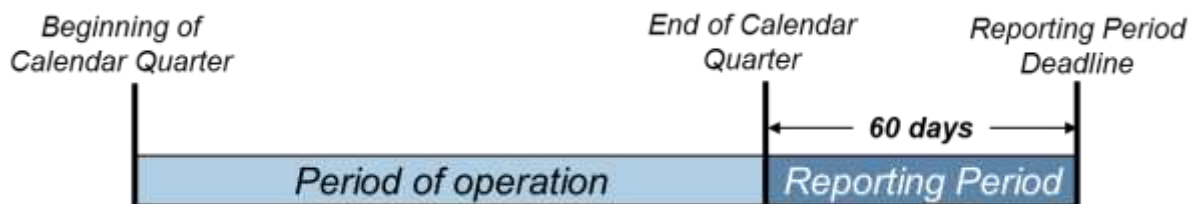

Figure 1.1: Reporting Timeline

An entity is required to notify their Regional Entity contact when they are unable to complete their data reports by the reporting deadline. The Regional Entity contacts are available on the Protection System Misoperations page on the NERC website.

Questions and Comments

All questions regarding data transmittals and reporting procedures should be directed to MIDAS@nerc.net.

¹ <https://www.nerc.com/pa/RAPA/Pages/Misoperations.aspx>

Chapter 2: Identifying Composite Protection Systems

The descriptions below are taken from the [NERC Glossary of Terms](#), if discrepancies exist the Glossary of Terms should be deferred to.

A Composite Protection System is the total complement of Protection System(s) that function collectively to protect an element. Due to the extensive variation from system to system and ever-changing nature of technology the protection schemes listed below are not an exhaustive list, just protection schemes whose inclusion commonly comes into question.

Table 2.1 and **Table 2.2** list Protection Systems and specific protection schemes that are considered as part of a Composite Protection System.

Table 2.1: Protection Systems
Protective relays which respond to electrical quantities
Communications systems necessary for correct operation of protective functions
Voltage and current sensing devices providing inputs to protective relays
Station dc supply associated with protective functions (including station batteries, battery chargers, and non-battery based dc supply)
Control circuitry associated with protective functions through the trip coil(s) of the circuit breakers or other interrupting devices

Table 2.2: Protection Schemes
Switch on to fault protection scheme
Re-Trip scheme
Communication aided tripping scheme
Transfer trip scheme, if in place to protect a BES element(s) or both BES and non-BES elements. Transfer trip in place to protect both BES and non-BES elements should only have its operations and Misoperations reported on if they occur in order to protect the BES element(s).
Breaker failure scheme, should be considered part of the circuit breaker's Composite Protection System, not the transmission line's Composite Protection System. Breaker failure schemes should have their Protection System operations and Misoperations reported even if they do not respond to voltage or current (i.e. breaker failure schemes that only use auxiliary status contacts and timers).

What is not included in Composite Protection System?

Any relays that do not respond to electrical quantities do not qualify as reportable Protection Systems within MIDAS. Due to the extensive variation from system to system and ever-changing nature of technology the components listed and pictured below are not an exhaustive list, just components whose inclusion commonly comes into question. The following functions and components should not be included when considering a Composite Protection System. (See [Table 2.3](#))

Table 2.3: Functions and components not included in a Composite Protection System
Backup protection provided by a different Element's Protection System(s)
Remedial Action Schemes (RAS), previously known as Special Protection System (SPS)

Table 2.3: Functions and components not included in a Composite Protection System

Control functions within protective relays
Control functions implemented in Supervisory Control and Data Acquisition (SCADA) systems
Reclosing relays
Sudden pressure relays
Breaker mechanisms
Generator controls
Excitation controls
Turbine/Boiler controls
High-voltage dc (HVdc) transmission controls
Devices measuring oil levels, gas pressures, and temperatures
Automatic Voltage Regulator (AVR), while the AVR is considered to be a control function this does not necessarily mean that everything else located in the apparatus is a control function.
Remote terminal units (RTU) control functions,
Flexible ac transmission systems (FACTS) controls such as static VAR compensators (SVC) or static synchronous compensators (STATCOM).
Any components that do not respond to electrical quantities
Control circuitry associated with any components or functions listed above
Pole discrepancy as a control function

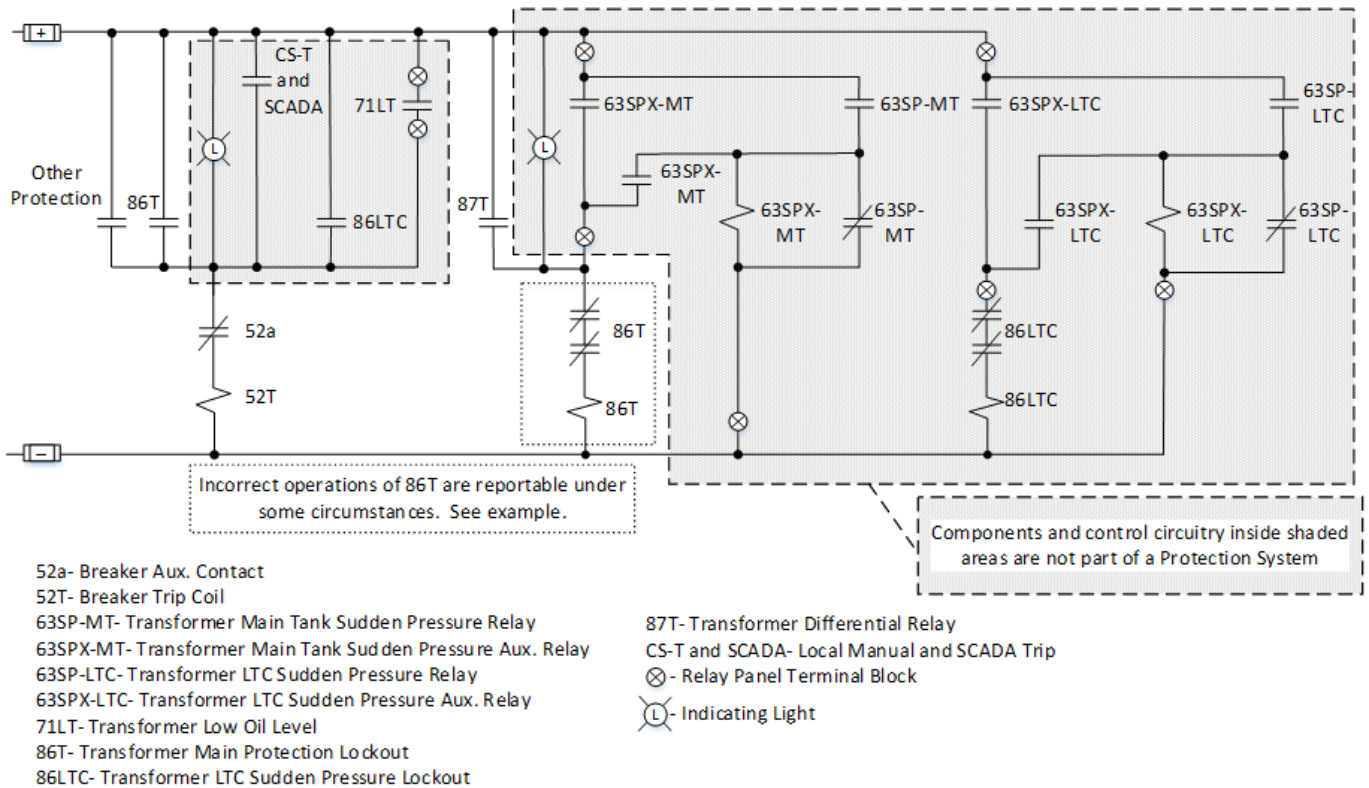

Figure 2.1: Component Inclusion and Exclusion Diagram

Device Inclusion/Exclusion Examples

Devices that perform control functions and devices that do not respond to electrical quantities, such as devices measuring oil level, gas pressure, and temperature, and associated auxiliary relays and dc circuits, are not included in a Composite Protection System. See [Figure 2.1](#) for example:

1. An unnecessary trip caused by operation of 86T in response to an incorrect operation of 87T or malfunction of 86T itself is a reportable Misoperation.
2. A failure to trip caused by failure of 86T to operate in response to 87T is a reportable Misoperation.
3. A failure to trip caused by failure of 52T to operate in response to an 87T-initiated operation of 86T or in response to other protection is a reportable Misoperation.
4. An unnecessary trip caused by operation of 86T or 52T in response to malfunctions in 63SP-MT, 63SP-LTC, 86LTC, manual/SCADA trip, 71LT, or auxiliary relays or wiring associated with these devices is not a reportable Misoperation.
5. A failure to trip caused by failure of 86T or 52T to operate in response to 63SP-MT, 63SP-LTC, 86LTC, manual/SCADA trip, or 71LT is not a reportable Misoperation.
6. An unnecessary trip caused by failure of indicating or monitoring lights or other such devices is not a reportable Misoperation, as these devices perform control functions.

Chapter 3: Composite Protection System Operations

The following encompass the definition for a Composite Protection System Operation (CPSOP):

- The correct operation of a Composite Protection System associated with isolating a faulted system Element.
- The correct operation of a Composite Protection System associated with isolating equipment for non-Fault conditions such as power swings, over excitation, or loss of field (**excluding** control functions performed by a protective relay).
- The unintended operation of a portion of the Composite Protection System for a Fault outside the zone is designed to protect.
- The unintended operation of a portion of the Composite Protection System for a non-Fault condition.
- Any failure of a Composite Protection System to operate for its intended function such as clearing a Fault within the zone it is designed to protect.

Table 3.1: Key Concepts for Composite Protection System Operations

Concept	Description
Inclusion of Operations	A clear indication that an operation was a result of a Composite Protection System should be determined prior to reporting the operation, except as excluded within this table.
Multiple Independent Correct Operations	All correct operations, outside of the reclosing (automatic or manual) sequence, should be reported. Unlike Misoperations, this is inclusive of multiple operations occurring within a 24-hour period.
Inclusion of Misoperations	The Composite Protection System Operations count reported is inclusive of all Composite Protective System Operations, not just correct Composite Protection System Operations. This means that every reported Misoperation will have at least one associated Composite Protection System Operation.
Non-Reportable Operations	If an operation occurs in a situation that would exclude it from being a Misoperation, such as a unit tripping before synchronizing to the system or after disconnecting from the system, the operation would not be reported. This follows the general philosophy that if an incorrect operation would not be a reportable Misoperation, it should not be included as an operation.
Reclosing	Multiple operations of a Composite Protection System due to a sequence of automatic or manual reclosing and tripping should be counted as a single operation.
Control System Operations	Operations that are initiated by control systems (not by Protection Systems), such as those listed in Chapter 2, are not reported as operations of a Composite Protection System.
Operations during Maintenance or Testing	Operations caused by personnel that occur during maintenance, testing, inspection, construction or commissioning should not be reported. This also applies to personnel accidentally operating other equipment during their testing. The maintenance/testing is considered ongoing until the equipment is released for service, so an operation on energization as part of the testing is not reportable. This follows

Table 3.1: Key Concepts for Composite Protection System Operations

Concept	Description
	the general philosophy that if an incorrect operation would not be a reportable Misoperation, it should not be included as an operation.
Backup Relay Systems on the Same Equipment	If a Composite Protection System on the same equipment consists of a primary and local backup relay and the primary relay fails to operate to trip the interrupting device but the local backup relay operates and successfully causes the trip, it is considered a correct CPSOP.
Voltage Class	<p>If the Element is a transformer, the operation should be classified according to the high-side voltage.</p> <p>If the Element is a generator, the operation should be classified according to the GSU transformer high-side voltage.</p> <p>If the Element is a dispersed generation source, such as wind or solar generation, it should be reported based on the voltage at the common point of connection as described in Chapter I4 of the Bulk Electric System Definition Reference Document.</p> <p>If the Element is a reactive device connected to the tertiary of a transformer:</p> <ul style="list-style-type: none"> The tertiary voltage class shall be reported if the tertiary breaker opens, de-energizing only the reactive device. The transformer high-side voltage shall be reported if the transformer breaker opens, de-energizing the transformer.

Table 3.2: Composite Protection System Operation Field Descriptions

Field Name	Description	Mandatory or Voluntary
Data Submission Year	The calendar year for which the operation data is reported.	Mandatory
Data Submission Quarter	The calendar quarter for which the operation data is reported.	Mandatory
Regional Entity Name	The entity's RE. If the entity is registered in multiple REs, the primary RE should be selected. It should be noted that this field should align with the selection made when submitting the file.	Mandatory
NERC ID	The entity's NERC compliance registry (NCR) number. This should include the three letters "NCR" and any preceding or following 0's.	Mandatory
Voltage Class	The system voltage of the protected BES Element. If exact voltage is not	Mandatory

Table 3.2: Composite Protection System Operation Field Descriptions

Field Name	Description	Mandatory or Voluntary
	<p>an available option select closest available option.</p> <p>Use Table G.5 to identify the correct voltage class.</p>	
Total CPSOPs [Composite Protection System Operations] Occurred in ([REGION])	<p>The count of composite protection system operations and the Regions in which they occurred.</p> <p>Note; resubmitting a CPSOPs record will replace existing values, not add to them.</p>	Mandatory

Chapter 4: Misoperations

The definition of the term Misoperation can be found in the [NERC Glossary of Terms](#).

All Misoperations due to the same equipment and cause within a 24-hour period are to be recorded as one Misoperation and one CPSOP.

Table 4.1: Key Concepts for Composite Protection Systems Misoperations

Concept	Description
Multiple Misoperations on a Single Element	<p>If multiple Misoperations occur on a single Element's Composite Protection System during the same event then it should be reported as a single Misoperation, as the Misoperations occurred within the same Composite Protection System. The Misoperation would also be counted as a single CPSOP, in addition to any other Composite Protection Systems that operated as expected to clear the fault. The field should be populated based upon the most critical Misoperation.</p> <p>Any additional Misoperations beyond the most critical should be detailed as part of the event description.</p>
Non-Interrupting Misoperations	Misoperations of BES Composite Protection Systems that trip a BES breaker but do not interrupt BES paths or service are still considered reportable. For example BES breakers, as part of a ring bus, tripping but not interrupting service.
Breaker Trip Coil Failure	A breaker trip coil is considered to be part of the Composite Protection System and should be reported if it causes a Misoperation. Investigation should be made to determine if a mechanical problem (i.e. stuck breaker) is the cause of the trip coil failure; if so it is not a Misoperation. If a defective trip coil is found during maintenance, testing, or through control operations nothing should be reported.
Breaker Mechanism Malfunction	Breaker mechanism malfunction is considered a mechanical failure, not an electrical failure, and should not be reported (note that a mechanical failure can cause a breaker trip coil failure, leading to the incorrect conclusion that a Protection System Misoperation occurred but is really a mechanical failure)
Detected Relay Settings Errors	In cases where a relay settings error is detected without a Misoperation having occurred, nothing should be reported.
Misoperations on De-Energized Elements	<p>In cases where a breaker trips when the protected Element is already de-energized and no in-service BES interrupting devices tripped, nothing should be reported.</p> <p>In cases where the Composite Protection System on a de-energized Element trips and causes the operation of an in-service BES interrupting device, this is a reportable Misoperation, unless otherwise excluded.</p>
UFLS/UVLS	Underfrequency load shedding (UFLS) and undervoltage load shedding (UVLS) system(s) that are intended to trip one or more BES elements should be reported if a system fails to shed load when expected or if a system sheds load inadvertently.
Reverse Power Relays	An entity intentionally uses reverse power relays during normal unit shutdown. If the operation of these relays is part of a controlled shutdown, no operations should be reported to MIDAS.

Table 4.1: Key Concepts for Composite Protection Systems Misoperations

Concept	Description
FACTS Devices	Failure of a FACTS device Composite Protection System to operate as intended for protection purposes should be reported as a misoperation.
Environmental Issues	If a Composite Protection System misoperates due to environmental issues such as induced vibration (excluding onsite personnel), excessive temperature, or water intrusion it should be reported as a Misoperation. These would generally fall under the “Other/Explainable” cause.
Voltage Class	<p>If the Element is a transformer, the operation should be classified according to the high-side voltage.</p> <p>If the Element is a generator, the operation should be classified according to the GSU transformer high-side voltage.</p> <p>If the Element is a dispersed generation source, such as wind or solar generation, it should be reported based on the voltage at the common point of connection as described in Chapter I4 of the Bulk Electric System Definition Reference Document.</p> <p>If the Element is a reactive device connected to the tertiary of a transformer:</p> <ul style="list-style-type: none"> • The tertiary voltage class shall be reported if the tertiary breaker opens, de-energizing only the reactive device. • The transformer high-side voltage shall be reported if the transformer breaker opens, de-energizing the transformer.
Control Functions	Operations that are initiated by control functions, such as those associated with generator controls, turbine/boiler controls, SVC controls, FACTS controls, HVdc transmission system controls, or other facility control functions are not Misoperations.
Failure to Automatically Reclose	Failure to automatically reclose after a fault is not considered a reportable Misoperation.

Table 4.2: Misoperation Field Descriptions

Field Name	Description	Mandatory/ Voluntary/Calculated
Misoperation ID	A unique Misoperation identifier. Automatically concatenated	Calculated
Region	The Region in which the Misoperation occurred. Entities reporting for multiple Regions under the same registration (NCR) can submit for all Regions within the same submittal. The selected Region should be based on the geographical location in which the Misoperation occurred. Use Table G.2 to select the appropriate Region.	Mandatory
Entity	The entity’s NCR number. Ex: NCR99999	Mandatory
Jurisdiction	The country in which the Misoperation occurred. Use Table G.3 to select appropriate jurisdiction.	Mandatory

Table 4.2: Misoperation Field Descriptions

Field Name	Description	Mandatory/ Voluntary/Calculated
Misoperation Date	The date of the Misoperation (MM/DD/YYYY)	Mandatory
Misoperation Time	The time of the Misoperation (24hr format HH:MM:SS) based on the time zone used to record the Misoperation.	Mandatory
Misoperation Time Seconds	The “seconds” portion of the time at which the Misoperation occurred. This field is only separate for entries made through the MIDAS Portal interface.	Mandatory, MIDAS Portal interface submissions only
Time Zone	The time zone in which the Misoperation occurred. Use Table G.1 to select appropriate time zone	Mandatory
Facility Name	The name of the facility (substation or generating station) where the Misoperation occurred.	Mandatory
Equipment Name	The name of the equipment protected by the Composite Protection System that misoperated.	Mandatory
Equipment Type	The type of equipment being protected. Use Table G.4 to select appropriate equipment type	Mandatory
Facility Voltage	The system voltage of the protected BES element. If exact voltage is not an available option select closest available option. Use Table G.5 to select appropriate facility voltage	Mandatory
Equipment Removed	The names of the equipment becoming permanently or temporarily unavailable due to the Misoperation Equipment refers only to circuits, transformers, buses, but not breakers UNLESS the breaker is the only Element. Breakers should be used only if a single breaker tripped and did not disconnect any Element at one of its terminals (one breaker in a multiple breaker terminal, bus tie breaker, etc.).	Mandatory
Fault Type	The type of fault that occurred. Use Table G.9 to identify appropriate fault type.	Voluntary
Event Description	A brief description of the event including: <ol style="list-style-type: none"> 1. Initiating event: include a description of any internal or external fault causes, any abnormal system conditions which may have contributed to the Misoperation, or state that the Misoperation occurred under normal operating conditions. 2. Facilities involved on which Protection Systems operated correctly and/or incorrectly concurrent with the Misoperation. 3. Component(s) of the Composite Protection System(s) that failed and/or did not function correctly. 4. Detailed description of root causes. 	Mandatory
Restoration Method	The restoration method. Use Table G.10 to identify appropriate restoration method	Voluntary
Category	The category of the Misoperation.	Mandatory

Table 4.2: Misoperation Field Descriptions

Field Name	Description	Mandatory/ Voluntary/Calculated
	Use Table G.6 to identify appropriate category	
Cause	The primary cause of the Misoperation. Use Table G.7 to identify appropriate cause of the Misoperation	Mandatory
Count of Transmission AC & DC Circuits Removed From Service	The number of transmission AC and/or DC circuits removed from service as a result of the Misoperation. A single transmission AC circuit is considered to be three-phase conductors over 100kV+, overhead or underground, that are bound by AC substations. Radial circuits above 100kV should be included. A single transmission DC circuit is considered to be one pole of the 100kV+, overhead or underground DC line that is bound by an AC/DC terminal on each end. Circuit breakers, transformers, and associated disconnect switches are not considered to be part of the circuit. A transmission circuit is considered to be out of service if it is de-energized and/or disconnected at one or more terminals. This definition is for MIDAS Section 1600 reporting only, it should align with TADS Section 1600 reporting, but may or may not align with other NERC reporting or compliance definitions.	Mandatory
Count of Transmission Transformers Removed From Service	The number of transmission transformers removed from service as a result of the Misoperation. A single transmission transformer is considered a bank comprised of three single-phase transformers or a single three-phase transformer with a 100kV+ low-side voltage. A transformer is bounded by its associated switching or interrupting devices. This definition is for MIDAS Section 1600 reporting only, it should align with TADS Section 1600 reporting, but may or may not align with other NERC reporting or compliance definitions.	Mandatory
Count of Conventional Generation Units and Inverter-Based Plants Removed from Service	The number of conventional generation units ≥ 20 MW and inverter-based (i.e. wind, solar) plants ≥ 20 MW removed from service as a result of the Misoperation. An inverter-based plant consists of one or more generators, inverters, or turbines with a shared point of interconnection. The plant's capacity should be based on the total MW capacity at the point of interconnection. Plants with multiple points of interconnection that are still able to provide energy to the BES should not be included in this count. This definition is for MIDAS Section 1600 reporting only, it may or may not align with other NERC reporting or compliance definitions.	Mandatory
Reported By	The name of the person who is reporting the Misoperation	Mandatory

Table 4.2: Misoperation Field Descriptions

Field Name	Description	Mandatory/ Voluntary/Calculated
Reporter's Phone Number	The phone number (###) ###-#### of the person who is reporting the Misoperation.	Mandatory
Reporter's Email	The email address of the person reporting the Misoperation (name@domain.com)	Mandatory
Date Reported	The date the Misoperation was reported to NERC (MM/DD/YYYY)	Mandatory
Corrective Action Plan	<p>Identification of the corrective actions. When a declaration was made stating no further corrective actions will be taken, this field should contain a description of the reason no actions were taken. If analysis is completed and the Unknown/Unexplainable cause code selected, investigative actions should be listed here.</p> <p>The CAP may be limited to corrective actions for the equipment that experienced the Misoperation but could also include corrective actions for other protection systems, depending on the review for applicability for other locations. Please consult your regional entity for guidance on whether or not they would like applicability for other locations included.</p>	Voluntary
Corrective Action Status	The status of the corrective action plan. Use Table G.8 to select appropriate status. This field should be updated as analysis progresses.	Mandatory
CAP Target Completion Date	If corrective actions are not complete, an estimate of when they will be complete. (MM/DD/YYYY)	Voluntary
CAP Actual Completion Date	The actual completion date of the corrective actions. (MM/DD/YYYY). If no corrective action is taken, the date submitted should be the date said determination was made.	Voluntary
Sub Cause	The subcause of the Misoperation. Use Table G.11 to identify the correct sub cause.	Voluntary
Communication Sub-Cause	If the cause of the Misoperation is "Communication Failure", the sub cause of the communication failure. Use Table G.12 to identify appropriate communication sub cause.	Voluntary
Communication System Type	If the cause of the Misoperation "Communication Failure", the type of communication system. Use Table G.13 to identify appropriate communication system type.	Voluntary
System Schemes	The Composite Protection System scheme that misoperated. A protective relay package may have a main protection function (such as a high speed protections scheme) and other protective functions (such as step distance or overcurrent). The function within the Composite Protection System that is responsible for the misoperation should be reported in the system schemes field. Use Table G.14 to identify appropriate system schemes.	Voluntary

Table 4.2: Misoperation Field Descriptions

Field Name	Description	Mandatory/ Voluntary/Calculated
Protection Systems and Components	Information on the Protection Systems/Components that Misoperated. If the "Cause of Misoperation" is "Relay failures/malfunctions", "Incorrect settings", "Logic errors", or "Design errors", and the cause is associated with a relay, list relay models (types). For non-relay component Misoperation causes, include specific information on non-relay Protection System components that Misoperated, such as "damaged CT secondary cable".	Conditionally Mandatory
Relay Technology	If the Cause of Misoperation is "Relay failures/malfunctions", "Incorrect settings", "Logic Errors", or "Design Errors", this field is used to identify the relay technology installed. Use Table G.15 to select the appropriate relay technology.	Voluntary
Microprocessor Relay Manufacturer	If the relay Technology is "Microprocessor" then select the name of the manufacturer. Use Table G.16 to select appropriate microprocessor relay manufacturer.	Voluntary
Additional Contact Name	The name of additional contact who has knowledge of the Misoperation.	Voluntary
Additional Contact's Phone Number	The phone number of the additional contact (###)###-####	Voluntary
Additional Contact's Email	The email address of the additional contact, name @domain.com	Voluntary
Comment	Free form text entered by the registered entity to provide clarification or additional information	Voluntary

Chapter 5: MIDAS Opt-Out Waivers

MIDAS provides quarterly opt out waivers. Opting out of Protection System Operations if there are no reportable Protection System Operations to report and Opting out of Misoperations if there are no reportable Misoperations are allowed by creating an opt-out waiver.

It is not allowed to opt out of Protection System Operations and not opt out of Misoperations. This follows the philosophy that for every Misoperation there is a corresponding operation.

Creating a Waiver

Table 5.1: Opt-Out Waiver Field Descriptions

Field Name	Description	Mandatory or Voluntary
Region	The entity's Regional Entity. If the entity is registered in multiple Regional Entities, the primary Regional Entity should be selected. It should be noted that this field should align with the selection made when submitting the file	Mandatory
Year	The calendar quarter for which the operation data is reported	Mandatory
Quarter	The calendar year for which the operation data is reported.	Mandatory

If there are no Protection System Operations to Report

If there are no Protection System Operations to report then there will also be no Misoperations to report. Opt out of reporting Protection System Operations and Misoperations by submitting a waiver. When creating a waiver, check off both boxes, to select opting out of Protection System Operations and Misoperations.

There is no need to submit an empty MIDAS reporting template when opting out of Protection System Operations and Misoperations.

If there are only Protection System Operations to Report

If there are no Misoperations to report and only Protection Systems Operations to report, opt out of submitting Misoperations by submitting a waiver. When creating a waiver, only check the box for opting out of Misoperations.

Opting out of Misoperations does not exempt Protection System Operations reporting. To submit reportable Protection System Operations, as they are still required, use the MIDAS Reporting Template or the Protection Systems Operations tab within the MIDAS portal.

Multi-Region Registered Entity Opt Outs

Multi-Region Registered Entities (MRREs) are required to submit one set of opt-outs for each Region they are registered in.

When submitting an opt-out for only Misoperations: submit only one opt-out for any Region detailed in the MRRE plan. Submit Protection System Operations in the Regions they occurred.

When submitting an opt-out for both Protection System Operations and Misoperations: submit only one opt-out for any Region detailed in the MRRE plan.

Appendix A: Glossary

For definitions of the following terms reference the official [NERC Glossary of Terms](#):

- Composite Protection System (CPS)
- Element
- Fault
- Misoperation
 - Failure to Trip – During Fault
 - Failure to Trip – Other Than Fault
 - Slow Trip – During Fault
 - Slow Trip– Other Than Fault
 - Unnecessary Trip – During Fault
 - Unnecessary Trip– Other Than Fault
- Protection System

The terms below are not included in the NERC Glossary of Terms:

AC System (Cause of Misoperation)

This cause includes Misoperations due to problems in the ac inputs to the Composite Protection System. Examples would include Misoperations associated with current transformer (CT) saturation, loss of potential or damaged wiring in a voltage or current circuit.

As-left Personnel Error (Cause of Misoperation)

This cause includes Misoperations due to the as-left condition of the Composite Protection System following maintenance or construction procedures. These include test switches left open, wiring errors not associated with incorrect drawings, carrier grounds left in place, settings placed in the wrong relay, or settings left in the relay that do not match engineering intended and approved settings. This includes personnel activation of an incorrect settings group.

Automatic (Restoration Method)

The system went back to normal without human intervention.

Breaker Failure (Protection System Scheme)

A scheme that identifies a breaker's failure to interrupt current within a set time after it has been commanded to trip.

Communication Failures (Cause of Misoperation)

This cause includes Misoperations due to failures in the communication systems associated with protection schemes, inclusive of transmitters and receivers. Examples would include Misoperations caused by loss of carrier, spurious transfer trips associated with noise, communications provider errors resulting in malperformance of communications over leased lines, loss of fiber optic communication equipment, or microwave problems associated with signal loss or degradation.

Communication Interface Failure (Modulator) (Communication Sub Cause of Misoperation)

Power-line carrier radios, fiber optic interfaces, microwave radios, audio-tone/telecommunications, and pilot wire components.

Communication Medium (Communication Sub Cause of Misoperation)

The external signal path, leased phone circuits, cables, transmission lines, etc.

Data Submission Quarter

The calendar quarter for which the operation data is reported.

Data Submission Year

The calendar year for which the operation data is reported.

DC System (Cause of Misoperation)

This cause includes Misoperations due to problems in the dc control circuits. These include problems in the battery or charging systems, trip wiring to breakers, trip coils, or loss of dc power to a relay or communication device. Please refer to Figure for additional clarification.

Design Errors (Cause of Misoperation)

This cause includes Misoperations due to incorrect physical design. Examples would include incorrect configuration on ac or dc schematic or wiring drawings, or incorrectly applied protective equipment.

Differential (Protection System Schemes)

A scheme that compares the phase and magnitude of local currents or voltages of the protected equipment (transformer, bus, capacitors, etc.).

Directional Comparison Blocking Scheme (DCB) (Protection System Schemes)

A pilot protection system in which the channel equipment (usually “on”- “off” power line carrier) is used to block tripping at the remote terminal for external faults. If a line terminal senses a forward fault and does not receive the blocking signal, the terminal is allowed to trip.

Directional Comparison Unblocking Scheme (DCUB) (Protection System Schemes)

A pilot protection system in which the channel equipment utilizes a frequency shift carrier system, with normal transmission of a guard (blocking) frequency. Overreaching elements are used at each end and a trip signal is transmitted when a fault is detected by the overreaching elements.

Direct Transfer Tripping Scheme (DTT) (Protection System Schemes)

A communication scheme to extend other protection schemes to remote terminals

Direct Under Reaching Transfer Trip Schemes (DUTT) (Protection System Schemes)

A scheme that uses local under reaching elements to trip locally, and to send direct transfer trip commands to the remote terminal.

Incorrect Settings (Cause of Misoperation)

This cause includes Misoperations due to errors in issued setting, including those associated with electromechanical or solid-state relays and the protection element settings in microprocessor-based relays (excluding logic errors discussed in the Logic Error cause code). This includes setting errors caused by inaccurate modeling.

Incorrect Logic Settings Issued (Communication Sub Cause of Misoperation)

This subcause code includes logic settings associated with communication function that have been incorrectly issued such as; channel addressing, channel timing, dip switches etc.

Incorrect Setting/logic/design-(Communication) Programming/Logic Error (Incorrect Setting/Logic Errors/Design Errors and Relay Failure/Malfunctions Sub Cause Code)

This category includes Misoperations due to incorrect programming or application of microprocessor- based communication equipment. These include multiplexer relay teleprotection devices.

Incorrect Setting/logic/design –Incorrect Physical Design (Incorrect Setting/Logic Errors/Design Errors and Relay Failure/Malfunctions Sub Cause Code)

This category includes Misoperations due to Incorrect Physical Design. This sub-cause code does not include construction personnel incorrectly wiring or failing to follow the construction drawing.

- Example 1: Drawing errors such as incorrect current transformer (CT) polarity, multiple groundings, wrong wiring diagram, etc.

Incorrect Setting/logic/design-Failure to Update Firmware Version by User (Incorrect Setting/Logic Errors/Design Errors and Relay Failure/Malfunctions Sub Cause Code)

This category includes Misoperations due to the wrong application of a relay firmware version. This category includes Misoperations due to user electing to not install correct firmware version despite notification of potential issues. . This category also includes having mismatched versions of firmware.

Incorrect Setting/logic/design-Incorrect Numeric Value Specified (Incorrect Setting/Logic Errors/Design Errors and Relay Failure/Malfunctions Sub Cause Code)

This category includes Misoperations due to Incorrect Numerical Value Specified of a Microprocessor Relay Setting. This sub-cause code does not include field personnel incorrectly inputting the relay settings.

- Example 1: Misoperation caused by incorrect specification of pickup magnitude, or protection operation time delay, or angle, or positive/negative/zero sequence parameters, etc.
- Example 2: Incorrectly specifying 5 ohms instead of 0.5 ohms.
- Example 3: Basing setting on incorrect parameter unit such as msec instead of cycle

Incorrect Setting/logic/design-Incorrect System Coordination (Incorrect Setting/Logic Errors/Design Errors and Relay Failure/Malfunctions Sub Cause Code)

This category includes Misoperations due to lack of Protection System coordination and/or modelling errors.

- Example 1: Studies are not up-to-date with actual fault values, or fail to consider mutual coupling, or do not take into account specific system configuration.
- Example 2: Failure to recognize the effect of changes due to transformer impedances and winding configurations

Incorrect Setting/logic/design-Incorrect User-Programmed Logic Specified (Incorrect Setting/Logic Errors/Design Errors and Relay Failure/Malfunctions Sub Cause Code)

This category includes Misoperations due to Incorrect Logic as specified by the user.

- Example 1: Misoperation caused by wrong function selection such as selection of positive/negative/zero sequence voltage for polarization, supervision element, loss of potential, trip logic, breaker failure logic, 2nd harmonic blocking, etc.

- Example 2: User programs incorrect I/O used for programmable logic. “Incorrect I/O” also implies that the engineer wires the correct inputs and outputs to the relay and he / she selects the associated input or output in the logic equations. The word bit that defines the specific input / output must also be correct in the logic equations.

Incorrect Setting/logic/design-Other (Incorrect Setting/Logic Errors/Design Errors and Relay Failure/Malfunctions Sub Cause Code)

This category includes Misoperations that are determined to be associated with Incorrect Setting/Logic/Design of a microprocessor relay, but they do not fit into any other category. Additional detail should be provided in the Event Description.

Line Current Differential (Protection System Schemes)

A scheme that measures the phase and magnitude of local line currents and compares with those at remote terminals.

Logic Errors (Cause of Misoperation)

This cause includes Misoperations due to issued logic setting errors associated with programming microprocessor relay inputs, outputs, custom user logic, or protection function mapping to communication or physical output points.

Manual (Restoration Method)

Manual operation of local or remote control switches

NERC ID

The entity’s NERC compliance registry (NCR) number. This should include the three letters “NCR” and any preceding or following 0’s.

Other (Protection System Schemes)

A protection system scheme not listed here is in place.

Other (Communication Sub Cause of Misoperation)

Any Communication Failures, which do not fit in the above Sub Causes.

Other/Explainable (Cause of Misoperation)

This cause includes Misoperations that were determined to have an identified cause but they do not fit into any of the above categories. For example, temporary changes in network topology that, because of their low probability of occurrence, are not accounted for in the design of the Protection System, 61850 errors, or environmental issues such as damage due to water from a leaking roof or animal intrusion.

Overcurrent (Protection System Schemes)

A protection scheme responsible for the Misoperation involving phase, ground or negative sequence instantaneous overcurrent or time overcurrent. Overcurrent protection used in communication-assisted schemes is excluded.

Permissive Schemes (POR/POTT/PUTT) (Protection System Schemes)

A scheme that uses elements at all terminals to send permissive signals to all remote terminals. The elements will trip without delay upon receipt of permissive signals from all remote terminals.

Phase Comparison (Protection System Schemes)

A scheme that compares the phase of the current entering each line terminal to identify internal/external faults.

Regional Entity Name

The entity's RE. If the entity is registered in multiple REs, the primary RE should be selected. It should be noted that this field should align with the selection made when submitting the file.

Relay-AC I/O Module Failure/Malfunction (Incorrect Setting/Logic Errors/Design Errors and Relay Failure/Malfunctions Sub Cause Code)

Failure or malfunction of an AC I/O module.

Relay – Communication Module Failure/Malfunction (Incorrect Setting/Logic Errors/Design Errors and Relay Failure/Malfunctions Sub Cause Code)

Failure or malfunction of a communication module within the relay itself.

Relay- (Communication) Loss of Synchronism (Incorrect Setting/Logic Errors/Design Errors and Relay Failure/Malfunctions Sub Cause Code)

This sub-cause code would capture Misoperations resulting from system which depend upon the integrity of the communications network.

- Example 1: A Misoperation of a current differential scheme due to loss of synchronism, or loss of time stamping.
- Example 2: Some phase comparison relays/differential relays require the same communication transport times in both directions. The communications channel route (communications in either direction) may be different dependent on how the communications network is switched, this may result in significantly different communication transport times in either direction. Loss of synchronism resulting in a Misoperation of these systems may occur if the communication transport times differ in each direction between two relays.

Relay-CPU Processor Failure/Malfunction (Incorrect Setting/Logic Errors/Design Errors and Relay Failure/Malfunctions Sub Cause Code)

This sub-cause code would capture Misoperations resulting from a failure of the main processor.

- Example 1: A temperature related failure, memory corruption, etc.

Relay-Digital I/O Module Failure/Malfunction (Incorrect Setting/Logic Errors/Design Errors and Relay Failure/Malfunctions Sub Cause Code)

Failure or malfunction of a digital I/O module.

Relay – Incorrect Manufacturer Design (Incorrect Setting/Logic Errors/Design Errors and Relay Failure/Malfunctions Sub Cause Code)

Misoperations resulting from wrong conceptual design in physical hardware, components, firmware, or software.

- Example 1: The various distance schemes that come prepackaged in a line protection system are incorrect.
- Example 2: Sensitive input prone to incorrectly operate for spurious voltage.

Relay-Incorrect Manufacturer Documentation (Incorrect Setting/Logic Errors/Design Errors and Relay Failure/Malfunctions Sub Cause Code)

Misoperations as a result of an action taken which was attributed to incorrect documentation from the manufacturer.

- Example 1: Incorrect description of relay logic in user manual.

Relay- Incorrect Manufacturer Programming (“Bug”) (Incorrect Setting/Logic Errors/Design Errors and Relay Failure/Malfunctions Sub Cause Code)

Misoperations as a result of a programming error in the device's firmware, internal programming, or user interface software. These are usually addressed by the manufacturer issuing a new firmware.

Relay- Other (Incorrect Setting/Logic Errors/Design Errors and Relay Failure/Malfunctions Sub Cause Code)

All other failures/malfunctions whose cause has been determined but which has no other "more appropriate" sub-cause code.

Relay-Power Supply failure/Malfunction (Incorrect Setting/Logic Errors/Design Errors and Relay Failure/Malfunctions Sub Cause Code)

Failure or malfunction of a power supply.

Relay- Self-Diagnostic Failure/Malfunction (Incorrect Setting/Logic Errors/Design Errors and Relay Failure/Malfunctions Sub Cause Code)

This sub-cause code would capture Misoperations resulting from an inappropriate action or inaction of the device self-diagnostics.

Relay-Unknown (Incorrect Setting/Logic Errors/Design Errors and Relay Failure/Malfunctions Sub Cause Code)

Misoperations caused by relay failure/malfunctions whose underlying sub-cause could not be determined.

Relay Failures/Malfunctions (Cause of Misoperation)

This cause includes Misoperations due to improper operation of the relays themselves. These may be due to component failures, physical damage to a device, firmware problems, or manufacturer errors. Examples would include Misoperations caused by loss of calibration, component degradation, misfiring thyristors, relay power supply failure, or internal wiring/logic error. Failures of auxiliary tripping relays fall under this category.

Station Signal Path Failure (Communication Sub Cause of Misoperation)

All signal carrying components within the substation fence including; cables, frequency filters, connectors, etc.

Step Distance (Protection System Scheme)

Non-pilot scheme to trip local breakers applying directional under reaching instantaneous elements and directional over reaching elements with definite time delays set to coordinate with remote protection system schemes.

Unknown/Unexplainable (Cause of Misoperation)

This cause includes Misoperations where no clear cause can be determined. Use this cause code if the analysis is still in progress. Ensure that cause code is updated, if necessary, once analysis is complete. If this cause code is selected following final analysis, description of extensive investigative actions should be included in the Corrective Action Plan.

Voltage Class

The system voltage of the protected BES Element.

Appendix B: Systematically Determining Misoperations

The following steps attempt to provide a generalized and systematic methodology to consistently determine whether or not a Misoperation has occurred. The method also instructs on how to determine the number of Composite Protection System Operations and Misoperations that should be reported.

Table B.1: Systematically Determining Misoperations		
Step		Methodology
1	Gather and Understand Available Information	When an operation has occurred, the reporter should begin by gathering available information necessary to determine if a Misoperation has occurred. This includes retrieving available information from relays and other field devices, referencing one line and wiring diagrams, and understanding the system conditions preceding the operation. Once the information has been gathered, the reporter should garner an understanding of the Composite Protection Systems associated with each Element effected by the event, including zones of protection generally delineated by current transformer locations.
2	Identify Composite Protection System Operations	The reporter should identify Composite Protection System Operations that occurred due to the event. A single composite protection system may comprise of more than one protection system (primary, backup, secondary, tertiary, etc.) either fully redundant or not.
3	Identify Composite Protection Systems That Failed to Operate	The reporter should identify any Composite Protection Systems that were intended to operate but failed to do so.
4	Determine If a Misoperation Has Occurred	The reporter should characterize all of the Composite Protection System Operations from step 2 and all of the failures to operate from step 3 as either correct Composite Protection System Operations or Misoperations. This should be done by comparing each one to the Misoperation categories as defined in the NERC Glossary of Terms.
5	Updating a Misoperation	<p>An entity can initially submit a Misoperation where the cause is not yet known using the Unknown/unexplainable cause category. In the Event Description Field, the entity should include the details known to them, and actions they plan to perform as they complete the investigation. Under Corrective Action Plan status, they would report this as Analysis – In Progress.</p> <p>When the investigation concludes, and if the cause of the Misoperation is identified, the entity needs to update the Misoperation submission in the MIDAS Portal.</p> <p>Necessary updates include:</p> <ul style="list-style-type: none"> • Adding relevant details to the Event Description field • Changing the cause category from Unknown/unexplainable to identified cause category
6	Detailing the Corrective Action Plan to include plan	These updates help ensure accurate and consistent reporting of protection system Misoperations. Failure to update these submissions can result in a

Table B.1: Systematically Determining Misoperations

Step		Methodology
	to address issues identified through the investigation	<p>higher than actual unknown/unexplainable rate for a Region or individual entity.</p> <p>If the cause of the Misoperation is not identified at the conclusion of the investigation, the cause category will remain Unknown/unexplainable. The corrective action plan should be updated with details of the investigation, including any actions taken to help identify the cause if there is a reoccurrence of the event. The corrective action status would be changed to Declaration made – no corrective actions.</p>

There are instances where the cause of the Misoperation is identified, but no corrective actions are taken. These rare instances involve conditions outside of the entities control or corrective actions would not improve BES reliability (see PRC-004-5(i) for examples). The reason for the declaration should be thoroughly documented in the event description to why no corrective actions and a declaration is made with no corrections were taken.

Appendix C: Composite Protection System Operations Examples

It is important to note that all of these examples, unless otherwise specified, are relating strictly to the Protection System components. In instances where a mechanical system operates incorrectly leading to the operation of an interrupting device, nothing should be reported to MIDAS.

General Examples

1. A breaker operates independently of the Composite Protection System due to a mechanical failure, such as a latch slip. This would not be reported at all as it was a mechanical failure of the breaker, meaning the Composite Protection System did not operate.
2. An Element, for example a capacitor bank, operates and locks out due to a Composite Protection System operation. The element remains de-energized for more than 24 hours. Upon re-energizing the Element the Composite Protection System immediately operates again. This should be reported as two Composite Protection System operations and, if applicable, two Misoperations because they occurred more than 24 hours apart.

Line Fault Examples

1. A permanent Fault occurs on Line A and all line breakers operate and go through a complete reclose sequence (trip, close, trip, close, and trip). This event is considered one Composite Protection System operation.
2. A Fault occurs on Line B and all line breakers operate correctly but, at the same time, a breaker on Line C operates. This event is considered two Composite Protection System operations, since two Elements' Composite Protection Systems were involved. The Line B Composite Protection System operation was correct and the Line C Composite Protection System operation was a Misoperation.
3. A breaker(s) on Line D opens under a non-Fault condition due to a failed relay. This event is considered one Composite Protection System operation. Analysis would identify the Line D Composite Protection System operation as a Misoperation. This means that one Composite Protection System operation and one Misoperations would be reported.
4. Line faults with one breaker failure;
 - a. No breaker failure relaying: There would be one Composite Protection System operation associated with the line Fault, and one additional Composite Protection System operation for each remote backup clearing operation.
 - b. Breaker failure relaying with local tripping and no transfer tripping of remote ends: These would be one Composite Protection System operation for the Fault, one Composite Protection System operation for the breaker failure local clearing, and an additional Composite Protection System operation for each remote backup clearing. For example, if the line Fault occurred and the breaker between two lines on a breaker-and-a-half bus failed, there would be three Composite Protection System operations. One Composite Protection System operation associated with the Fault, one Composite Protection System operation for the breaker failure local clearing, and one Composite Protection System operation for the remote end trip of the second line connected to the failed breaker.
 - c. Breaker failure with transfer tripping of remote ends: For the example scenario in 4b, there would be two Composite Protection System operations. One for the Fault, and a second for the breaker failure protection clearing.
5. A re-trip function implemented in a breaker failure scheme is part of the Composite Protection System that initiated the re-trip. For example, a fault occurs on Line E. The Protection Systems for Line E issue a trip signal to breakers at each terminal and initiate re-trip. If each breaker opens such that the breaker failure timer

does not expire and the Composite Protection System of no other Element operates, this event is considered one correct operation, regardless of whether the breakers were opened by the line relays or the re-trip functions.

6. A section of a BES ring bus or breaker and a half scheme is dedicated to supplying a non-BES transformer. When would an operation of the Composite Protection System of the transformer be reportable?
 - a. If the non-BES transformer differential protection zone includes the high-side lead and the bus section (high-side CTs of the transformer differential reside in the BES breakers), then any operation of the transformer differential protection is reportable.

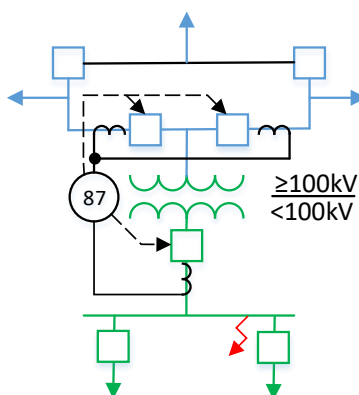

Figure C.1: Non-BES Transformer

- b. If the non-BES transformer differential protection zone ends at the high-side bushing of the transformer and the transformer leads and BES bus section is protected by separate differential protection, then any operation of the transformer differential is not reportable. Any operation of the transformer lead/bus differential would be reportable.

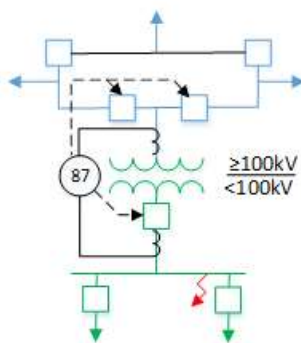

Figure C.2: Non-BES Transformer

7. Series Capacitor Bank Examples
 - a. A normal series capacitor bank bypass breaker close operation during a transmission line fault would not be considered an operation reportable in MIDAS. This is considered a control function implemented to prevent operating conditions from damaging components of the series capacitor.
 - b. Automatic opening of a series capacitor bank bypass breaker for any reason is a control function. Any operation or Misoperation of a series capacitor bank bypass breaker to open (to re-insert the series capacitor) is not reportable in MIDAS.
 - c. A series capacitor bank bypass breaker close operation caused by a failure of communications between the platform and the ground controls is considered a control function and is not reportable in MIDAS.

- d. A series capacitor bank bypass breaker close operation due to an electrical fault (responding to electrical quantities) on a series capacitor platform is reportable in MIDAS. Examples of electrical faults may include platform faults, capacitor unit failures, failures of protective surge arrestor, etc.
 - e. The failure of a series capacitor control function may lead to an electrical fault on a series capacitor platform. In this case, a composite protection system for the series capacitor may be called on to close the series capacitor bank bypass breaker. Understanding many of the components for control and system protection are shared, successful operations and Misoperations of the composite protection system under this condition are reportable in MIDAS.
8. Line 1 is protected by a two-zone directional comparison scheme at both Stations A and B, and by switch-on-to-fault protection at both Stations. The switch-on-to-fault protection is supposed to be armed only for a short period after the line is energized, and is to disarm thereafter. A fault occurs on Line 1 close to Station B. The fault is properly cleared by the Zone 2 element at Station A. However, at Station B, the fault is cleared by operation of the switch-on-to-fault scheme, which should have disarmed much earlier. The Zone 1 directional relaying at Station B which should have cleared the fault did not respond. This is nonetheless considered a single correct operation of the Line 1 Composite Protection System. There has been no Misoperation, since the performance of the Line 1 Composite Protection System was correct. (It is prudent that the Registered Entity investigate and correct the failure of the Zone 1 element and the unintentional operation of the switch-on-to-fault element at Station B.)

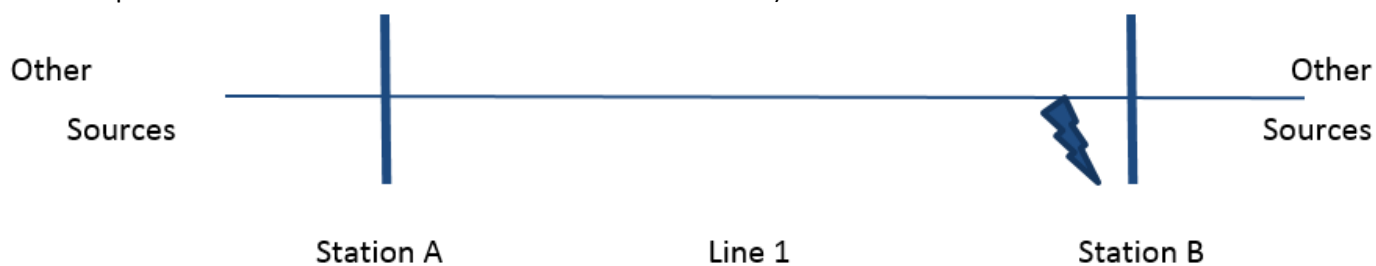

Figure C.3: Example 8 Diagram

Generator Examples

1. A BES generator's breakers trip due to a boiler issue. In this case the trip isn't generally initiated by a Protection System so it would not be reportable.
2. If, during normal shutdown, a reverse power relay operates, or fails to operate, as a control function it should not be reported.
3. If, during normal shutdown, a reverse power relay operates, or fails to operate, in order to protect the generator it should be reported as one operation.

Appendix D: Misoperations Examples

It is important to note that all of these examples, unless otherwise specified, are relating strictly to the Protection System components. In instances where a mechanical system operates incorrectly leading to the operation of an interrupting device, nothing should be reported to MIDAS.

General Examples

1. A line Fault occurs and breaker failure operates due to a failed trip coil. The trip coil is considered to be part of the station dc control circuitry for protective functions, therefore this is reported as a “Failure to Trip – During Fault” Misoperation. This means that two Composite Protection System operations and one Misoperation should be reported.
2. A line Fault occurs and breaker failure operates due to a mechanical failure (i.e. stuck breaker). The mechanical component is not considered part of the Composite Protection System so this is not a Misoperation. This means that two Composite Protection System operation and no Misoperation should be reported.
3. A line Fault occurs and the breaker experiences a slower operation due to a mechanical, non-electrical, issue (i.e. lack of lubrication) but no other Composite Protection System operated. The mechanical issue aside, Composite Protection System operates as expected. This would be reported as one Composite Protection System operation with no Misoperations.
4. Remote backup operates to clear a fault because the primary relay fails to operate for the faulted line. This would be reported as a Failure to Trip on the primary relay with one Misoperation and two Composite Protection System Operations.
5. A communications-assisted (high-speed) Composite Protection System fails to operate for a fault within its zone due to a communication failure and at least one other Element’s Composite Protection System operates on zone 2 time delay (Figure D.1). If it was determined that the Zone 2 delay settings were not coordinated, the cause would be Incorrect Settings. If communications-assisted high-speed scheme is required for coordination, then the cause of the Misoperation should be reported “Communication Failures”. (Dual high-speed schemes are common when high-speed protection is required for coordination.)

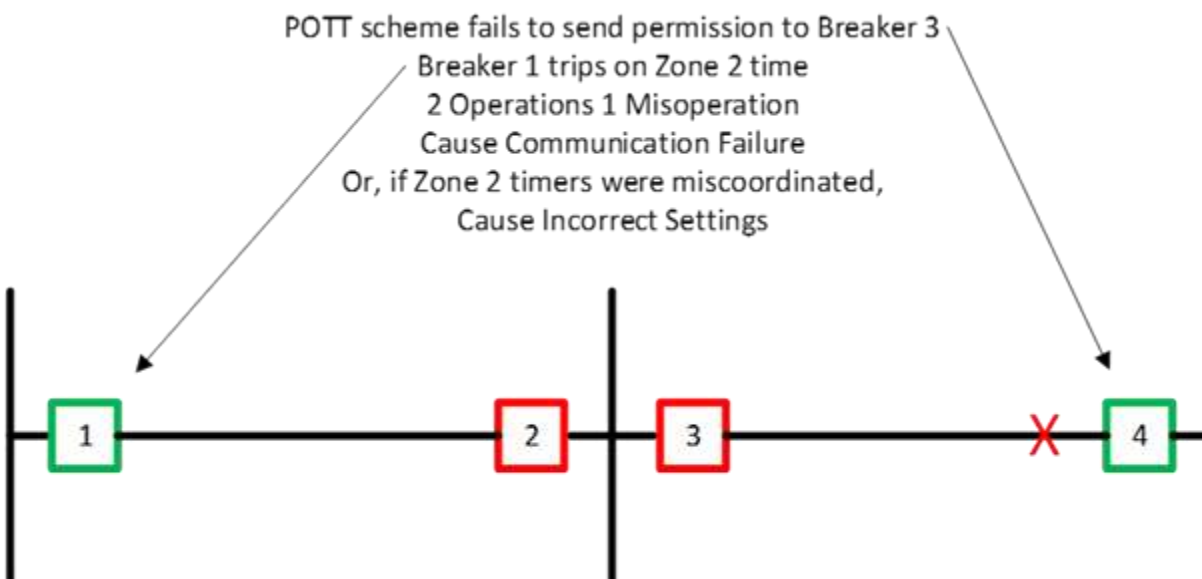

Figure D.1: Communication Failure

6. A communication assisted Composite Protection System trips during a fault or abnormal condition on an adjacent transmission line because of a communication failure. A Misoperation should be reported with the cause being “Communication Failures”.
7. A microprocessor relay trips or sends transfer trip due to a spuriously asserted binary input caused by transient voltage on the DC control circuitry. Since DC transients are not completely avoidable this Misoperation should be caused coded based on the apparent cause. Examples: If the control cable wasn’t properly shielded and should have been, this would be ‘Design errors’. If the relay input didn’t have proper debounce timer settings, ‘Incorrect settings’. If the relay input module failed and should not have asserted for this DC transient, ‘Relay failures/malfunctions’. Otherwise if the DC transient was beyond design expectations, use ‘DC system’.
8. A transformer that is not a BES Element is supplied from a BES ring bus operating at $\geq 100\text{kV}$. The zone of protection of the transformer differential (87) relay extends to the transformer high-voltage bushing current transformer. The differential relay operates due to poor current transformer performance during an out-of-zone fault on the low voltage system. This is not a Misoperation because the relay is not part of the Protection System for BES Elements.

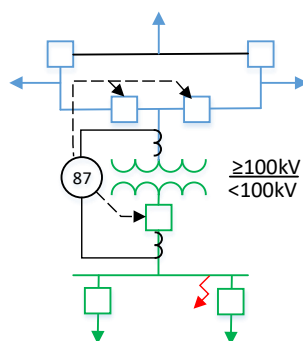

Figure D.2: Non-BES Transformer

9. A transformer that is not a BES Element is supplied from a ring bus operating at $\geq 100\text{kV}$. The zone of protection of the transformer differential (87) extends to the transformer high-voltage bushing current transformer.

The differential relay operates correctly in response to a fault within the transformer, issuing trip signals to the two ring bus breakers and the low voltage breaker. The ring bus breakers, which are BES interrupting devices, open correctly; the low voltage breaker fails to open. Because BES interrupting devices operated, the owner of the interrupting devices is obligated under PRC-004 to identify whether its Protection System component(s) caused a Misoperation. The owner determines that the low voltage breaker did not open due to a failed trip coil. This is not a Misoperation because the differential relay that generated the trip signal is not part of the Protection System for BES Elements.

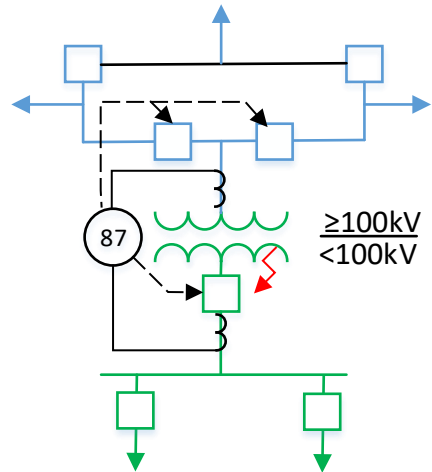

Figure D.3: Non-BES Transformer

10. A transformer that is not a BES Element is tapped from a BES transmission line operating at $\geq 100\text{kV}$. The zone of protection of the transformer differential (87) relay extends to the transformer high-voltage bushing current transformer, so the differential relay does not provide protection for BES elements. Since there is no interrupting device at the tap, the differential relay trips the line breakers via direct transfer trip. The differential relay operates due to incorrect current transformer polarity for an out-of-zone fault on the low voltage system. This is not a Misoperation because the relay is not part of the Protection System for BES Elements.

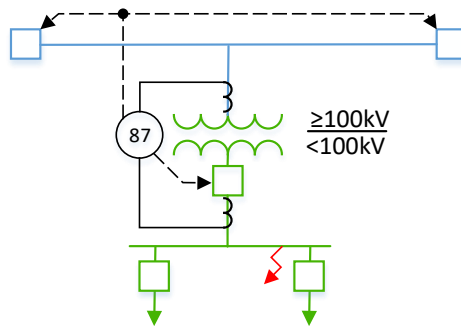

Figure D.4: Non-BES Transformer

11. A transformer that is not a BES Element is supplied from a ring bus operating at $\geq 100\text{kV}$. The zone of protection of the transformer differential (87) relay and a transformer overcurrent relay (51) includes part of the bus and the two ring bus breakers, so both relays provide protection for BES Elements. The relays may be discrete devices or implemented in a multifunction relay. The differential relay operates due to poor current transformer performance during an out-of-zone fault on the low voltage system. This is a Misoperation because the differential relay is part of the Protection System for BES Elements.

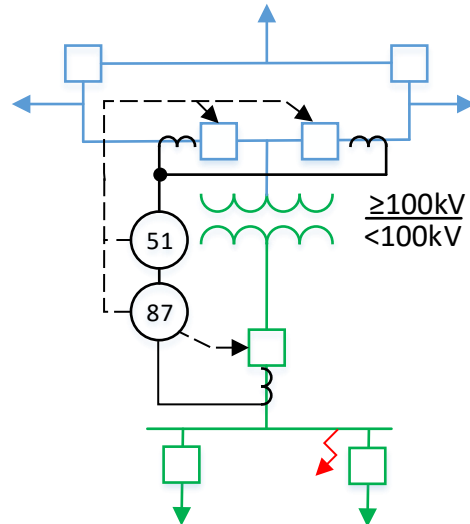

Figure D.5: Non-BES Transformer

12. A transformer supplying non-BES equipment is tapped from a transmission line operating at $\geq 100\text{kV}$. A distance relay is provided on the low voltage winding of the transformer. The relay trips the transformer low voltage breaker, which is not a BES Element, for an uncleared fault on the transmission line, which is a BES Element. The distance relay operates incorrectly and trips the low voltage breaker. This operation is not reportable under the Protection System Misoperation Section 1600 Data Request. No BES interrupting device has operated and therefore the operation cannot be identified as a Misoperation pursuant to PRC-004.

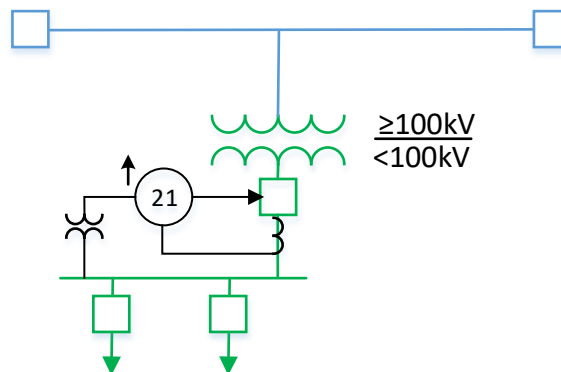

Figure D.6: Non-BES Transformer

13. A transformer supplying non-BES equipment is tapped from a transmission line operating at $\geq 100\text{kV}$. A distance relay is provided on the low voltage winding of the transformer to trip the transformer low voltage breaker, which is not a BES Element. The relay is provided to protect the transformer, although it is capable of tripping for an uncleared fault on some portions of the transmission line, which is a BES Element.

The distance relay operates correctly for a fault within the transformer, issuing a trip signal to the low voltage breaker. At the same time, other Protection Systems (not shown) detect the transformer fault and issue trip signals to the line breakers. These breakers, which are BES interrupting devices, open correctly; the low voltage breaker fails to open. Because BES interrupting devices operated, the owner of the interrupting devices is obligated under PRC-004 to identify whether its Protection System component(s) caused a Misoperation. The owner determines that the low voltage breaker did not open due to a failed trip coil. This

is not a Misoperation because the distance relay that generated the trip signal is not part of the Protection System for BES Elements.

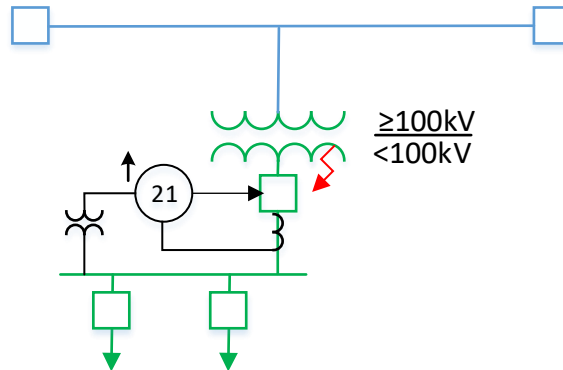

Figure D.7: Non-BES Transformer

14. A transformer that is not a BES Element is supplied from a ring bus operating at $\geq 100\text{kV}$. The zone of protection of the transformer differential (87) relay and a transformer overcurrent relay (51) includes part of the bus and the two ring bus breakers, so both relays provide protection for BES Elements.

The differential relay operates correctly in response to a fault within the transformer, issuing trip signals to the two ring bus breakers and the low voltage breaker. The ring bus breakers, which are BES interrupting devices, open correctly; the low voltage breaker fails to open. Because BES interrupting devices operated, the owner of the interrupting devices is obligated under PRC-004 to identify whether its Protection System component(s) caused a Misoperation. The owner determines that the low voltage breaker did not open due to a failed trip coil. This is a Misoperation because the differential relay that generated the trip signal is part of the Protection System for BES Elements .

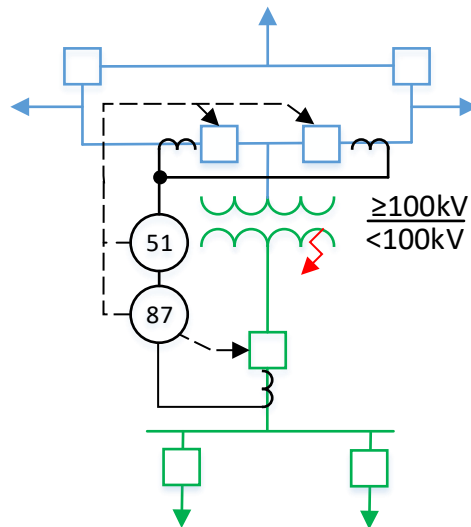

Figure D.8: Non-BES Transformer

15. A relay panel is bumped by a person (doing work in the substation unrelated to the relay) which causes an auxiliary tripping relay to trip a BES element out of service. The auxiliary tripping relay is part of a Composite Protection System and not part of a control. This is not a MIDAS reportable operation or Misoperation. The definition for unnecessary trip – other than fault includes: “A Composite Protection System operation that is

- caused by personnel during on-site maintenance, testing, inspection, construction or commissioning activities is not a Misoperation.” The definition does not state the activity conducted on-site needs to be associated to the relay that operated. If that person was not on-site for the activity, the operation would have never occurred.
16. A Protection System unnecessarily trips a breaker due improper actions of personnel performing on-site maintenance, testing, inspection, construction, or commissioning activities. This would not be a reportable operation.
 17. A Protection System unnecessarily trips a breaker due to an existing error in relay settings or logic, when that error is revealed by actions of personnel performing on-site maintenance, testing, inspection, construction, or commissioning activities. This would not be a reportable operation.
 18. A Protection System unnecessarily trips a breaker during switching performed in preparation for on-site maintenance, testing, inspection, construction, or commissioning activities. This would not be a reportable operation.
 19. A Protection System unnecessarily trips a breaker during switching performed for recovery from on-site maintenance, testing, inspection, construction, or commissioning activities before the equipment is released for service. This would not be a reportable operation.
 20. A Protection System unnecessarily trips a breaker during switching for any purpose, if the operation is due to an error in switching. Errors in switching include, for example, incorrect order of steps in the switching procedure, or incorrect execution of a switching procedure by personnel.” This would not be a reportable operation.
 21. A fault occurs on a remote line, but the relay at the station where personnel happened to be working, malfunctions for a cause unrelated to the on-site personnel and does not send a block-trip signal to the remote end. The Misoperation that occurred as a result of the malfunction of the relay that did not send the block, would need to be reported. Having personnel on-site when a Misoperation occurs does not, in and of itself, mean the Misoperation does not have to be reported. Any Misoperation that occurs while personnel are on-site, but was not directly caused by the actions of the onsite personnel, must still be reported.
 22. Protection System operations due to current imbalance created by unbalanced operational switching (such as unbalanced 3 phase device operation) are not reportable Protection System Operations or Misoperations because of the maintenance exclusion.
 23. A re-trip function implemented in a breaker failure scheme is part of the Composite Protection System that initiated the re-trip. For example, if both the relay that initiated the re-trip and the re-trip function failed to operate properly this would be reported as one Misoperation.
 24. During substation construction activities, work crews temporarily shunted and grounded CTs of two open BES breakers at the breakers. The same bus differential CT circuits were also grounded at one location in the control house. A fault occurred outside the differential zone of protection. Because of the shunted and grounded CTs at the breaker, the bus differential relay operated. Although this operation is caused by personnel during construction, the operation occurred during a fault. This event should be reported in MIDAS as a Misoperation.
 25. Line 1 is protected by a two-zone directional comparison scheme at both Stations A and B. A fault occurs on Line 1 beyond the intended reach of the zone 1 Element at Station A. The fault is cleared by the Zone 1 elements at both Stations A and B. This is reported as one operation, and no misoperations. The overreach of the Station A Zone 1 Element does not constitute a Misoperation, since the performance of the Composite Protection System was correct. There has been one correct operation of a Composite Protection System, nothing more. (It is prudent on the Registered Entity to investigate and correct the overreach of the Station A Zone 1 element.)

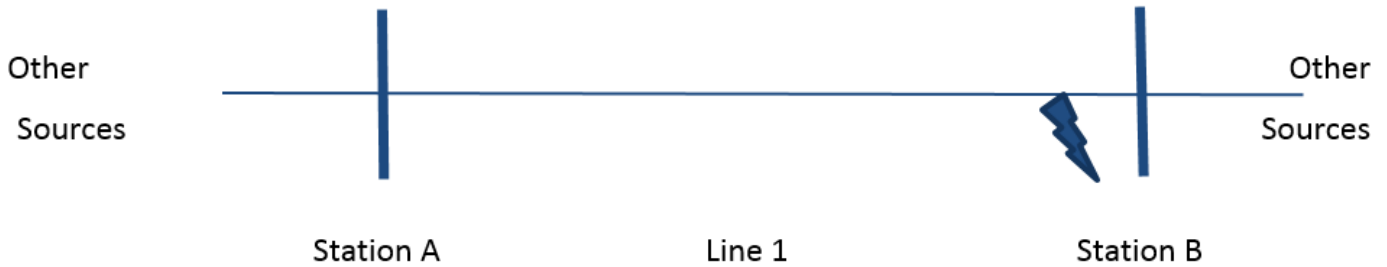

Figure D.9: Two-zone Directional Comparison Scheme

26. Lines 1 and 2 are both protected by two-zone directional comparison schemes at Stations A, B, and C. A fault occurs on Line 2 at its midpoint between Stations B and C. Zone 1 elements on Line 2 at Stations B and C respond instantaneously, resulting in the immediate operation of the Line 2 Breakers at both Stations B and C, which clear the fault in normal operating time. However, the Zone 2 Element on Line 1 at Station A also responds to the fault, tripping the Line 1 Breakers at Station A. This is reported as two Composite Protection System operations (Composite Protection Systems of Line 1 and Line 2). That of Line 2 is a correct operation; that of Line 1 is a Misoperation, since it is an unnecessary Composite Protection System operation for a Fault condition on another Element.

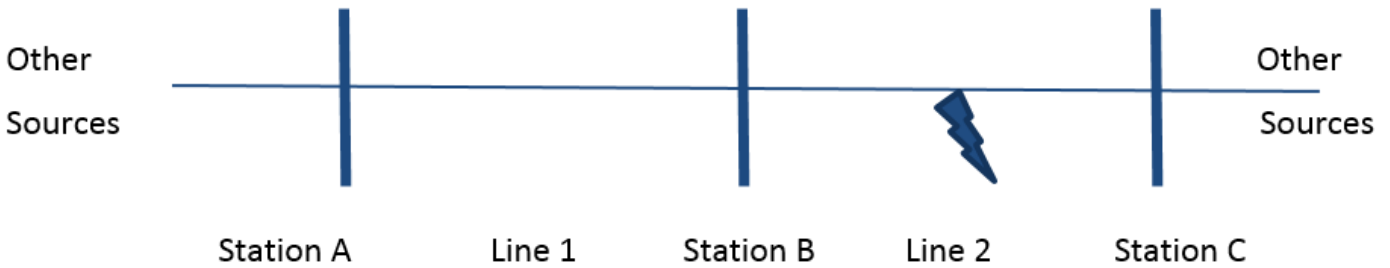

Figure D.10: Two-zone Directional Comparison Scheme

27. Lines 1 and 2 are both protected by two-zone directional comparison schemes at Stations A, B, and C. A fault occurs on Line 2. The fault is cleared properly at Station C, but the protection system of Line 2 at Station B fails to respond. Eventually, the Zone 1 directional relay associated with Line 1 at Station B responds to the fault on Line 2 against direction and trips its associated breakers, clearing the fault. Ordinarily, the operation against direction of the Line 1 directional relay at Station B would constitute a Misoperation, as a Composite Protection System operation for a fault on another Element. To constitute a Misoperation, the operation for a fault on another element must be unnecessary. In this instance the operation was necessary to clear the fault. Consequently, two Composite Protection System operations should be reported; an incorrect Composite Protection System on Line 1 and a correct operation on Line 2.

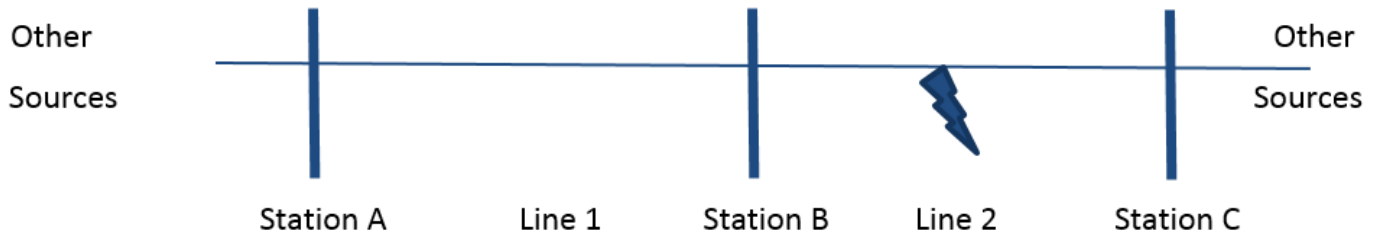

Figure D.11: Two-zone Directional Comparison Scheme

28. A static var compensator (SVC) initiates a trip signal to a BES interrupting device due to the failure of a component that monitors DC voltage in the control system of the SVC. This is not a reportable Misoperation because it was initiated by a non-protective function.
29. A phase-ground fault occurs on a two-terminal line that is protected by a directional comparison blocking scheme. A directional relay at Terminal A terminal makes an incorrect directional decision and sends an extended block signal to Terminal B. The breaker at Terminal A is tripped by time-delayed relays. Even though the protection system of the line operates more slowly than expected, the protection systems of no other Elements operate. This is not a Misoperation because the Composition Protection System for the line operated correctly.
30. A high-impedance phase-ground fault occurs on a two-terminal line that is protected by ground-overcurrent relays. Due to the low level and varying nature of the current, the overcurrent relay operates, but does so more slowly than expected. Because of slower than expected operation, the protection system on an adjacent line also operates. This is a Misoperation: Slow Trip- During Fault.
31. The sensitively set neutral overvoltage protection of a capacitor bank trips when a jumper fails open on an adjacent line. Since a broken jumper is included in the definition of a Fault, this is a Misoperation: Unnecessary Trip- During Fault.
32. A line disconnect auxiliary contact provides incorrect status, caused by the mechanical linkage being out of adjustment, which causes the line's stub bus protective function to unnecessarily trip. This is not a Misoperation because the failed component is the mechanical linkage and is not part of the Protection System.
33. A line disconnect auxiliary contact provides incorrect status, caused by corrosion in the contact, which causes the line's stub bus protective function to unnecessarily trip. This is a reportable Misoperation because the failed component was part of the control circuitry associated with protective functions.
34. A 115kV potential transformer lead pulled out of the connecting lug during high winds. The BES bus relay operated, tripping the bus due to sensed loss of the phase voltage after the 115kV potential transformer lead fell. Although the relay operated correctly based on the BES voltage at the source of the instrument transformers, there was not a fault. An operation and a misoperation should be reported in MIDAS with a cause of "AC System".
35. Operation of capacitor bank voltage differential protection caused by failure of the potential measuring device (1) or resistor (2) shown in Figure D.12 below is a Misoperation with a cause of "AC System". Operation of capacitor bank voltage differential protection caused by failure of the low-voltage cans (3) is a correct operation as the low-voltage cans are not part of the Protection System.

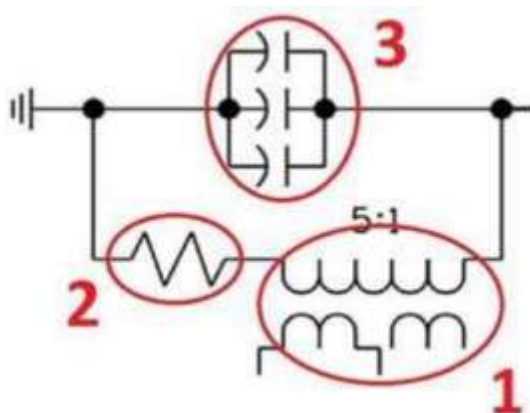

Figure D.12: Capacitor Bank Voltage Differential Protection

Generator Examples

1. If a generator relay trips with no fault occurring during reactive power testing in accordance with MOD-025, is this a reportable Misoperation? If a relay operates during the generator testing is it considered a Misoperation?
 - a. If a generator trips with no fault during MOD-025 reactive power capability verification testing, this would be a reportable Misoperation.
 - b. If the generator exceeded its limitations or experienced an abnormal condition, such as a loss of field for which a generator relay is set to trip, this would be reported as a single Protection System Operation and no Misoperation.
2. An individual dispersed power producing resource rated 2MVA (included in the BES under inclusion I4 of the BES definition) is removed from service due to a misoperation of its composite protection system. If other generation units associated with the same BES delivery system are not affected, then the misoperation is not reportable in MIDAS. However, if more than 75MVA of aggregated capacity is removed from service due to a common mode misoperation then it would be reportable in MIDAS as a misoperation and included in the total composite protection system operations.

Environmental Examples

1. Transformer 1, which serves as the GSU for Unit 1 Alpha Powerplant, tripped on a differential. It was determined that the trip was the result of water ingress into the transformer terminal cabinet, shorting multiple wires, including CTs and PTs. This Misoperation would be classified as “Other/Explainable” with the description stating it was caused by water.
2. Current transformer wiring at substation Bravo was damaged by a rodent resulting in erroneous transfer trip to substation Alpha. This Misoperation would be classified as “Other/Explainable” with the description stating it was caused by a rodent.

Appendix E: Reporting on Tie-Lines

To ensure accurate calculation of the Misoperation rate, the operation of a Composite Protection System on any BES Element must be reported as one operation. This is true regardless of the ownership of the various terminals of the Element. Since the various TO, GO, and DP that own different terminals of an Element are individually obligated to report operations and Misoperations under the Section 1600 data request, neighboring entities must coordinate reporting to ensure accurate calculations for the bulk power system as a whole and for individual entities.

The responsibility of reporting Misoperations and developing an associated Corrective Action Plan (CAP) falls on the entity that owns the specific equipment that Misoperated. The entity that owns the equipment that Misoperated should also report the associated Composite Protection System Operation. This is in alignment with the Section 1600 Data Request as well as PRC-004.

Reporting correct Composite Protection System Operations on shared equipment can be done using one of the methods described below, although entities are recommended to adopt the 1/N method. Agreement between entities to use the 1/N method streamlines the counting of operations and alleviates the tracking and reoccurring coordination between entities required for other methods

1/N Method (Recommended)

Entities can report correct operations on an Element with shared ownership based on the fraction of terminals of the Element that the entity owns. Since this method could result in the total operations during a reporting period including a fractional number of operations, fractional operations are rounded to the closest whole number for reporting. In subsequent reporting periods, the entity should round fractional operations in such a way that the total number of operations reported over several time periods is an accurate representation of the actual number of operations (e.g. round up this time, round down next time, etc).

Example for the 1/N Method

Entities A and B each own the protection system components at one terminal of a two-terminal line. During reporting period 1, there is a fault on the subject line. The protection system components at both terminals operate correctly for the fault.

In this example, each entity would record $\frac{1}{2}$ operations for this event. Once a total number of operations for the quarter were summed for one of the entities of this tie line resulted in a total of $32\frac{1}{2}$ total operations then the entity would submit 33 operation for that quarter. Additionally, the entity would identify that the next time this rounding occurred, the rounding would be down to the next whole number.

Note: This same methodology can be used for multiple owners of 2 or 3, of 4 terminal lines.

Table E.1: Tie Line Reporting 1/N Method

Reporting Period	Actual Operations	Reported Operations	Rounding
1	32 $\frac{1}{2}$	33	Rounded Up
2	24 $\frac{1}{2}$	24	Rounded Down
Total	57	57	Accurate Total

Appendix F: Reporting as a Multi-Region Registered Entity

Entities identified as MRREs may or may not have Protections System Operations and/or Misoperations in multiple Regions. MIDAS reporting is not one of the delegated functions that falls under coordinated oversight and is expected to be done based on the location in which events occur.

Reporting Composite Protection System Operations

Entities identified as a MRRE are to report Composite Protection System Operations in the Regions where they occurred. In the case of tie-lines where the Composite Protection System spans multiple Regions, the entity should use one of the methods described in Appendix E to determine the reporting Region.

Pre-Determined Method

Entities can decide in advance which entities are responsible for reporting correct operations and Misoperations on a given Element with shared ownership.

Reporting Misoperations

Entities identified as a MRRE are to report Misoperations in the Regions in which they occurred. In the case of tie-lines where the Composite Protection System spans multiple Regions, the Misoperation should be reported in the Region in which the component that misoperated is located.

Definitions

Multi-Region Registered Entity -A registered entity—or two or more registered entities that are corporate affiliates—performing BES functions in two or more REs that has been approved for coordinated functions and responsibilities by the ERO Enterprise. It is acknowledged there are other registered entities that are corporate affiliates and performing BES functions in two or more REs that are not included in the Program.

Coordinated oversight -The agreed upon steps and activities that a lead RE and affected REs follow for coordinating activities associated with delegated functions (e.g., compliance and enforcement, system events, etc.) for MRREs that have been approved for participation in the Program.

Appendix G: Reference Tables

Table G.1: Time Zones

Time Zone	Abbreviation	Difference from UTC
Atlantic Daylight Time	ADT	-3
Atlantic Prevailing time	APT	-3/-4
Atlantic Standard Time	AST	-4
Eastern Daylight Time	EDT	-4
Eastern Prevailing Time	EPT	-4/-5
Eastern Standard Time	EST	-5
Central Daylight Time	CDT	-5
Central Prevailing Time	CPT	-5/-6
Central Standard Time	CST	-6
Mountain Daylight Time	MDT	-6
Mountain Prevailing Time	MPT	-6/-7
Mountain Standard Time	MST	-7
Pacific Daylight Time	PDT	-7
Pacific Prevailing Time	PPT	-7/-8
Pacific Standard Time	PST	-8
Greenwich Mean Time	GMT	0

Table G.2: Regions

Region	Abbreviation
Midwest Reliability Organization	MRO
Northeast Power Coordination Council	NPCC
ReliabilityFirst	RF
SERC Reliability Corporation	SERC
Texas Reliability Entity	TRE
WECC	WECC

Table G.3: Jurisdiction

United States
Mexico
Canada
Other

Table G.4: Equipment Type

Line	Shunt Reactor/Inductor
Transformer	Dynamic Var Systems
Generator	Breaker
Shunt Capacitor	HVdc
Series Capacitor	BES UFLS
Bus	BES UVLS
Series Reactor/Inductor	Other

Table G.5: Facility Voltages

<100kV (BES)
<100kV (non-BES)
100kV
115kV
120
138
161
230
345
500
735
765
HVdc

Table G.6: Misoperations Categories

Failure to Trip-During Fault
Failure to Trip-Other than Fault
Slow Trip- During Fault
Slow Trip- Other than Fault
Unnecessary Trip-During Fault
Unnecessary Trip-Other Than Fault

Table G.7: Misoperation Cause Codes

AC system
As-left personnel error
Communication failure
DC system
Incorrect settings
Logic errors
Design errors
Relay failures/malfunctions
Unknown/unexplainable
Other/Explainable

Table G.8: Corrective Action Status

Analysis-In Progress
Analysis-Completed
Corrective Action-In Progress
Corrective Action-Completed
Declaration made-No corrective actions

Table G.9: Fault Types

3 Phase (3PH)
3Phase to Ground (3PH-GND)
Phase to Phase (PH-PH)
Phase to Phase to Ground(PH-PH-GND)
Phase to Ground(PH-GND)

Table G.9: Fault Types

Unknown (UNK)
Other(OTH)
None

Table G.10: Restoration Method

Automatic
Manual
NA

Table G.11: Misoperation Sub-Cause Codes

Incorrect setting/logic/design - Other
Incorrect setting/logic/design-Incorrect Numeric Value Specified
Incorrect setting/logic/design-Incorrect User-Programmed Logic Specified
Incorrect setting/logic/design-Incorrect System Coordination
Incorrect setting/logic/design-Incorrect Physical Design
Incorrect setting/logic/design-Failure to Update Firmware Version by User
Incorrect setting/logic/design-(Communication) Programming/Logic Error
Relay-Power Supply failure/Malfunction
Relay- AC I/O Module Failure/Malfunction
Relay- Digital I/O Module Failure/Malfunction
Relay- Communication Module Failure/Malfunction
Relay-(Communication) Loss of Synchronism
Relay- Self-Diagnostic Failure/Malfunction
Relay- CPU Processor Failure/Malfunction
Relay-Continuous Reboot
Relay- Incorrect Manufacturer Programming (“Bug”)
Relay-Incorrect Manufacturer Design
Relay-Incorrect Manufacturer Documentation
Relay-Unknown
Relay-Other

Table G.12: Communication Sub-Cause Codes

Communication Interface Failure
Communication Medium
Incorrect Logic Setting Issued
Other
Station Signal Failure

Table G.13: Communication System Types

Fiber Optic
Microwave
Phone line
Pilot Wire

Table G.13: Communication System Types

Power Line Carrier
Unknown/Other

Table G.14: Protection System Schemes

DTT
DCUB
DCB
POR/POTT/PUTT
DUTT
Phase Comparison
Differential
Step Distance
Other
Breaker Failure
Line Current Differential
Overcurrent

Table G.15: Relay Technology

Electromechanical
Solid State
Microprocessor
N/A
Other

Table G.16: Microprocessor Relay Manufacturer

ABB
AREVA
Basler
GE
RFL
SEL/Schweitzer
Siemens
Alstom
Schneider
ERL Phase
Beckwith
Unknown
Iniven

Appendix H: Misoperation Characterization Flow Diagram

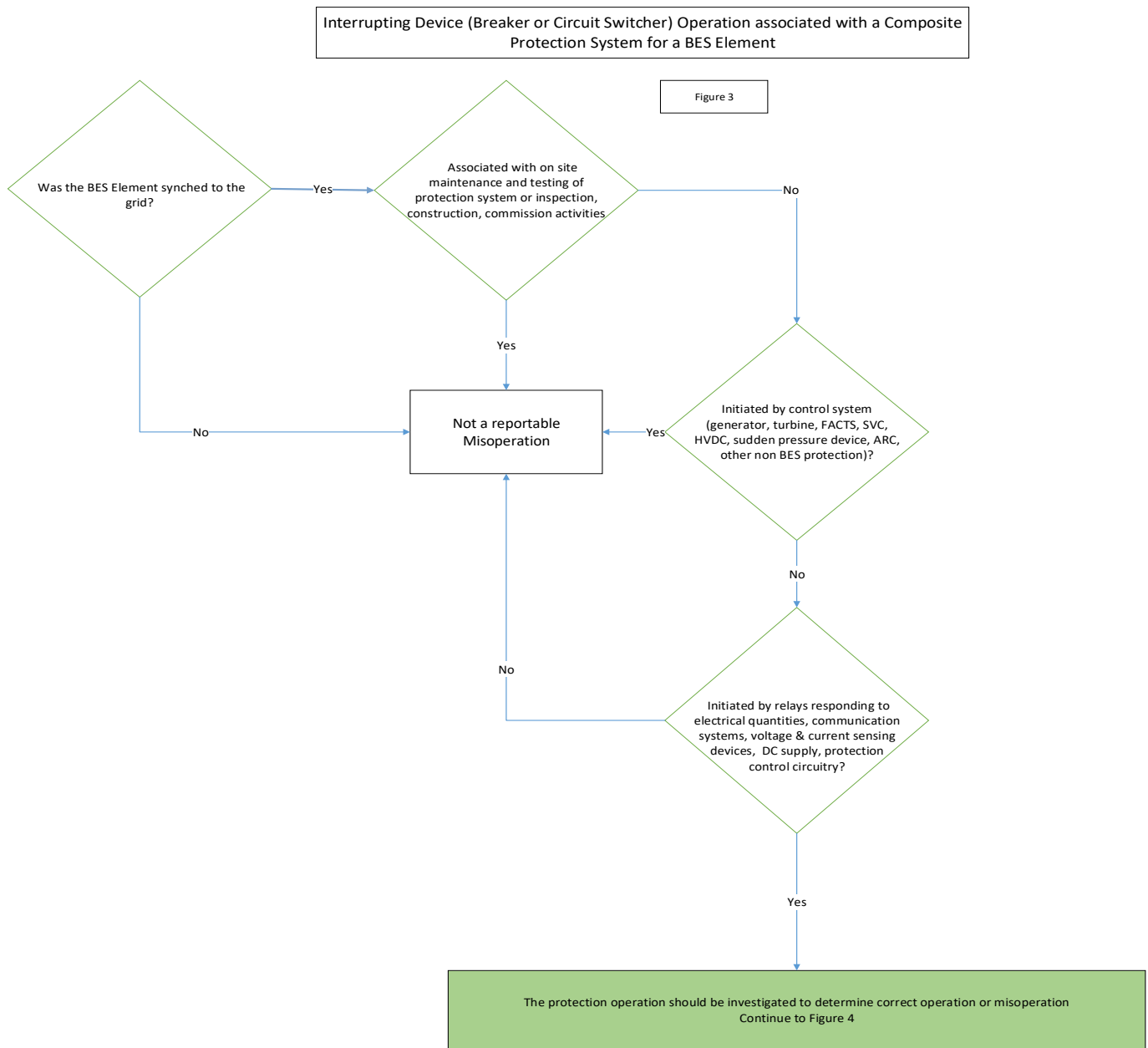
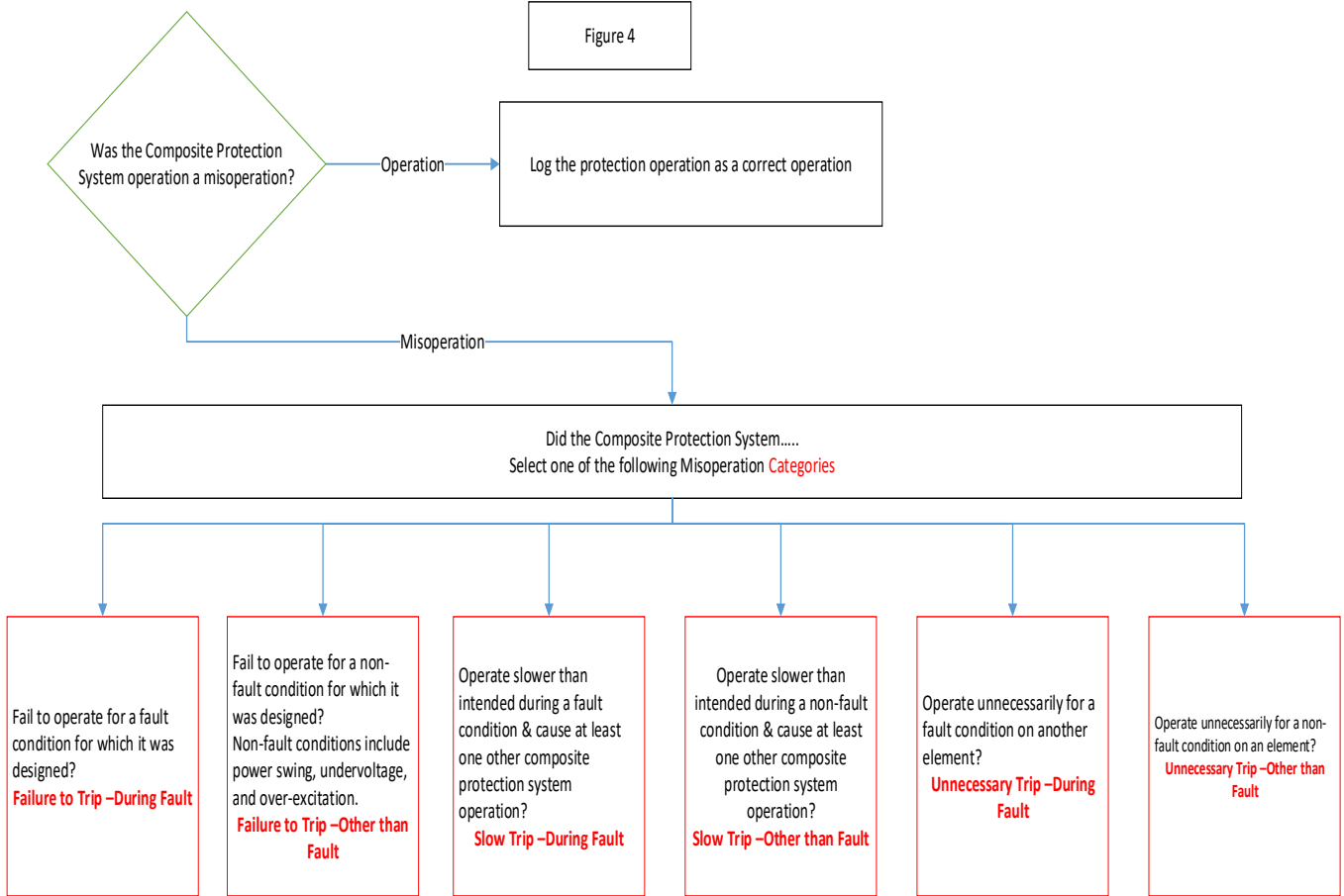

Figure H.1: Interrupting Device (Breaker or Circuit Switcher) Operation associated with a Composite Protection System for a BES Element

The protection operation should be investigated to determine correct operation or misoperation

Figure 4



Determine the Cause of the Misoperation
Continue to Figure 5

Figure H.2: Misoperation Categories

The protection operation should be investigated to determine correct operation or misoperation

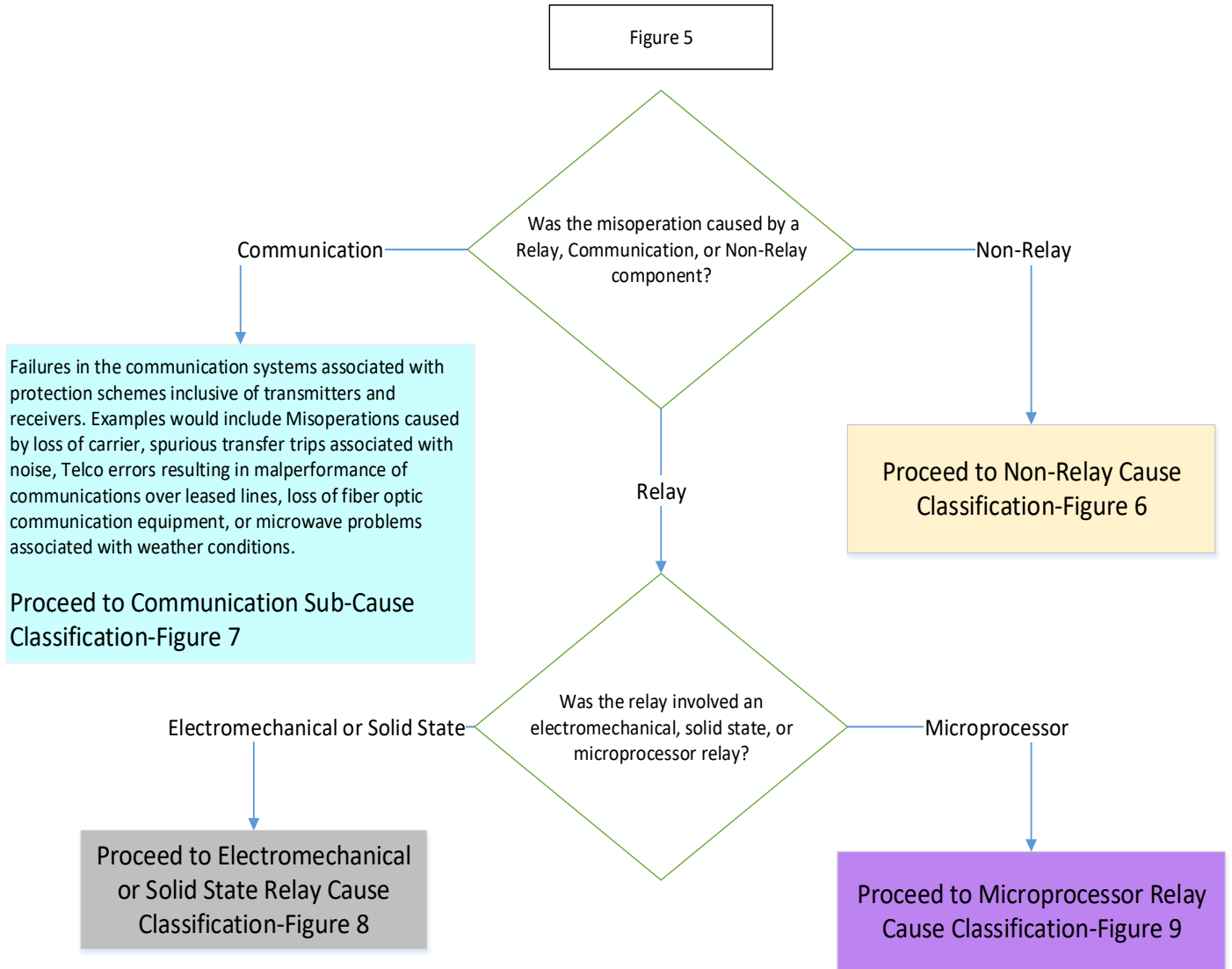

Figure H.3: Misoperation Types

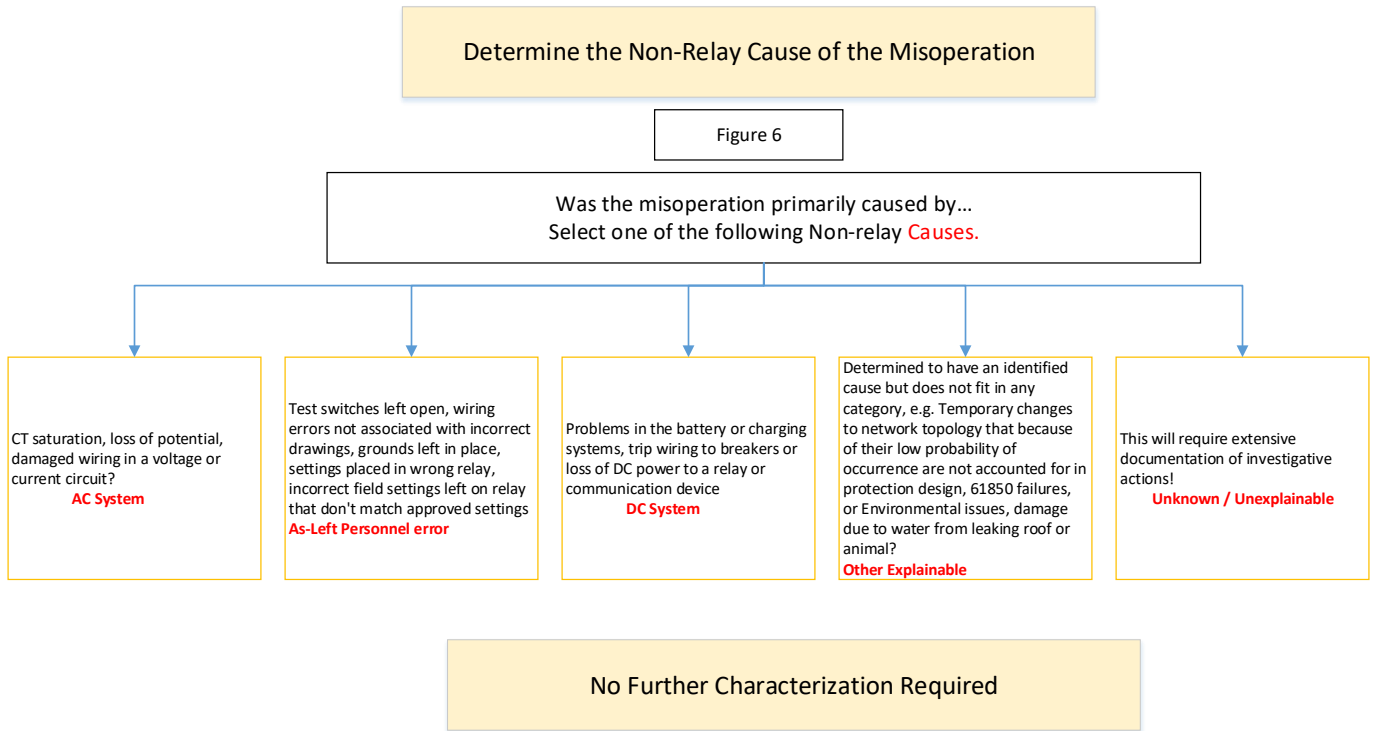

Figure H.4: Non-Relay Cause of Misoperation

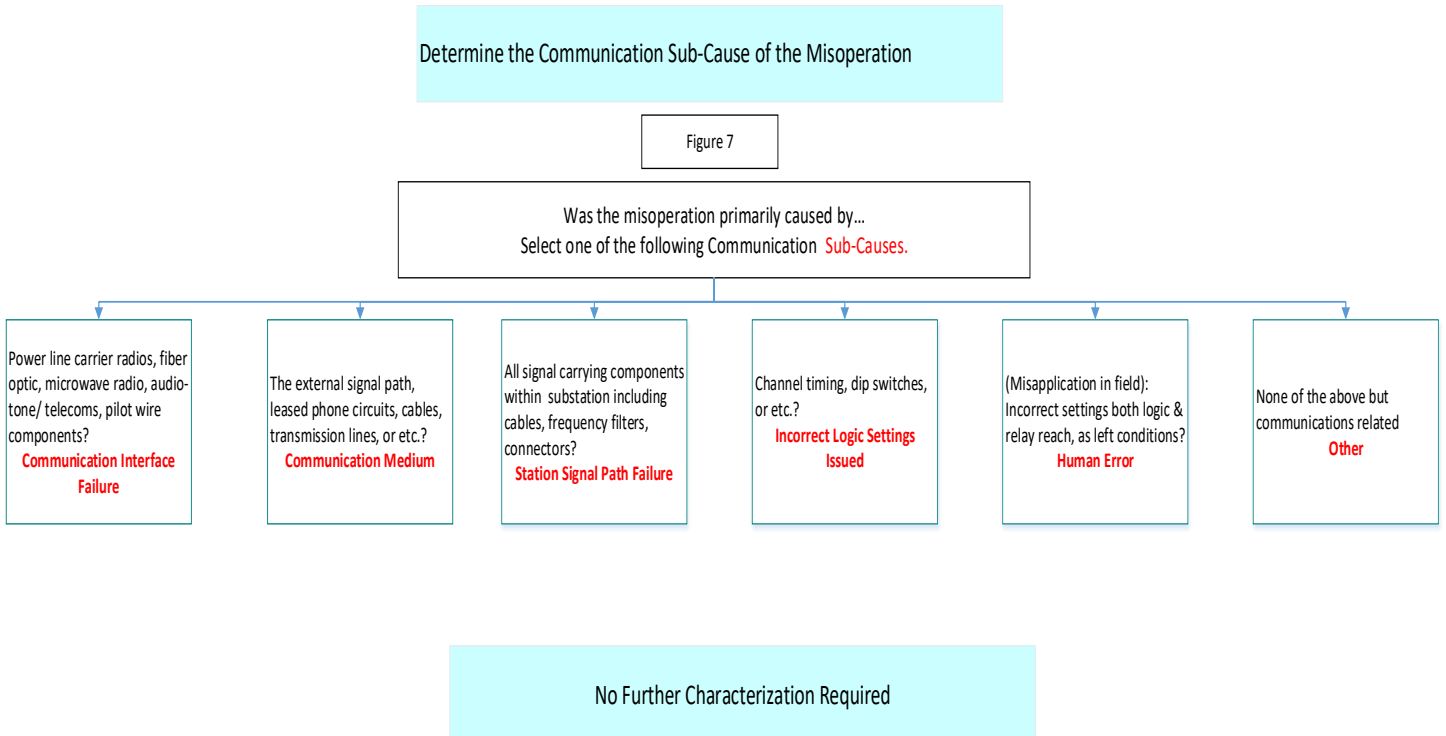

Figure H.5: Communication Sub-Cause of Misoperation

Determine the Electromechanical or Solid State Relay Cause of the Misoperation

Figure 8

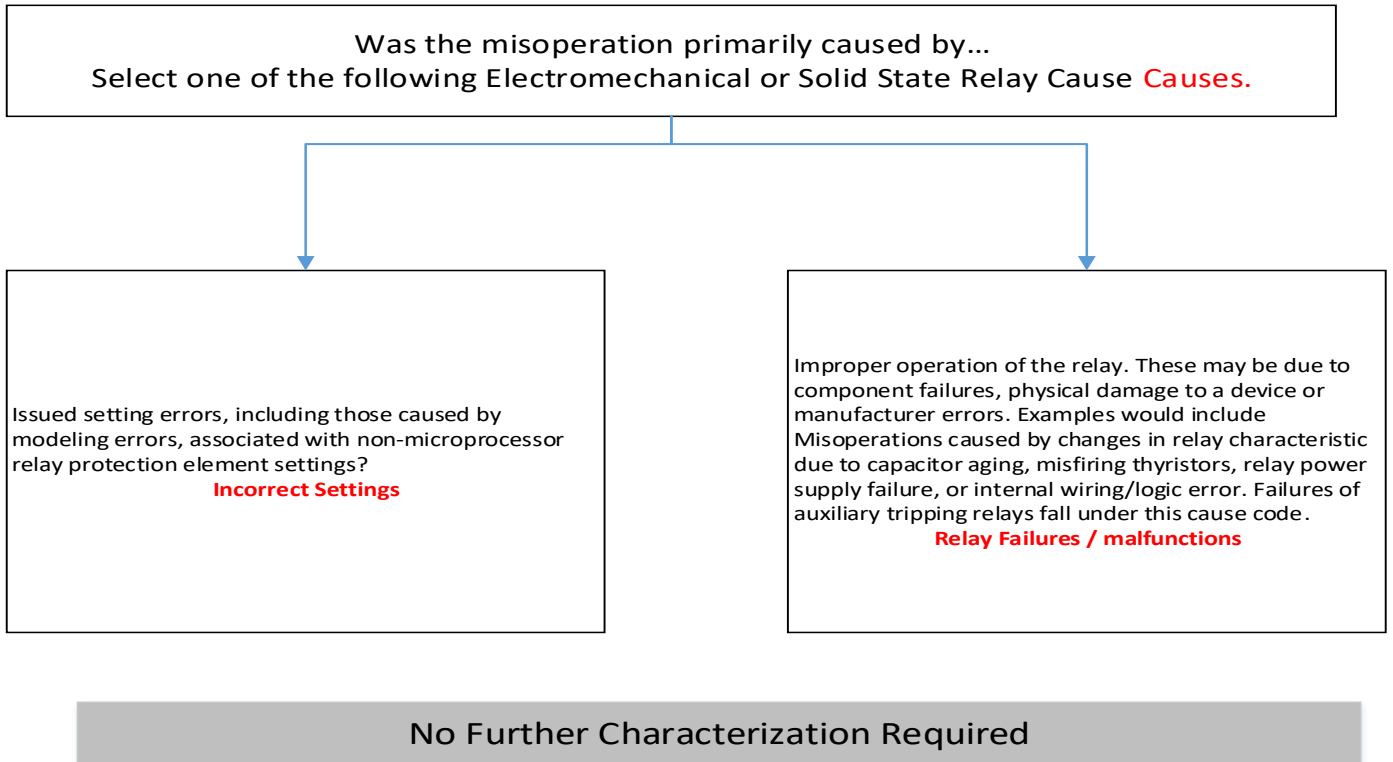

Figure H.6: Electromechanical or Solid State Relay Cause of Misoperation

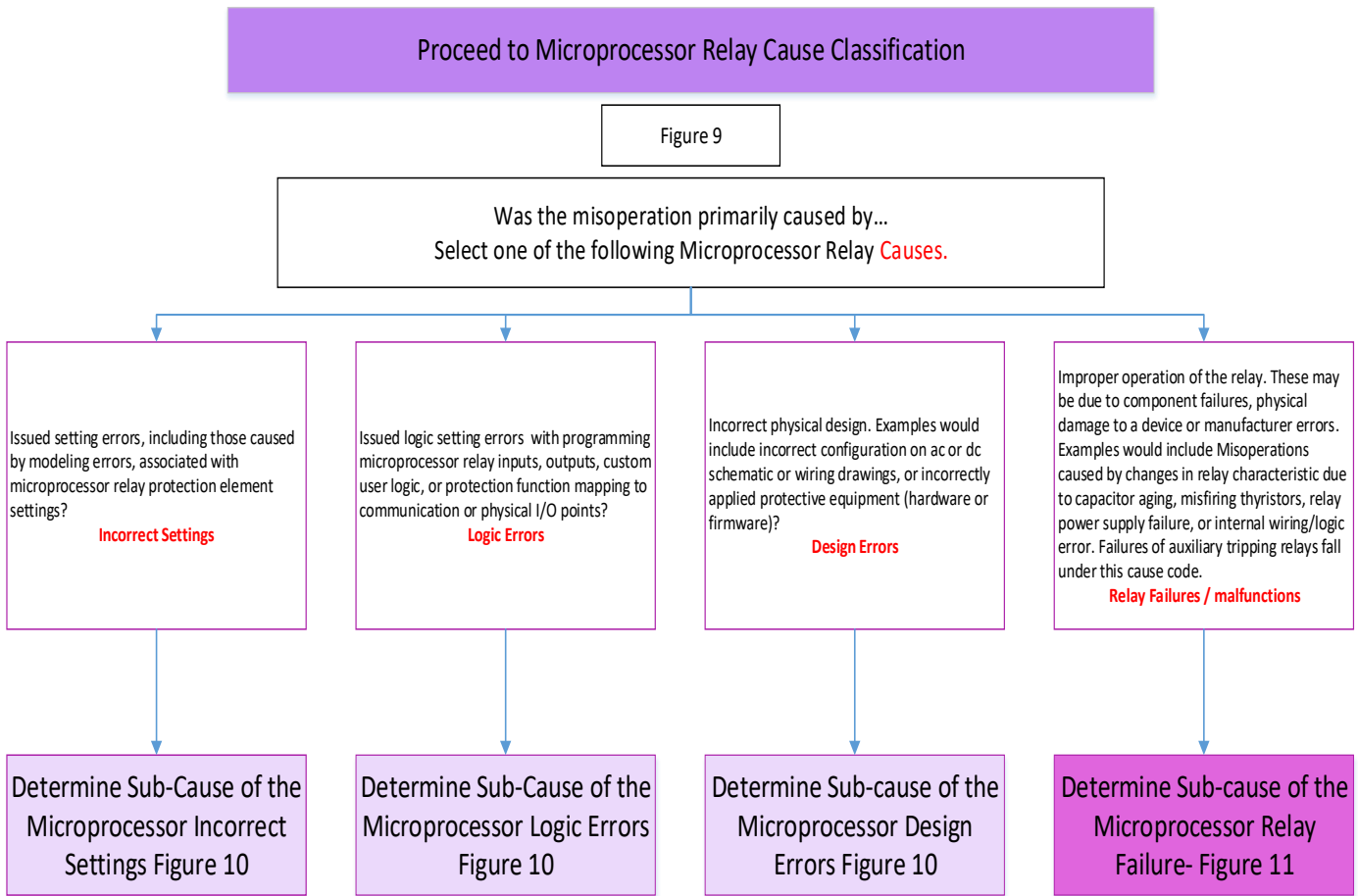

Figure H.7: Microprocessor Relay Cause Classification

Figure 10

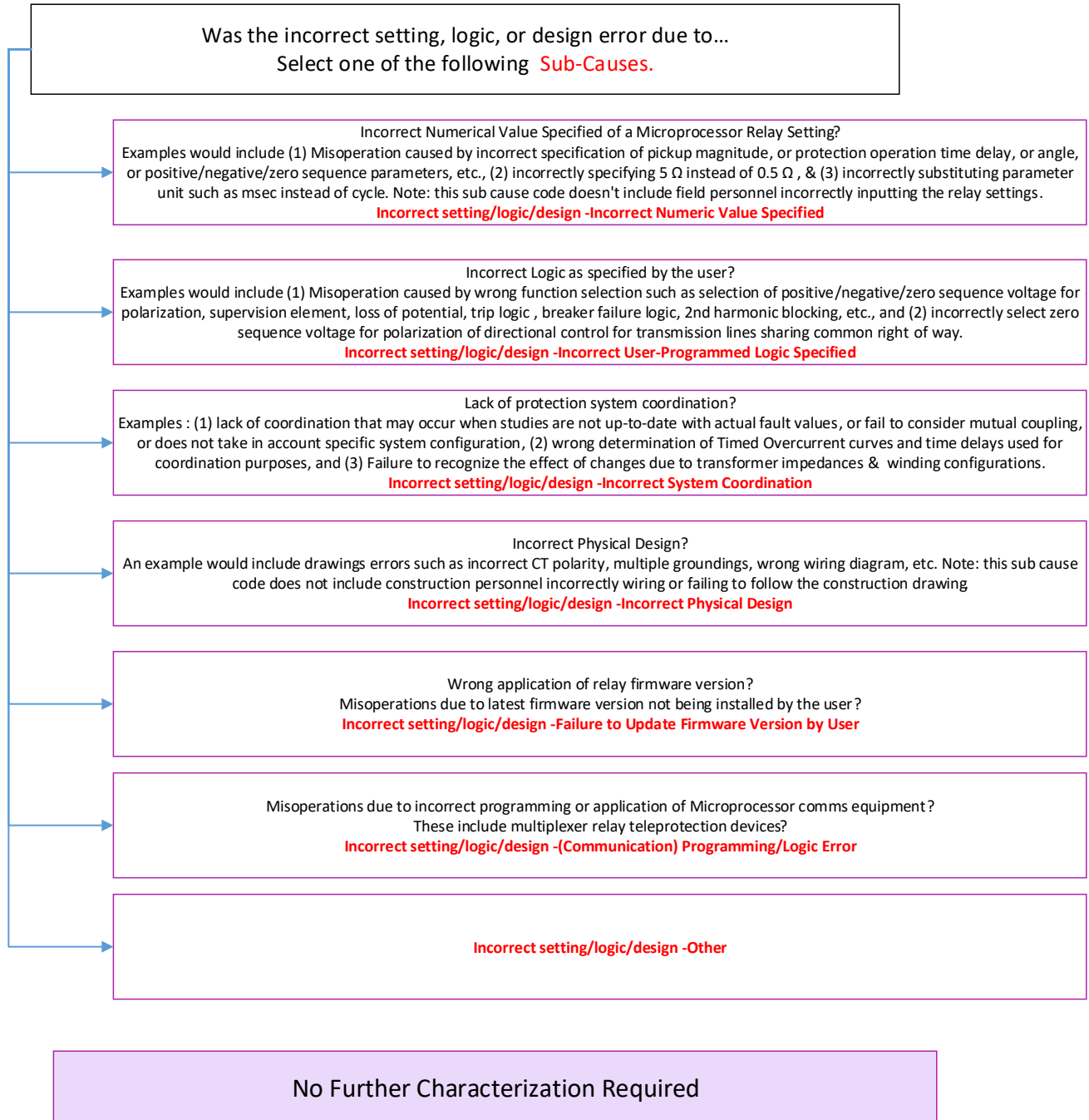

Figure H.8: Incorrect Setting, Logic, or Design Error Sub Cause

Determine the Relay Failure/Malfunction Sub Cause of the Misoperation

Figure 11



Figure H.9: Relay Failure/Malfunction Sub Cause of Misoperation