

NERC

NORTH AMERICAN ELECTRIC
RELIABILITY CORPORATION

Reliability Guideline

Methods for Establishing IROs

September 2018

RELIABILITY | ACCOUNTABILITY



3353 Peachtree Road NE
Suite 600, North Tower
Atlanta, GA 30326
404-446-2560 | www.nerc.com

Table of Contents

Preface	iv
Preamble	v
Executive Summary.....	vi
Introduction	vii
Use of Terminology in this Guideline	ix
Relevant FERC Orders and Directives	x
Principles of Defining IROLs.....	xii
BPS Operating States and System Security	xiv
Chapter 1 : Analytical Framework for Establishing IROLs	1
Process and Time Frames of Establishing IROLs.....	1
Types of Operating Limits.....	6
Operating with Proxy Limits and Real-Time Limits.....	9
Non-Consequential Load Loss in TPL Studies vs. IROL Load Loss Criterion.....	11
Operating Limit Margin and Defining IROLs.....	11
Study Assumptions and Study Criteria	15
Chapter 2 : Classification of Power System Stability.....	17
Rotor Angle Stability.....	18
Frequency Stability	21
Voltage Stability.....	23
High Frequency and Control-Related Stability	30
Chapter 3 : Recommended Practices to Assess Instability	33
Instability Impact Thresholds	34
Rotor Angle Instability Assessment Techniques.....	34
Small Signal Instability Assessment Techniques.....	47
Voltage Instability Assessment Techniques	51
Frequency Instability Assessment Techniques.....	59
Controls-Related Instability Assessment Techniques.....	63
Chapter 4 : Uncontrolled Separation Assessment Techniques.....	67
Description of Controlled Separation.....	67
Description of Uncontrolled Separation.....	67
Overview of Controlled and Uncontrolled Separation Analysis.....	68
Example Comparison of Controlled and Uncontrolled Separation	69
Chapter 5 : Cascading Analysis Assessment Techniques	74
Proposed Definition and Description of Cascading.....	74

Bounded vs. Unbounded Cascading	74
Cascading Fundamentals and Cascading Trees	75
Low Voltage Tripping as Part of Cascading Analysis.....	78
Defining an Overload Threshold for Cascading Analysis	80
Divergent Powerflow and “Soft Outage” Considerations	84
Typical Cascading Analysis Process	86
Probabilistic or Risk-Informed Cascading Analysis	89
Appendix A : FERC Orders and Directives	90
FERC Order No. 693 (Issued March 16, 2007)	90
FERC NOPR Leading to Order No. 705 in Docket RM07-3-000 (Issued August 13, 2007).....	94
FERC Order No. 705 (Issued December 27, 2007).....	94
FERC Order No. 748 (Issued March 17, 2011)	95
Order 802 (Issued November 20, 2014).....	96
FERC Remand NOPR (Dockets RM13-12-000, RM13-14-000) (Issued November 21, 2013)	96
FERC Order No. 817 (Issued November 19, 2015)	97
Appendix B : Examples of Instability Analysis	99
Example of System Voltage Instability during Contingency Analysis	99
Example of Transient Voltage Instability Analysis.....	101
Example of Unit Instability Analysis	103
Appendix C : Examples of Uncontrolled Separation Analysis	106
Alberta-British Columbia Separation Scheme	106
Appendix D : Examples of Cascading Analysis	111
Example 1a: Bounded Cascading in Local Load Pocket	111
Example 1b: Bounded Cascading in Local Load Pocket Voltage Collapse	111
Example 2: Bounded Cascading with Substation Mid-Line	112
Example 3: Load Pocket Interactions	112
Example 4: Bounded Cascading Sequence of Events	113
Example 5: Unbounded Cascading Sequence of Events.....	115
Appendix E : Using Real-Time Stability Tools for IROLs	117
Benefits of Real-Time Tools for RTAs	117
Potential Issues with Real-Time Transient Stability Analysis	117
Appendix F : M-8 Reporting by Reliability Coordinators.....	119
Appendix G : List of Acronyms	120
Appendix H : Contributors	122

Preface

The vision for the Electric Reliability Organization (ERO) Enterprise, which is comprised of the North American Electric Reliability Corporation (NERC) and the seven Regional Entities (REs), is a highly reliable and secure North American bulk power system (BPS). Our mission is to assure the effective and efficient reduction of risks to the reliability and security of the grid.

The North American BPS is divided into seven RE boundaries as shown in the map and corresponding table below. The multicolored area denotes overlap as some load-serving entities participate in one Region while associated Transmission Owners/Operators participate in another.

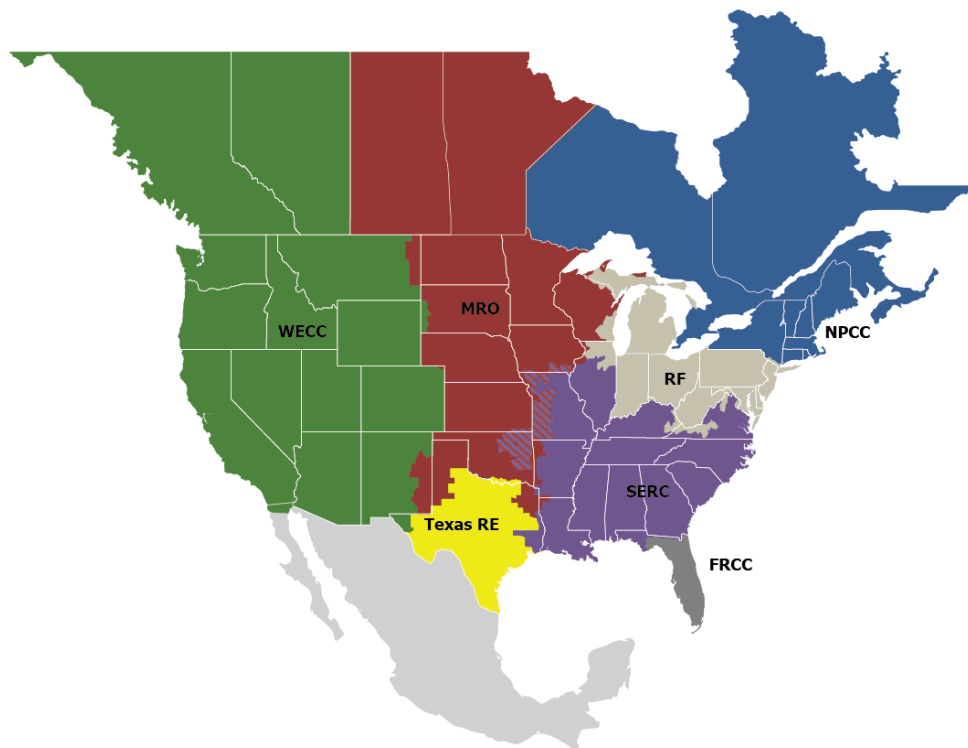

FRCC	Florida Reliability Coordinating Council
MRO	Midwest Reliability Organization
NPCC	Northeast Power Coordinating Council
RF	ReliabilityFirst
SERC	SERC Reliability Corporation
Texas RE	Texas Reliability Entity
WECC	Western Electricity Coordinating Council

Preamble

NERC, as the FERC-certified ERO¹, is responsible for the reliability of the Bulk Electric System (BES) and has a suite of tools to accomplish this responsibility, including but not limited to the following: lessons learned, reliability and security guidelines, assessments and reports, the Event Analysis program, the Compliance Monitoring and Enforcement Program, and Reliability Standards. Each entity, as registered in the NERC compliance registry, is responsible and accountable for maintaining reliability and compliance with the Reliability Standards to maintain the reliability of their portions of the BES.

It is in the public interest for NERC to develop guidelines that are useful for maintaining or enhancing the reliability of the BES. The NERC Technical Committees—the Operating Committee (OC), the Planning Committee (PC), and the Critical Infrastructure Protection Committee (CIPC)—are authorized by the NERC Board of Trustees (Board) to develop Reliability (OC and PC) and Security (CIPC) Guidelines per their charters.² These guidelines establish voluntary recommendations, considerations, and industry best practices on particular topics for use by users, owners, and operators of the BES to help assess and ensure BES reliability. These guidelines are prepared in coordination between NERC Staff and the NERC Technical Committees. As a result, these guidelines represent the collective experience, expertise, and judgment of the industry.

The objective of each reliability guideline is to distribute key practices and information on specific issues to support high levels of BES reliability. Reliability guidelines do not provide binding norms and are not subject to compliance and enforcement (unlike Reliability Standards that are monitored and subject to enforcement). Guidelines are strictly voluntary and are designed to assist in reviewing, revising, or developing individual entity practices to support reliability for the BES. Further, guidelines are not intended to take precedence over Reliability Standards, regional procedures, or regional requirements. Entities should review this guideline in conjunction with Reliability Standards and periodic review of their internal processes and procedures and make any needed changes based on their system design, configuration, and business practices.

¹ <http://www.ferc.gov/whats-new/comm-meet/072006/E-5.pdf>

² [http://www.nerc.com/comm/OC/Related%20Files%20DL/OC%20Charter%2020131011%20\(Clean\).pdf](http://www.nerc.com/comm/OC/Related%20Files%20DL/OC%20Charter%2020131011%20(Clean).pdf)
[http://www.nerc.com/comm/CIPC/Related%20Files%20DL/CIPC%20Charter%20\(2\)%20with%20BOT%20approval%20footer.pdf](http://www.nerc.com/comm/CIPC/Related%20Files%20DL/CIPC%20Charter%20(2)%20with%20BOT%20approval%20footer.pdf)
<http://www.nerc.com/comm/PC/Related%20Files%202013/PC%20Charter%20-%20Board%20Approved%20November%202013.pdf>

Executive Summary

This Reliability Guideline provides guidance³ for the utility industry to develop technically sound methods for establishing Interconnection Reliability Operating Limits (IROLs). The guideline provides detailed technical reference material related to the assessment of system instability, uncontrolled separation, and cascading to ensure Reliable Operation of the BPS. Each of the three concepts related to Reliable Operation are discussed in depth, including analysis techniques and considerations that should be made when determining how they may contribute to the establishment of an IROL. Recommended practices and techniques are described using example simulations and actual system studies to clearly articulate the concepts. The various facets of establishing IROLs are described in sufficient detail to seek consistency in terminology and analysis techniques.

IROLs are fundamentally limits rather than conditions. IROLs are a subset of System Operating Limits (SOLs) where Reliable Operation of the BES may be compromised if the limit is exceeded. While IROLs are a subset of SOLs, both serve to ensure security and stability of the BES. These limits are used for real-time operation and are generally established prior to real-time operations during off-line studies. However, advanced tools are being increasingly used to update these limits in near real-time, and those tools can be used to establish new IROLs in real-time in some cases. Establishment of SOLs and IROLs prior to real-time operation ensures reliable operation of the BES. It also ensures that operating processes and plans are developed to provide the system operators with steps to operate within SOLs (including IROLs), ensuring unforeseen operating conditions are minimized and the system is operated in a secure operating state. Each IROL has a mitigation time (IROL T_v); operators use any actions available to them, up to and including precontingency load shedding, to prevent and mitigate an exceedance. IROLs are used in the operations horizon as “operating limits” in coordination with outage coordination and other operating plans to ensure Reliable Operation of the BES. Consistent with the NERC FAC⁴ standards under development, IROLs do not necessarily need to be established in the planning horizon; however, the relationship between planning and operations performance criteria should be consistent.

This guideline was developed in tandem with other activities by the NERC Methods for Establishing IROLs Task Force (MEITF), which also proposes revised definitions for inclusion in the NERC Glossary of Terms,⁵ and an IROL framework of recommended changes to applicable NERC Reliability Standards. Those activities, along with this guideline, provide clarity to the IROL related definitions and consistency on how those definitions are applied in the NERC standards. Further, the guideline provides a technical reference from which analytical techniques used to establish IROLs can draw from. This guideline serves as a technical basis and set of recommended practices in the analysis of instability, system instability, uncontrolled separation, and cascading. It is recommended that Reliability Coordinators (RCs) developing SOL Methodologies use or adapt the techniques described in this guideline for their own studies.

The Reliability Guideline primarily applies to RCs responsible for the establishment of IROLs as well as Planning Coordinators (PCs) who may also be involved in developing the processes and analyses for determining IROLs. The concepts outlined herein also relate to the overall reliable planning and operation of the BPS and therefore are also applicable to Transmission Planners (TPs) and Transmission Operators (TOPs).

³ This guideline is an outcome of the NERC MEITF created to provide technical basis and guidance to the utility industry related to the establishment of IROLs. This effort was undertaken at the request of the NERC PC and OC to support the NERC Project 2015-09 Standard Drafting Team (SDT).

⁴ Facilities Design, Connections, and Maintenance

⁵ NERC Glossary of Terms: https://www.nerc.com/pa/Stand/Glossary%20of%20Terms/Glossary_of_Terms.pdf.

Introduction

The establishment and communication of SOLs and IROLs are addressed in NERC Reliability Standards FAC-010-3, FAC-011-3, and FAC-014-2. These standards have remained essentially unchanged since their inception. As part of NERC's periodic review process, a Periodic Review Team (PRT 2015-03) was formed in 2014 to review these Facility Designs, Connections, and Maintenance (FAC) standards and in July 2015 published its Periodic Review Recommendation (PRR) containing a series of proposals related to these standards. The PRR recommended the formation of a SDT to address the issues identified.

NERC Project 2015-09 *Establish and Communicate System Operating Limits* was formed in August 2015 in response to the PRR. The primary objective of the project is to revise the FAC standards to eliminate overlap with approved Transmission Planning (TPL) standard requirements,⁶ to enhance consistency with Transmission Operations (TOP)⁷ and Interconnection Reliability Operations (IRO)⁸ standards, and to address other concerns in the existing FAC standards regarding determination and communication of SOLs and IROLs. As outlined in the Standards Authorization Request (SAR),⁹ the scope of the project includes development of new or revised requirements and NERC Glossary definitions to provide clarity and consistency for establishing SOLs and IROLs as well as to address potential reliability issues resulting from application of the current NERC Glossary definitions for SOL and IROL.¹⁰

One of the primary issues identified in the FAC PRR is inconsistency and lack of clarity in determining IROLs. Ambiguities in the approved definition of an IROL and other related terms, in combination with those in the FAC standards, render an environment where the criteria and processes for IROL establishment can vary widely from one RC to the next. Since FAC-010-3 and FAC-011-3 do not include specific criteria or instructions for establishing IROLS, PCs and RCs have developed varying criteria or thresholds to identify when an SOL, if exceeded, would cause the types of effects that warrant an IROL designation and are therefore subject to a subset of additional requirements (e.g., the IROL T_v requirement). As a consequence, RCs and PCs are establishing IROLs using different methods and criteria, and there are differing opinions regarding when and how an IROL should be differentiated from an SOL, particularly with respect to identifying when an exceedance of an SOL would result in instability necessitating an IROL designation.

Specifically, the PRR acknowledged that the use of the word "instability" in the IROL definition is particularly problematic as this term can be interpreted to include any and every instance of instability that spans the entire spectrum of consequences and severity of impact—ranging from one extreme where instability results in the loss of a single small unit to the other extreme where instability results in widespread outage of a major portion of an RC area or beyond. The PRR contended that localized, contained instances of instability that affect a small amount of load have little to no impact on the reliability of the BES and do not warrant IROL establishment.

In FERC Order No. 817, the Commission sought comment on identification of all regional differences or variances in the formulation of IROLs, the potential reliability impacts of such differences or variations, and the value of providing a uniform approach or methodology to defining and identifying IROLs. In this order, FERC accepted NERC's recommendation that NERC Project 2015-09 would address the clarity and consistency of the requirements for establishing both SOLs and IROLs.

The FAC SDT polled RCs in North America and confirmed the existence of differences in the formulation of IROLs. However, the SDT revealed some degree of consistency as well in the criteria used to determine IROLs. The SDT

⁶ See, TPL-001-4

⁷ See, TOP-001-3, TOP-002-4, TOP-003-3

⁸ See, IRO-001-4, IRO-002-4, IRO-008-2, IRO-010-2, IRO-014-3, IRO-017-1

⁹ http://www.nerc.com/pa/Stand/Project%20201509%20Establish%20and%20Communicate%20System%20Op/2015-09_SOL_Standard%20Authorization%20Request.pdf.

¹⁰ The SAR was sponsored and submitted by the [Project 2015-03 -Periodic Review of System Operating Limit Standards](#) PRT

incorporated these similarities in their proposed revisions to the IROL related requirements in FAC-011-3. In May 2016, the SDT held a technical conference where industry indicated support for crafting requirements in FAC-011 that allow the RC to exercise some degree of judgment and have an appropriate amount of flexibility with regard to establishing IROLs for its RC Area. In an effort to strike a balance between strict uniformity and total flexibility, the FAC SDT drafted IROL related requirements that allowed for an appropriate amount of exercise of engineering judgment but identified the criteria the RCs must consider in exercising that judgment. This approach was reflected in the draft FAC-011 Requirement R6 posted for informal comment in July 2016. The proposed requirement directed the RC to include in its SOL Methodology the method and criteria for establishing IROLs and required the criteria to describe the severity and extent of reliability impact that warrants establishment of an IROL, including the following:

- Unacceptable quantity of load loss due to instability, cascading outages, or uncontrolled separation
- Unacceptable quantity of supply loss due to instability, cascading outages, or uncontrolled separation
- Unacceptable thresholds for inter-area oscillations (including acceptable damping criteria and criteria for inter-area oscillations versus intra-area oscillations)
- Unacceptable impacts on neighboring Reliability Coordinator Areas within an Interconnection

While industry comments (received from the informal posting) were by and large supportive of the IROL-related requirements proposed in the draft FAC-011, FERC staff voiced significant concerns that proposed Requirement R6 was a “fill-in-the-blank” requirement, that it conflicted with the statutory definition of Reliable Operation,¹¹ and that it proposed to allow qualifiers to instability, cascading, and uncontrolled separation that FERC staff deemed unacceptable. FERC staff voiced concern for allowing instability of any kind and to any degree in real-time operations.

One of the challenges the FAC SDT faced in the development of the IROL-related standards was the absence of industry-vetted technical documentation on the subject of IROLs, IROL establishment, and the three aspects of the approved IROL definition—instability, cascading, and uncontrolled separation. Because IROLs are a critical component to reliable planning and operation of the BPS, and due to the highly technical nature of the analysis and studies, the SDT believed it would be beneficial for industry experts to develop technical material related to the methodologies used to establish IROLs. This technical material could then be used to inform the development of IROL-related requirements. At the urging of the SDT, the NERC Standards Committee (SC) requested technical assistance from the NERC OC and PC to do the following:

1. Assess the impact that instabilities can have on BPS reliability
2. Describe simulation methods for assessment of instability, including appropriate methods for use in quantifying impact the instability and available means for demonstrating impact containment
3. Identify technically sound methodologies for use in establishing IROLs to address different types of instabilities
4. Evaluate the reliability impacts, if any, resulting from use of different methods to establish IROLs across North America

Specifically, the SC requested the formation of a joint task force (comprised of both planners and operators) to develop technical material that could be used as an industry reference to enhance the manner in which IROLs are established and also by the SDT (or other future standard drafting team addressing the IROL issue) as a technical basis for revisions to related Reliability Standards. The NERC OC and PC agreed to this request and formed the MEITF. This task force served as the author of this document.

¹¹ <https://www.ferc.gov/industries/electric/indus-act/section-1211.pdf>

Use of Terminology in this Guideline

The NERC MEITF is proposing modifications and addition of terms to the NERC Glossary of Terms related to the establishment of IROLs. The terms proposed by NERC MEITF, shown in **Table I.1**, are intended to bring clarity and consistency to the NERC Reliability Standards. These terms are used throughout this guideline, and should be interpreted in this document using the definitions shown in **Table I.1**. The guideline uses minimal capitalization so as not to confuse terms with the NERC Glossary definitions. Note that the terms in **Table I.1** are proposed by the NERC MEITF; however, they are not approved definitions.

Table I.1: Proposed Glossary Definitions Associated with IROLs

Term	Definition
Interconnection Reliability Operating Limit (IROL)	A System Operating Limit that, if exceeded, could lead to System Instability, Uncontrolled Separation, or Cascading that adversely impact the reliability of the Bulk Electric System.
IROL T_v	The maximum time that an Interconnection Reliability Operating Limit can be exceeded. Each Interconnection Reliability Operating Limit's T_v shall be less than or equal to 30 minutes.
Stability	The ability of Elements of the Bulk Power System, for a given initial operating condition, to regain a state of operating equilibrium after being subjected to a Disturbance.
System Stability	The ability of the Bulk Power System,* for a given initial operating condition, to regain a state of operating equilibrium after being subjected to a Disturbance. *Refers to the remaining portion of the interconnected Bulk Power System, with the exception of the Elements disconnected as a result of the Disturbance.
Instability	The inability of Elements of the Bulk Power System, for a given initial operating condition, to regain a state of operating equilibrium after being subjected to a Disturbance.
System instability	The inability of the Bulk Power System,* for a given initial operating condition, to regain a state of operating equilibrium after being subjected to a Disturbance. *Refers to the remaining portion of the interconnected Bulk Power System, with the exception of the Elements disconnected as a result of the Disturbance.
Controlled Separation	The intended islanding of a portion of the Bulk Power System that includes generation or load.
Uncontrolled Separation	The unintended islanding of a portion of the Bulk Power System that includes generation or load.
Cascading	The uncontrolled successive loss of Bulk Power System Elements triggered by a Disturbance.

Relevant FERC Orders and Directives

To provide additional background on how IROL related NERC Reliability Standards were developed, this section provides short synopses of relevant FERC Orders related to IROLs and short summaries of related activities around those Orders. [Appendix A](#) provides specific paragraphs within the orders that discuss IROL related topics. Note that the Commission speaks through its orders and that each order should be read in its entirety to obtain the appropriate context of a particular order.

FERC Order No. 693 (Issued March 16, 2007)¹²

FERC Order No. 693 approved 83 of 107 proposed Reliability Standards, six of the eight proposed regional differences, and the NERC Glossary of Terms Used in Reliability Standards developed by NERC. It also directed NERC to submit significant improvements to 56 of the 83 Reliability Standards that were approved. Several aspects of this order addressed the importance of the timeliness of operator action to maintain system reliability. Specifically, the order requires that immediate action be taken to mitigate IROL exceedances, and in no case should those actions take longer than 30 minutes. Load shedding may be required to address IROL exceedances within the IROL T_v and should be used as a measure of last resort. The order also addressed concerns that the Transmission Loading Relief (TLR) Procedure is not an effective means of mitigating IROL exceedances because its implementation typically takes longer than 30 minutes. However, the TLR Procedure could be used to avoid IROL exceedances going forward after the initial IROL exceedance has been mitigated via corresponding operating plans.

FERC NOPR Leading to Order No. 705 in Docket RM07-3-000 (Issued August 13, 2007)¹³

This NOPR led to the approval of FAC-010-1, FAC-011-1, and FAC-014-1 (becoming Order No. 705), proposing to accept the currently effective IROL and IROL T_v definitions, under the notion that these definitions are consistent with the statutory definition of Reliable Operation. However, FERC noted concern with the portion of the IROL definition that states “that adversely impact the reliability of the bulk electric system,” meaning that any IROL violation adversely impacts the reliability of the BES. FERC also clarified that the only acceptable time to exceed an IROL is the limited time after a contingency has occurred, and operators are taking action to mitigate the exceedance of the limit.

FERC Order No. 705 (Issued December 27, 2007)¹⁴

FERC Order No. 705 approved the initial versions of the FAC standards related to SOLs and IROLs (FAC-010-1, FAC-011-1, and FAC-014-1), requiring “planning authorities and [RCs] to establish methodologies to determine system operating limits for the [BPS] in the planning and operation horizons.” The order remanded the proposed definition of cascading outages due to its open-ended nature, stating that the phrase “a predetermined area” that excludes the phrase “by studies” could be interpreted to refer to a scope as small as the elements that would be removed from service by local protective relays to as large as the entire BA footprint. FERC’s concern was that the pre-determined area could be based on considerations other than engineering criteria. Additionally, the order accepted the currently effective definitions of IROL and IROL T_v . However, FERC expressed concern with the phrase “that adversely impact the reliability of the [BES]” as was stated in the corresponding NOPR. The order also explains FERC’s position that the Violation Risk Factor associated with the communication of IROLs in FAC-014-1 warrants a “high” designation due to the criticality of having situational awareness of IROLs. FERC cited that ineffective communication was a contributing factor in the August 2003 blackout and other major blackout events.

¹² Mandatory Reliability Standards for the Bulk-Power System, FERC Order No. 693, Docket No. RM06-16-000, 16 March 2007. Available: <http://www.ferc.gov/whats-new/comm-meet/2007/031507/E-13.pdf>.

¹³ Facilities, Design, Connections and Maintenance Mandatory Reliability Standards, Notice of Proposed Rulemaking, 72 FR 160 (Aug. 20, 2007), FERC Stats. And Regs. ¶ 32,622 (Aug. 13, 2007). Available: <http://www.ferc.gov/CalendarFiles/20070813182314-RM07-3-000.pdf>.

¹⁴ Facilities Design, Connections and Maintenance Reliability Standards, FERC Order No. 705, Docket No. RM07-3-000, 27 Dec 2007. Available: <http://www.ferc.gov/whats-new/comm-meet/2007/122007/E-3.pdf>.

FERC Order No. 748 (Issued March 17, 2011)¹⁵

FERC Order No. 748 “approve[d] three new Interconnection Reliability Operations and Coordination Reliability Standards...The [standards] were designed to prevent instability, uncontrolled separation, or cascading outages that adversely impact the reliability of the interconnection by ensuring that the [RC] has the data necessary to assess its [RC] area during the operating horizon and that it takes prompt action to prevent or mitigate instances of exceeding [IROLs].” The order supports clear distinction of primary responsibility for SOLs and IROLs between the TOP and RC, respectively. While TOPs are primarily responsible for SOLs and RCs are primarily responsible for IROLs, the order clarifies that there may be “grid-impactive” SOLs that warrant closer attention by the RC.

In the order, FERC states that “SOLs could become IROLs” and this has been a point of confusion in the industry since the term “SOL” in earlier FERC Orders was misused interchangeably with the concept of “SOL exceedance”. It is generally understood that the intent behind the notion that “SOLs could become IROLs” is that exceeding an SOL could escalate into an operating condition where the next worst contingency event could result in instability, cascading, or uncontrolled separation. Much of the content of FERC Order No. 748 has been superseded or otherwise clarified in subsequent FERC orders (the FERC Remand NOPR and FERC Order No. 817).

Order 802 (Issued November 20, 2014)¹⁶

Though FERC Order No. 802 was issued to approve CIP-014-1, the IROL-related paragraphs are relevant to the interpretation and application of IROLs and related concepts. In this order, FERC directs NERC to remove, or otherwise address FERC’s concerns with the term “widespread” in Requirement R1 of CIP-014-1. FERC determined that the term is unclear and subject to interpretation. Despite this FERC Order, the term “widespread” currently still exists in the FERC-approved definition of cascading.

FERC Remand NOPR (Dockets RM13-12-000, RM13-14-000) (Issued November 21, 2013)¹⁷

This NOPR resulted in a remand of the relevant TOP and IRO standards, and NERC withdrew the petition in January 2014, noting it would work on the topic and propose updated changes in 2015. The Reliability Standards addressed by the Remand NOPR proposed to require TOPs to operate within those SOLs that “support reliability internal to its area identified as a result of its [Operational Planning Analysis] (OPA).” The main point behind the Remand NOPR was to convey FERC’s position that all SOLs, not just certain SOLs, need to be operated within their respective limit. Additionally, FERC contended that given the dynamic nature of the system, SOL exceedances that were not identified in the OPA could occur in real-time operations. Thus, highlighting the importance of addressing all SOLs as opposed to only those identified in the OPA as supporting reliability within the TOP area. As was mentioned in FERC Order No. 748, FERC reiterated their concern that “SOLs can rapidly degrade into an IROL” While the terms are not used appropriately, the concept that the operating conditions can quickly change as a sequence of unexpected events occurs is warranted. FERC mentioned that both the 2003 blackout and 2011 blackout events were initiated by non-IROL SOL exceedances.

FERC Order No. 817 (Issued November 19, 2015)¹⁸

FERC Order No. 817 approved revisions to the TOP and IRO standards and directed modification to the standards. The TOP and IRO standards that were approved in FERC Order No. 817 work together in a manner consistent with the statutory definition of Reliable Operation and also convey the notion that managing SOL exceedances is a shared responsibility between the TOP and the RC. They also render an environment where the operating plan is the ultimate

¹⁵ Mandatory Reliability Standards for Interconnection Reliability Operating Limits, FERC Order No. 748, Docket No. RM10-15-000, 17 March 2011. Available: <http://www.ferc.gov/whats-new/comm-meet/2011/031711/E-8.pdf>.

¹⁶ Physical Security Reliability Standard, FERC Order No. 802, Docket No. RM14-15-000, 20 November 2014. Available: <http://www.ferc.gov/whats-new/comm-meet/2014/112014/E-4.pdf>.

¹⁷ Monitoring System Conditions – Transmission Operations Reliability Standard, Transmission Operations Reliability Standards, Interconnection Reliability Operations and Coordination Reliability Standards, Notice of Proposed Rulemaking, 18 CFR Part 40 (Nov. 21, 2013), FERC Stats. and Regs ¶ 61,158. Available: <https://ferc.gov/whats-new/comm-meet/2013/112113/E-3.pdf>.

¹⁸ Transmission Operations Reliability Standards and Interconnection Reliability Operations and Coordination Reliability Standards, FERC Order No. 817, Docket No RM15-16-000, 19 November 2015. Available: <http://www.ferc.gov/whats-new/comm-meet/2015/111915/E-10.pdf>.

mechanism for addressing SOL/IROL exceedances within the necessary operating time frames. The requirements set forth in these standards, along with the revised definitions of OPA and Real-Time Assessment (RTA), develop the following workflow:

1. TOPs and RCs perform OPAs to identify potential SOL/IROL exceedances
2. TOPs and RCs develop and communicate operating plans to address SOL/IROL exceedances identified in OPAs
3. TOPs and RCs perform RTAs at least once every 30 minutes
4. TOPs and RCs implement operating plans to address SOL/IROL exceedances identified in real-time monitoring and RTAs

FERC accepted NERC's recommendation that NERC Project 2015-09 would address the clarity and consistency of the requirements for establishing SOLs and IROLs. The NERC Methods for Establishing IROLs Task Force (MEITF) was formed to develop technical materials to be used as a resource for the Project 2015-09 SDT (or future SDT that develops revisions related to IROL establishment) to support their obligation in evaluating revisions to the existing standards with regard to the establishment of IROLs.

Principles of Defining IROLs

IROLs have been in existence since the inception of FAC-010-1, FAC-011-1, and FAC-014-1, and the inclusion of IROL in the NERC Glossary of Terms. Since its inception, the application of IROL has been up to the interpretation of each RC (and varied widely between RCs). This document intends to provide clarity and consistency in establishing IROLs for use in real-time operations. The establishment of IROLs stands on fundamental principles that should be considered throughout the discussion of establishing IROLs:

- **An IROL is a limit, not a condition:** The IROL term is often erroneously used to represent a condition. It is sometimes implied that "instability is an IROL" or "cascading is an IROL." System instability, cascading, or uncontrolled separation are outcomes of a contingency and/or operating condition, not an IROL themselves. An IROL is a limit put in place to prevent system instability, cascading, and uncontrolled separation from occurring.
- **IROLs address an elevated risk to BES reliability:** IROLs are intended to address system instability, uncontrolled separation, or cascading that impact Reliable Operation of the BES.
- **IROLs are a subset of SOLs, and both IROLs and SOLs coexist:** The system is operated within SOLs (and IROLs) to ensure Reliable Operation of the BES. Some SOLs are designated as IROLs based on their impact to BES reliability. IROLs are a subset of SOLs established to prevent the broader, more adverse, reliability impacts to the BES. Operating within both SOLs and IROLs is required for Reliable Operation¹⁹ of the BES. Operation within SOLs and IROLs, as required by the NERC Reliability Standards, is also a critical aspect of achieving what NERC defines as an Adequate Level of Reliability.²⁰ A given interface, load pocket, etc. may have multiple SOLs (e.g., thermal-based) as well as one or more IROLs (e.g., instability, or cascading conditions). These interaction/existence of both SOLs and IROLs is dependent upon the conditions that exist when the operating limit is exceeded.

¹⁹ **Reliable Operation:** Operating the elements of the [Bulk-Power System] within equipment and electric system thermal, voltage, and stability limits so that instability, uncontrolled separation, or cascading failures of such system will not occur as a result of a sudden disturbance, including a cybersecurity incident or unanticipated failure of system elements.

²⁰ **Adequate Level of Reliability:** ALR is the state that the design, planning, and operation of the Bulk Electric System (BES) will achieve when the listed Reliability Performance Objectives are met. Further, Reliability Assessment Objectives included in the definition must be evaluated to assess reliability risk in support of an adequate level of reliability. Available:

http://www.nerc.com/comm/Other/Adequate%20Level%20of%20Reliability%20Task%20Force%20%20ALRTF%20DL/Final%20Documents%20Posted%20for%20Stakeholders%20and%20Board%20of%20Trustee%20Review/2013_03_26_ALR_Definition_clean.pdf

- **Either an SOL or IROL can be the more restrictive operating limit:** All SOLs, and the subset of SOLs designated as IROLs, are derived based on the same criteria. Depending on real-time conditions, system characteristics, and other factors, the most restrictive operating limit could be either an SOL or an IROL. System operating conditions, for example, could be limited by a facility rating or a system voltage limit (e.g., SOLs) or could be limited by a potential system instability condition where an SOL may become an IROL to mitigate those consequences. In some cases, SOLs may become IROLs based on the impending operating conditions.
- **If an IROL is less limiting than other SOLs, studies and engineering judgment should be used to identify where the IROL exists:** Even if there is an SOL that is the more limiting constraint for system operations, reasonable engineering judgment and studies should be used to identify if there is another less limiting SOL that may need to be designated as an IROL. For example, the more limiting SOL is a thermal limit while the less limiting SOL (that may be an IROL) is a voltage stability based limit. If the less limiting SOL (that may be an IROL) is only slightly beyond the point of the more limiting SOL exceedance, it should be well studied and understood prior to real-time operations. On the other hand, if the potential less limiting IROL requires significant stressing of system conditions such that they are unrealistic then it may not need to be studied since these conditions are very unlikely to occur. In either case, the less limiting SOL and more limiting IROL exist; however, the RC (based on its SOL Methodology) may or may not establish an IROL based on its likelihood of occurring.
- **IROLs are generally established prior to real-time operation during off-line studies:** Typically, the risk of system instability, uncontrolled separation, or cascading is identified through off-line studies that determine the need to establish an IROL. These studies (to establish an IROL) typically occur in the operations planning horizon, in OPAs, or long-term planning studies. Once an IROL has been established (i.e., the constraint as well as the limit), the IROL limit can be updated either through off-line studies (e.g., OPA) or during near real-time (e.g., RTA) as applicable. In some cases, the RC may establish an IROL in near real-time if the situation and tools enable the creation of an IROL that quickly.
- **Real-time tools may refine or update IROL limits:** Real-time tools enable the ability to update established IROL limits in near real-time based on impending system conditions. This provides a determination of the IROL limit that is more representative for the impending system conditions compared to off-line studies. However, these tools may have limited capabilities for analyzing certain types of instability. Also, not all RCs have real-time tools to calculate IROLs in near real-time. Therefore, based on the current state of technology, it is important that requirements related to establishing IROLs are clear and applicable to both off-line studies and near real-time tools.
- **When unforeseen operating conditions are encountered, focus should be on returning to a secure operating state and not on establishing an IROL in real-time:** Unforeseen operation conditions can, and do, occur in real-time operations (e.g., unexpected contingency events, generation outages, abnormal load patterns). Although unlikely, the RTA could indicate that the next contingency could result in system instability, uncontrolled separation, or cascading. In this scenario, system operators should be focusing on returning the system to a studied and secure operating state with a sense of urgency—similar to an exceedance of an IROL (e.g., any necessary actions within 30 minutes). Mitigation steps should exhaust all options, which may include load shedding if necessary, to return to an operating state that will not result in system instability, uncontrolled separation, or cascading if the critical contingency were to occur. Once a secure and stable operating condition has been attained, the conditions should be analyzed after-the-fact to determine if an IROL should be established moving forward (i.e., these conditions could potentially occur in the near-term or longer-term operating conditions²¹). These concepts apply to unforeseen conditions but not to expected or planned conditions. If proxy limits that are established off-line are the only limits available to

²¹ For example, multiple equipment failures occurred simultaneously, which could require multiple days or weeks to replace and return the outages elements to service.

the RC (not updated by RTA), then N-1-1 conditions should be studied to be prepared for establishing limits if the next contingency were to occur.

- How Operating Plans for SOLs²² are developed may affect the frequency and duration of any potential IROL exceedances:** How non-IROL SOLs are operated to (e.g., time duration an SOL can be exceeded) and the actions taken to address any SOL exceedances have a direct relation with the frequency and duration of any potential IROL exceedances. Operating within a SOL using real-time tools may minimize the potential of an IROL being exceeded. Similarly, if the capability exists to update IROLs in near real-time, conservative limits pre-determined in off-line studies can be adjusted accordingly. Use of real-time tools and execution of operating plans to mitigate SOL exceedances in a timely manner can help reduce the likelihood of reaching an IROL.
- IROLs have a mitigation time (T_v) and may require actions to prevent or mitigate an exceedance up to and including pre-contingency load shedding:** The potential consequences of exceeding an IROL are significantly more severe than the potential consequences of exceeding an SOL. An IROL carries with it a required mitigation time, the IROL T_v , which can be no longer than 30 minutes.²³ When an IROL is exceeded, the system must be returned to within the IROL within the IROL T_v . This includes any necessary action by the RC, including precontingency load shedding. On the other hand, any SOL exceedance identified in the OPA must have an associated operating plan; however, SOLs do not necessarily have to have a specified time element (only an operating plan in place) nor require the use of pre-contingency load shedding within a specified time frame.²⁴
- IROLs should be established in coordination with other activities:** Mitigating actions for a potential SOL or IROL exceedance depends on the time frame of the analysis. Establishing IROLs should be considered in concert with scheduling and approving maintenance outages and is one option for ensuring reliable operation. Some entities may establish IROLs and take the planned maintenance outage while others may deny the outage and reschedule it to avoid establishing an IROL (based on the credibility of the IROL limit being reached in the outage conditions relative to the SOL). In the end, the avoidance of the operating state that could have an adverse impact on BES reliability is attained. The RC coordinates activities in its footprint (with neighboring RCs and its TOPs) to ensure reliable operation, establishing IROLs as one of many mitigating actions for impending system conditions.

BPS Operating States and System Security

BPS security can be described as the ability to reliably withstand sudden disturbances (e.g., electric short circuits or unanticipated loss of system components).²⁵ Fink and Carlsen²⁶ proposed a framework for grid security forty years ago, which fundamentally still holds today with slight adaptation and changes in terminology to reflect the current RC operating practices. This framework is described here to provide high-level context to more detailed aspects of establishing IROLs (and SOLs) throughout this guideline.

The BPS can be described as operating in one of the following states (see [Figure I.1](#)):

- Normal (N-k Secure):** all operating constraints (including stability limits) are met in the precontingency (N-0) operating state and the system is also able to withstand a set of credible (N-k) contingencies.

²² While IROLs are a subset of SOLs, this guideline often refers to SOLs to mean those SOLs that are not IROLs and explicitly calls out IROLs for clarity. However, the reader should use judgment and review the definitions for SOLs and IROLs to avoid any confusion.

²³ The T_v mitigation time is determined by the RC based on the severity and risk of the potential instability, uncontrolled separation, and cascading. Typically the T_v is 30 mins although it may be lower. In rare cases (i.e., small signal instability for pre-contingency, normal operating conditions), the T_v could feasibly be zero to prevent the system condition from occurring entirely. While feasible, this is a relatively rare situation and stated here only for comprehensiveness.

²⁴ Although this may be part of individual RC and TOP operating plans.

²⁵ See the definition of "Adequate Level of Reliability":

[http://www.nerc.com/pa/Stand/Resources/Documents/Adequate_Level_of_Reliability_Definition_\(Informational_Filing\).pdf](http://www.nerc.com/pa/Stand/Resources/Documents/Adequate_Level_of_Reliability_Definition_(Informational_Filing).pdf)

²⁶ Adapted from L. H. Fink and K. Carlsen, "Operating under Stress and Strain," *IEEE Spectrum*, March 1978, pp. 48-53.

- **Alert (N-k Insecure):** the system is not operating within all SOLs (for both the pre-contingency and studied postcontingency operating state). Preventive actions are taken to return the system to a *Normal* operating state.
- **Emergency (N-k Unstable):** the system is not operating within all IROLs, and therefore system stability, uncontrolled separation, or cascading may occur if the critical contingency were to occur. Prompt corrective actions are taken to mitigate the IROL exceedance (and potentially any SOL exceedance(s)).
- **Extreme (N-0 Unstable):** the system is in a severe operating state either pre-contingency or immediately following a contingency with exceedances of IROLs (and possibly SOLs), and is experiencing system instability, uncontrolled separation, or cascading. Any possible operator actions are taken to maintain the integrity and continuity of serving generation and load.
- **System Restoration:**²⁷ significant parts of the system have lost synchronism, potential islanding, widespread cascading outages, or uncontrolled separation have occurred. System restoration actions are needed to return to a *Normal (Secure)* state (possibly transitioning through an *Alert (Insecure)* state in the process).

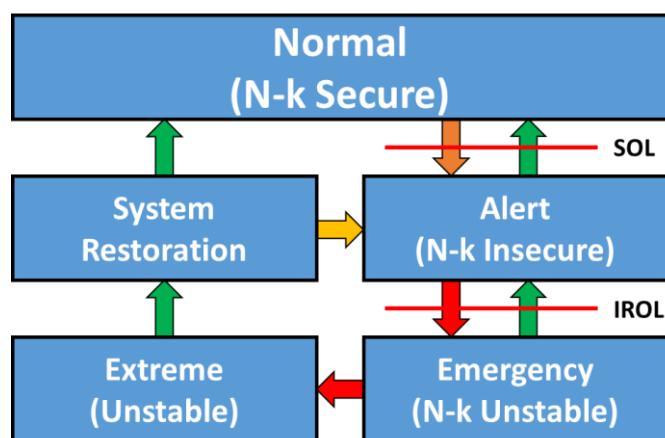

Figure I.1: Power System Operating States

[Source: Adapted from Fink and Carlsen]

The BPS operating in the *Normal* state is often referred to as *Secure*—ready to withstand a set of credible (*N-k*) contingencies without exceeding applicable emergency ratings: this is the expected operating condition of the BPS at all times, considering planned and maintenance outages, scheduling, security constraints, etc. OPAs and Real-Time Analyses (RTAs) are performed to ensure the system operates within these constraints for expected system conditions. These analyses include *security assessments* (e.g., real-time contingency analysis (RTCA), stability analysis) of the operating state.

However, the BPS may enter the *Alert* state where a possible contingency would result in violating the postcontingency operating limits. Operating plans are

developed to reduce the likelihood of these occurrence and to return the system to a *Normal* state. The *Emergency* state is rarely reached during real-time operation; however, conditions may occur where the IROL is exceeded and the system could potentially exhibit system instability, uncontrolled separation, or cascading if the critical contingencies were to occur. Unplanned or unexpected events may cause the system to enter into this state and prompt action (within the IROL T_v) is taken to return the system to the *Normal* state.

²⁷ System restoration, including blackstart, is outside the scope of this report and not covered in detail here. However, the secure, insecure, and emergency conditions are critical to the discussion of establishing SOLs and IROLs.

Stability limits (either SOLs or IROLs) are an important aspect of operating in the *Normal*, *Alert*, and *Emergency* states. Some non-IROL stability limits prevent localized stability that has minimal impact on the overall BPS. SOLs (and operating plans) help mitigate the system being operated in a state where these issues could cause the system to enter into the *Alert* or *Emergency* state; however, these localized stability issues would not cause the system to enter the *Extreme (Unstable)* state if the critical contingency were to occur. Conversely, IROLs are established to ensure that corrective actions are taken in a timely manner to mitigate the exceedance of an IROL (i.e., entering the *Emergency* state). Ideally, the system will be returned to the *Normal* state and possibly passing through the *Alert* state (also returning below any SOLs that are exceeded). Once SOL and IROL constraints (and associated T_v limit) are established, the TOP and RC can manage the operating state more effectively during real-time operation.

Key Takeaway:

IROLS are established to ensure that corrective actions are taken to prevent and mitigate the exceedance of limits to either return to the *Normal* state or stay within the *Alert* state for certain conditions and contingencies that could otherwise cause the BPS to enter the *Extreme* state, being at high risk of system instability, cascading, and uncontrolled separation.

Chapter 1: Analytical Framework for Establishing IROLs

This chapter describes the overall analytical framework, process, and time frames in which IROLs are established. The framework described here provides a holistic structure for understanding the various complex aspects of IROLs. However, this chapter does not describe what exactly constitutes an IROL since that is dependent on the NERC Reliability Standards requirements.

Process and Time Frames of Establishing IROLs

IROLs should be established prior to real-time operation and those limits should be operated within to ensure Reliable Operation of the BES. [Figure 1.1](#) describes a general process of establishing IROLs and managing the operating state within the IROL during real-time operations. Studies to establish potential IROLs include developing a base case that represents the expected pre-contingency operating state(s), and analysis of the post-contingency operating state(s) to identify conditions that result in system instability, uncontrolled separation, or cascading. The IROL is fundamentally a limit (i.e., a numerical value)—in practice, it consists of two components:²⁸

- **Constraint:** The set of limiting system elements that are monitored to manage the risk of system instability, cascading, and uncontrolled separation.
- **Limit:** The limiting value of the constraint to ensure that system instability, cascading, and uncontrolled separation do not occur if the critical contingency(ies) were to occur.

Once the constraint (set of system elements) and limit (value associated with the constraint) have been established by studies, the TOP and RC manage the operating state to within the IROL during real-time operation. This creates a feedback loop and is illustrated in the right-half loop of [Figure 1.1](#). When unexpected or unplanned operating conditions are encountered, the focus of the system operator is returning to a studied and secure operating state with a sense of urgency. This sense of urgency, which should include any and all available operator actions up to and including load shedding, should return the system to an operating state that does not pose a potential risk for system instability, uncontrolled separation, or cascading (ideally within 30 minutes). Operating plans should be in place to address these types of situations that may be encountered, although rare. Once a safe operating state is reached and the system is within established IROLs, after-the-fact analysis should explore if an IROL should be established for future real-time conditions. If so, then the IROL constraint and limit are determined, established, and operated within for future real-time operations. In some instances, an RTA may be able to execute a study quick enough to determine if the operating state is acceptable. This process is captured in the left-half loop of [Figure 1.1](#).

²⁸ This concept also applies to non-IROL SOLs.

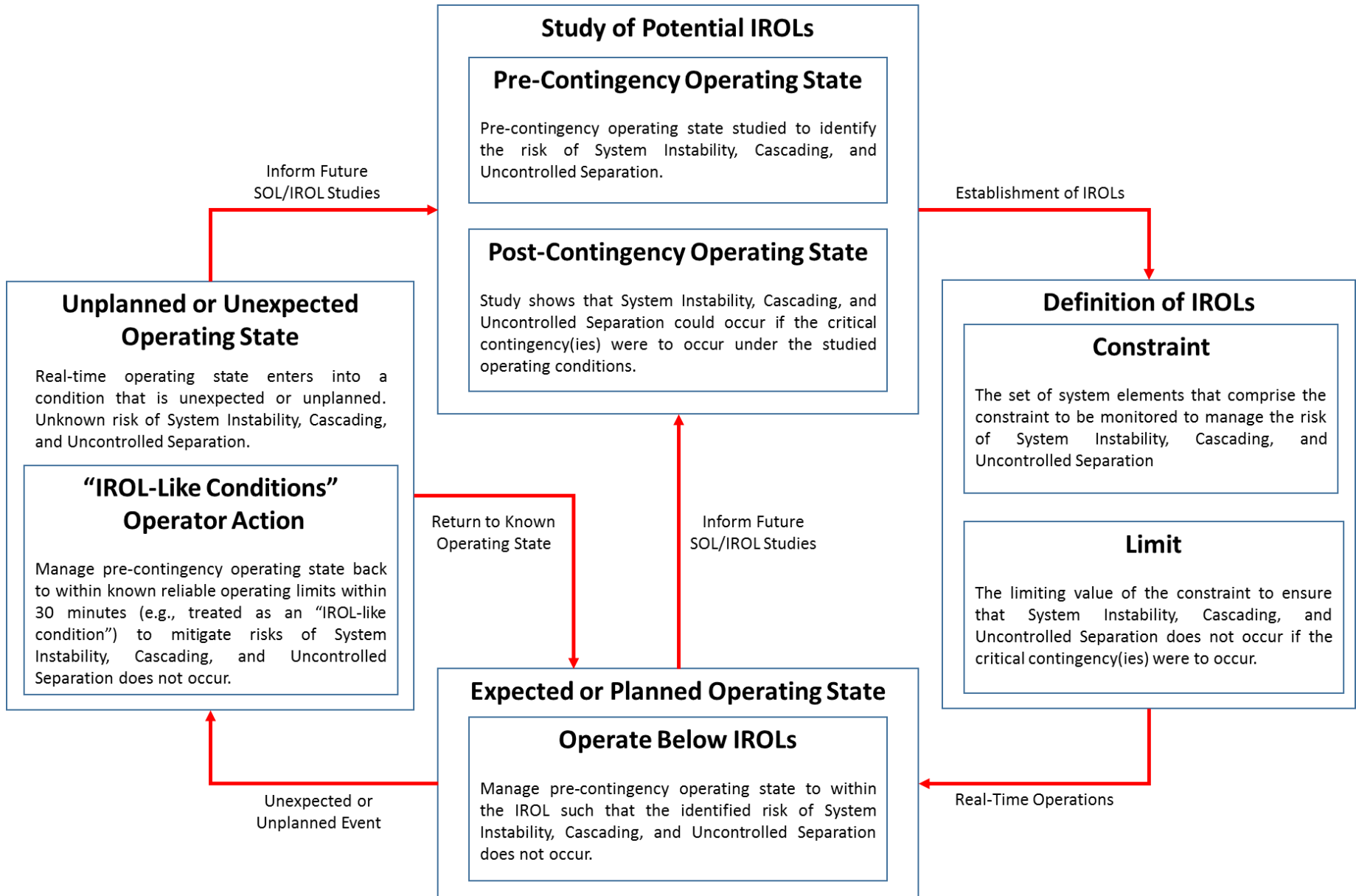

Figure 1.1: General Process of Establishing IROs Prior to Real-Time Operation

Study Time Frames

IROLs (and other SOLs) may be established across a range of time frames as illustrated in [Figure 1.2](#). The time frames conventionally²⁹ used for establishing these limits include the following:

- Long-Term Planning (one to 10 years out):** TPs provide input to the RC as an outcome of their Planning Assessments on any potential system limitations, stability limits, and critical contingencies that should be considered in the operations horizon. The RC uses this information during the actual establishment (and updating) of IROLs. More detailed studies are performed by the RC to establish SOLs and IROLs as real-time approaches. System performance criteria in the operations time frame should be similar to that in the long-term planning horizon. However, the RC deals with varying system demand levels, forced outage conditions, planned outages, and other factors that may deviate from maintenance schedules set months earlier. Information should flow to the RC to help inform them of critical information for their assessments; this concept is being proposed by the Project 2015-09 SDT for revisions to FAC-011.
- Operations Planning (day-ahead to one year out):** In the Operations Planning horizon, transmission and generation outages are scheduled, more accurate load forecasts are available, and the impending system conditions can be more accurately studied. Expected generation dispatches and system topologies can be used to identify any operating states or critical contingency(ies) that could result in system instability, cascading, and uncontrolled separation. In these cases, a new IROL can be determined or a pre-determined IROL can be updated using the more accurate modeling and study assumptions.
- Next-Day Operational Planning Analysis³⁰ (one day to two days out):** In the next-day horizon, the RC studies expected system conditions (e.g., generation dispatch, transmission outages, load forecasts, system topology, approved tags) to determine appropriate operating plans for the next day. The next day OPA should identify any potential conditions that could lead to system instability, uncontrolled separation, or cascading, establish any IROLs (that may not be previously identified (if applicable), and update existing IROLs (if applicable). These studies may not always be able to reconfirm the established IROLs limits based (depending on the type of study), and therefore the established IROL should be reviewed to ensure that it sufficiently covers for the impending system conditions.
- Intra-Day Analysis (one hour to 24 hours out):** New IROLs are typically not established past the Next-Day horizon although existing IROLs may be updated intra-day as system conditions change. If there is a significant deviation from the next-day OPA (e.g., due to significant topology changes, generation redispatch), existing IROLs may be reassessed (or new IROLs may be established) to ensure Reliable Operation of the BES.
- Near Real-time (< one hour):** New IROLs are typically not established during real-time operation although existing IROLs may be updated in near real-time. Some entities use real-time tools (e.g., on-line voltage stability analysis (VSA) or transient stability analysis (TSA)) that enable automatic updates to IROLs (and other stability limits) once the studies have completed (hence the phrase “near real-time”). The real-time tools ideally result in IROLs that more accurately reflect the actual IROL for that given operating state (rather than a predetermined/pre-studied IROL based on off-line studies). Regardless of the use of real-time tools, system operators ensure the system is operated within the established IROLs (either predetermined or updated in near real-time) and only exceeded for less than the T_v time limit. In real-time operation, system operators are focused on ensuring SOLs and IROLs are respected and the system remains in a reliable operating state and not focused on whether the specific real-time system conditions warrant establishing an IROL. As described above, unexpected system conditions experienced in real-time can be used to inform future off-line studies to determine if a new IROL should be established.

²⁹ The exact time frames for each category may differ slightly between entities based on internal practices.

³⁰ NERC Reliability Standard IRO-008-2 and the NERC Glossary define Operational Planning Analysis starting from next-day operations. This guideline further elaborates on this, without changing any of these fundamental definitions, by also describing next-day OPA. This aligns well with RC study procedures.

A limit derived in a study horizon further away from real-time operation should be more conservative (based on study assumptions) than any real-time limits computed (See section on “Study Assumptions and Study Criteria” below.) For example, an IROL identified in the Long-Term Planning or even Operations Planning horizon should use conservative assumptions that may provide more restrictive limits and study results than IROL studies performed in the Next-Day Analysis environment or using near real-time tools.

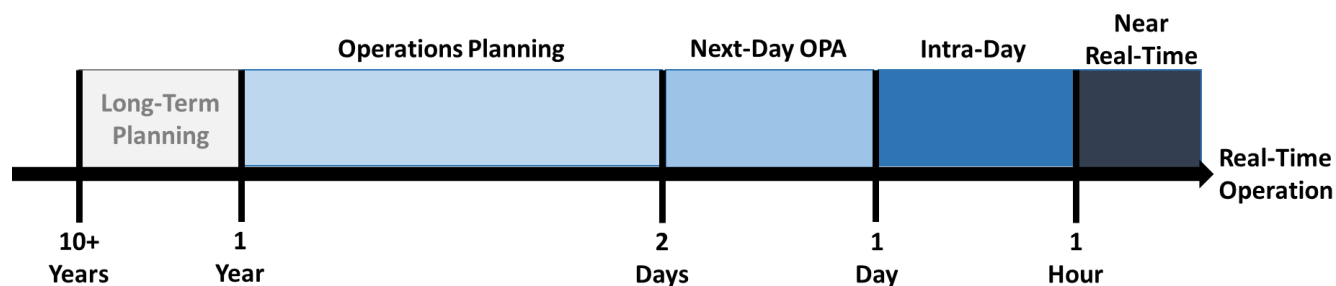

Figure 1.2: Range of Study Time Frames for Establishing IROLs

Study Assumptions and Identifying Boundary Conditions

Studies that establish IROLs are based on a set of assumptions with engineering judgment. Along with any operating limit margin applied to the established IROL, study assumptions also act as a “margin” since they often lead to a limit lower than the actual IROL to ensure Reliable Operation in the real-time operating horizon. Examples of study assumptions include the following:

- Demand Level:** The load forecast used in the study may not always reflect the actual demand level encountered in real-time operation. If the system is only studied to the predicted load forecast, the analysis may not identify the need for an IROL. Higher or lower than expected load forecasts may be used to account for any load forecast error. It may be prudent to analyze the system considering a historical load forecast error to capture potential IROL conditions that could be past the current predicted load.
- Generation Dispatch:** Fuel prices, amount of rainfall, regulatory constraints, weather patterns, etc., can change quite drastically between the implicit assumptions in the study that determine the generation dispatch and the actual system conditions in real-time operation. Unanticipated generation patterns have the potential to have a significant impact on the stability of the overall system. By considering all realistic conditions, including both heavy and lightly loaded generation patterns as indicative of the most realistic operating conditions in which system instability may arise, the studies can ensure that these less frequently experienced conditions have been evaluated to ensure Reliable Operation.
- High Transfers and/or Loop Flows:** It can be difficult to predict the amount of power flows that could be impacting an area during real-time operations. Non-firm transmission service, loop flows, and market flows aren’t normally built into long-term planning or operations planning models due to the difficulty in predicting the magnitude and direction of the flows. If study cases are not adequately stressed to account for these flows, an operator could find the system in a state that was not studied adequately in order to determine if there are conditions that could lead to system instability, uncontrolled separation, or cascading.
- Facility Outages:** The potential for system instability, uncontrolled separation, or cascading increases when facilities are out of service—such as for planned maintenance or forced out due to weather events. It is important to ensure the system remains in a stable state even during conditions where there are a significant number of facilities out of service. In addition, some facilities may have de-ratings during maintenance or other activities that could increase the risk of cascading.
- Load Model Sensitivity:** Stability in studies can largely be impacted by the load model used when conducting the study. A different ratio of load types can push an otherwise stable scenario to an unstable scenario. When

analyzing the system for potential system instability, uncontrolled separation, or cascading, it is important to accurately represent the load with a realistic load characteristic.

Studies to establish IROLs should have clearly documented methods for creating stressing patterns and boundary conditions to identify if an IROL exists under the most conservative (stressed) yet plausible operating conditions. Often times, there may be a SOL that should be treated as an IROL yet would only be identified under stressed system conditions beyond the point of historic operating conditions.

In addition, there may be additional SOLs that should be treated as IROLs that would only be identified if the system were operated beyond the point of SOL exceedance.³¹ If the system is to be operated past the identified limiting SOL, studies should be performed to determine if any additional SOLs exist and whether an IROL should be established. Studying only up to the point of SOL exceedance (or only slightly past the SOL exceedance) is not sufficient.

The RC should use engineering judgment to create boundary cases and stressing patterns (similar to those used in TPL-001-4) to reach those boundaries using different sensitivities. Sensitivities may include the following:

- Generation dispatch (e.g., high wind, constrained gas supply, drought conditions)
- Load forecast (i.e., higher or lower than expected load level)
- Source-sink transfer combinations (different generation/load elements in source and sink to modify stress direction)
- Facility outages (planned maintenance or forced)
- Load model sensitivities
- Planning contingency event categories (e.g., including N-2)

The assumptions used for off-line studies to establish IROLs (and some non-IROL SOLs) may be more conservative than those used in near real-time tools since the off-line studies may not reflect actual operating conditions as closely. Regardless of how and when the studies are performed, the system should be stressed sufficiently to have a high confidence that the conditions experienced in real-time have been analyzed for potential conditions that could lead to system instability, uncontrolled separation, or cascading.

Contingency Event Selection

NERC TPL-001-4 details categories of contingencies and performance requirements within the Long-Term Planning horizon to ensure that the BPS will reliably operate over a broad spectrum of system conditions under a wide range of contingencies. Critical contingencies, among other information, from these assessments should be provided to the RC for further analysis in the establishment of potential IROLs. OPAs generally do not include such a comprehensive set of contingencies³² due to the limited time for analysis but may include higher levels of prior outage analysis (N-1-x).³³ In shorter-term horizons, it is not feasible to include all of the contingency event studies that are conducted in the Long-Term Planning horizon. However, contingencies beyond N-1 that have a higher likelihood of occurrence³⁴

³¹ For example, there may be an N-1 thermal SOL that would normally limit transfer. But under stressed conditions, an operating plan might be put in place that would allow operation beyond the SOL because of available post-contingency actions. In such cases, there may be an additional SOL which is an IROL due to a different phenomenon (e.g. voltage collapse).

³² OPAs may not include the full comprehensive set of contingencies that the long-term planning horizon focuses on; however, they should the credible multiple contingencies as described in the SOL Methodology.

³³ N refers to the number of elements in service. For planning studies, this may include all elements in service. However, in OPAs, outage coordination studies, and other operations horizon studies, N may refer to a pre-contingency operating condition with multiple elements already out of service (before the studied contingency is simulated).

³⁴ For example, based on historical experience. The NERC Reliability Standards set the minimum required contingencies to be studied; however, the RC may include additional credible multiple contingencies to ensure reliable operation of the BES.

or a higher risk of leading to system instability, uncontrolled separation, or cascading, should be addressed in the SOL Methodology as part of the contingency set.

Continuity of Performance Criteria

NERC TPL-001-4 describes steady-state and dynamic performance requirements in the Long-Term Planning Horizon. When this performance criteria is not met, Corrective Action Plans are developed to address identified shortcomings—transmission reinforcements, capital investments, updated controls, new technologies, etc. To ensure consistency between the planning and operations horizons, performance criteria should match, to the extent possible, for establishing SOLs and IROLs. As real-time approaches, the studies are often updated to modifying the potential SOL or IROL limits; however, the performance criteria should remain the same.

Types of Operating Limits

The establishment of SOLs and IROLs is predicated on determining appropriate security criteria from which SOLs are derived. An SOL is defined as the value (e.g., MW, MVAR, Amperes, Frequency, or Volts) that satisfies the most limiting of the prescribed operating criteria for a specified system configuration. This section describes how the limits in the operating criteria are developed and provided to the RC.

Facility Ratings

NERC Reliability Standard FAC-008-3 Facility Ratings requires determination of both normal and emergency facility ratings by TOs and GOs. In the pre- and post-contingency state, facilities should be operated within their thermal and equipment Normal (continuous) and Emergency (short-term) Ratings. These ratings have an associated time duration in which they can be reliably operated at that limit. The establishment of operating plan should clearly articulate the necessary time in which action needs to be taken to return to within these ratings. This is particularly important when developing a methodology for cascading analysis (discussed later in this guideline). **Figure 1.3**³⁵ illustrates the application of facility ratings to SOL performance. Other limits may be used, such as a continuous rating, an eight hour rating, 30 minute rating, etc., depending on utility practices. When operating at or below the specified facility rating within the specified time duration, facilities should not trip out-of-service due to failure caused by loading. Facility ratings may change (lower or higher) based on maintenance work, construction, etc.

PRC-023-4 also requires that transmission line relays be set such that they do not operate at or below 150 percent of the highest seasonal facility rating for the loading duration nearest four hours, at or below 115 percent of the highest seasonal 15-minute facility rating or other criteria specified in Requirement R1.³⁶ Essentially, protective relays should not trip facilities out-of-service so long as power flow remains within the relay loadability criteria.

In the event that post-contingency flows exceed or are expected to exceed Emergency Ratings, there is a limited time (if the contingency were to occur) before equipment will fail, line clearances will be violated, or relay action may trip facilities. However, operating plans may permit post-contingency flows above Emergency Rating in lieu of pre-contingency load shedding so long as the post-contingency SOL exceedance(s) do not result in cascading (i.e., the exceedance can be mitigated within the relevant amount of time). For an RC to allow operation of a facility with post-contingency flows above 100 percent of the highest emergency rating for any amount of time, prior coordination and verification from the equipment owner (e.g., TO or GO) is necessary. If the operating plan permits these conditions, the RC should have the necessary tools to identify when the SOL exceedance would result in cascading and quickly mitigate flows within 30 minutes (T_v). An IROL should be established if the SOL exceedance results in cascading.

³⁵ The 2014-03 SDT developed a white paper titled “System Operating Limit Definition and Exceedance Clarification”, available here: http://www.nerc.com/pa/Stand/Prjct201403RvsnstoTOPandIROStndrds/2014_03_fifth_posting_white_paper_sol_exceedance_20150108_cl_ean.pdf.

³⁶ Refer to PRC-023-4 for more details.

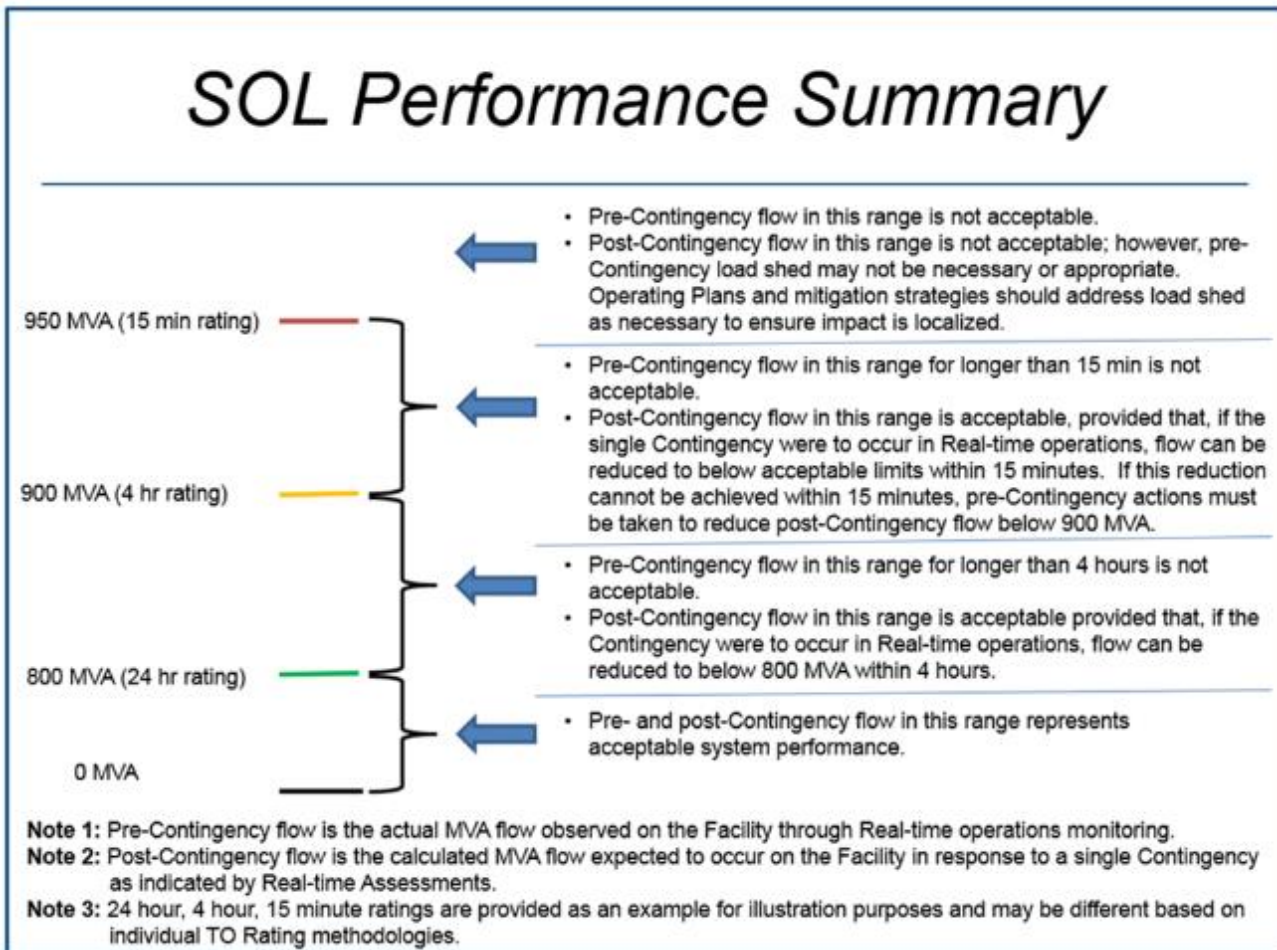

Figure 1.3: SOL Performance Coordinated with Facility Ratings Example

System Voltage Limits

Acceptable system voltage limits are based on equipment voltage ratings (e.g., accounting for equipment facility ratings) and steady-state system voltage considerations. Equipment voltage ratings are specified by the TO or GO as part of their Facility Ratings Methodology, per FAC-008-3. System voltage limits are established to respect those equipment voltage ratings and also to ensure adequate voltages across the system. In the pre-contingency normal operating state, voltages are held to within currently specified values (target, or high and low tolerance range) and may be modified from time to time based on season, operating conditions, etc. In the post-contingency operating state, voltages should remain within emergency system voltage limits. SOL exceedances occur when actual bus voltage is outside Normal limits or when the RTA indicates that bus voltage would fall outside applicable Emergency limits following a contingency and could not be corrected by the system operator before equipment damage occurs after the contingency.

Transient Stability Limits

Transient stability limits are based on a specified set of stability criteria that should be described in the SOL Methodology. These limits can take many forms. However, the limits should be established in a manner that easily translates to monitored parameters that are observable and actionable by system operators. The objective of a transient stability limit is to ensure that the stability criterion is adequate to prevent transient instability or unacceptable transient response if the critical contingencies were to occur. Often, establishing a transient stability limit is accomplished by using a proxy flow limit (MW flow across a particular transmission interface,³⁷ cutplane,

³⁷ A transmission interface is a group of transmission elements representing a connection between parts of an interconnection.

flowgate, or nomogram), a proxy generation output limit (e.g., the summation of power output from multiple units), reactive power output, or other form of monitored element(s). For example, the IROL may be defined as the total power flow across three key transmission circuits (i.e., a transmission interface), and the system would be operated to within that IROL precontingency to avoid system instability if the critical contingency were to occur.

The establishment of a transient stability limit typically occurs during off-line studies due to the complexity, computation time, and analysis of results. However, in some situations these limits can be updated or adjusted as the impending system conditions change using results from OPAs or if near real-time stability tools are available from an RTA.

Frequency Stability Limits

Frequency stability limits are typically based on a set of criteria that should be described in the SOL Methodology, if applicable. The criteria typically involves under- or over-frequency threshold based on performance requirements for that Interconnection. For example, under-frequency stability limits may use the first stage of under-frequency load shedding (UFLS) as a proxy for frequency instability to avoid triggering load shedding for credible contingencies. Similar to transient stability limits, the actual limits applied may include MW output from a critical generating facility that is causing the risk for UFLS operation, minimum levels of system inertia (for low inertia systems), or other nomograms.

The establishment of frequency stability limits typically occurs during off-line studies due to the complexity, computation time, and analysis of results. However, these limits can be updated or adjusted as the impending system conditions change using results from the OPA or RTA.

Voltage Stability Limits

Voltage stability limits typically use a proxy limit, such as the maximum generation output, power transfer across a transmission interface, load level, or minimum reactive reserves that ensures voltage stability criteria are met. There are various voltage stability phenomena and assessments that can be used to determine an IROL or SOL, which will be discussed later in this guideline. The type of instability, system characteristics, etc., will determine how the voltage stability IROL is defined. Similar to transient stability, the complex nature of voltage instability often drives the use of proxy limits. These limits are established during off-line studies due to the complexity, computation time, and analysis of results. Limits may be updated or adjusted as the impending system conditions change using results from the OPA or RTA. On-line voltage stability tools (e.g., on-line VSA) are particularly useful when the instability phenomenon is well understood. Then the tool can be run very quickly to assess unexpected transfers, operating states, and outage conditions.

Examples of voltage stability limits include the following:

- A steady-state voltage stability (P-V analysis) limit, either with or without operating limit margin, defined as the summation of MW flows across an interface used in the study
- A transient voltage stability limit defined as the power output level of a critical generator during certain grid conditions to ensure sufficient reactive reserve
- A power transfer level to ensure transient voltage stability is maintained for specific critical contingencies that result in large transient power transfers

Voltage instability events that warrant establishment of an IROL are typically not contained to one or two buses. Typically many buses are impacted—wide-area power transfers (steady-state), severe voltage dips during transients (transient voltage collapse), and collective degradation of voltage over time (mid-term voltage collapse). In these cases, a proxy limit to restrict operating conditions to within known bounds (e.g., power transfers, generation output) provides a pragmatic and effective limit to establish an IROL.

Oftentimes with voltage stability analysis, particularly P-V analysis, a system voltage limit will be reached prior to reaching the instability point. For IROL purposes, studies should not stop at the system voltage limit and should continue the stressing pattern to determine the point of instability as well. This can determine where the SOL exceedance will likely occur and where the IROL would be established. Engineering judgment is applied to determine to what extent stressing should occur. If the IROL is not reached within a reasonable range past the point of SOL exceedance (e.g., excessive dispatch of source and sink gen/load values), one can determine that the IROL will not be established for these conditions. In other situations, the IROL may occur relatively close to the point of SOL exceedance (or possibly with a more restricting limit) and should be well understood and established.

It can be common in some systems to reach a maximum realistic stress pattern where additional generation is unavailable to stress the interface further. In these cases, such as PV source-sink configuration, it is not realistic to stress the network past realistically available generation patterns. If the IROL is at or near this realistic dispatch, it may be warranted to stress the system slightly beyond this available condition only for the purposes of additional engineering understanding.

Operating with Proxy Limits and Real-Time Limits

The NERC TOP/IRO Standards align with the practice that SOLs and IROLs are studied and established ahead of real-time operation. The OPA anticipates potential pre- and post-contingency conditions for next-day operations. SOLs and IROLs can be updated or established, and procedures and operating plans are prepared to address potential exceedances in real-time. The operating plans for IROLs use all options available to the system operator, up to and including pre-contingency load shedding, to prevent exceeding the IROL, and to return to within the IROL within the Tv.

For instability conditions, an SOL or IROL is often established based on a proxy limit, which is a set of operating conditions (e.g., flows on a transmission interface, power output from one or more generating units) that define a limit. These are often used due to the complexity of instability analysis and all the various factors associated with potential instability conditions. Off-line studies identify the instability conditions in great detail when establishing an IROL, and the actual limit values may be updated in near real-time using RTAs, if applicable. However, many RTAs focus on the evaluation of facility ratings, system voltage limits, etc., (i.e., using post-contingency load flows), which could result in a refinement of IROL(s). However, it may not be practical to re-assess a stability-based proxy limit in real-time.³⁸ In these cases, stability-related limits (often proxy limits) should be established ahead of real-time operation, the RTA should evaluate if these limits are being exceeded, and operating plans and procedures should be in place to effectively maintain Reliable Operation.

The limits established using off-line studies are based on assumptions, often include operating limit margin (see “Operating Limit Margin and Defining IROLs” section below), and study a wide range of potential operating conditions due to the uncertainties presented during real-time operation (as described in previous sections). These assumptions and studies should cover a wide range of possible conditions within a reasonable study effort. Anticipated conditions, planned outages, and operational experience all feed into the OPA, which is identifying operating condition and ensuring that a valid stability limit (SOL or IROL) has been established. While the system is operated securely for the next contingency, proxy limits should be established for additional layers of contingencies in the event that the contingency does occur. Then, the new stability limit will be known post-contingency otherwise the system is then being operated in a state where accurate stability limits are not well understood or established.

To illustrate this concept, **Figure 1.4** shows an example system with N elements in service (upper left). Two outages are planned (planned N-2 system) and studied prior to real-time operation (upper right). The next worst contingency is identified (note that the worst contingency is different as system topology changes) as the orange outaged line.

³⁸ Although advanced stability tools are available and applicable to some types of instability assessment, and are effectively used by system operators today.

According to the SOL Methodology, the valid SOLs, IROLs, and operating plans are established to meet the facility ratings, system voltage limits, and stability constraints for the given topology and expected system conditions. In this example, a proxy stability limit is established on the interface based on the off-line studies. Thermal constraints are evaluated using real-time tools for both OPAs and RTAs. Thus, the limits in place ensure that the system is secure and stable for the next contingency.

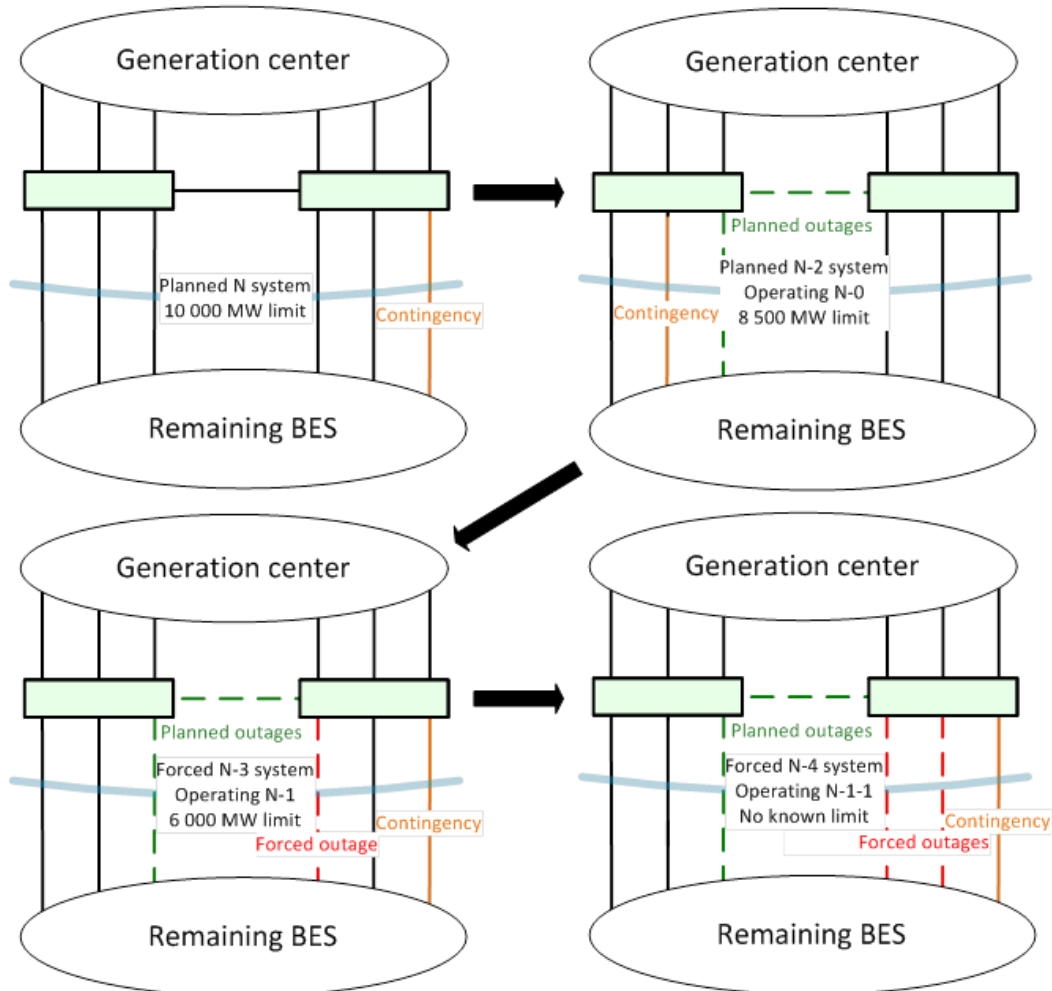

Figure 1.4: Status of System Limits for Various System Configurations

However, it is recommended to study situations where the contingency does occur during operation (forced outage) to establish limits for those potential conditions occurring and to have operating plans in place to assess the system conditions quickly and return to a studied, secure operating state within the applicable time (this could be an IROL T_v). In the example, limits have been established ahead of time to ensure knowledge of the system state after the first forced outage (i.e., to prepare for the next contingency) (bottom left in Figure 1.4). If a second forced outage were to occur (bottom right), the RTA would still be adequate to evaluate operating within facility ratings (i.e., thermal limits) for the next contingency, but no stability limits would be available to the system operator for this system configuration that may be prone to instability. Without a studied stability limit, the operator has little information on the potential for instability, uncontrolled separation, or cascading, if a contingency were to occur. Therefore, the RC should minimize the occurrence of these types of conditions by determining SOL/IROL values for post-contingency conditions for stability-related SOLs and IROLs.

Key Takeaways

For a given operating condition, the RC should either have a calculated stability limit based on proxy values from off-line studies performed ahead of real-time, or appropriate on-line tools to assess system stability and any risks of SOL/IROL exceedance. An Operating Plan should be in place to mitigate risks of entering into a system condition that is not studied prior to real-time operation. These plans may include a methodology to determine conservative and temporary limits, system reconfiguration, curtailing schedules, generation redispatch, and load shedding.

In the absence of performing real-time stability studies, procedures should be put in place to minimize the risk of occurrence of an “unknown operating state.” These conditions pose unacceptable risks of instability since the operator does not know whether the next contingency will result in system instability. These conditions should be mitigated, namely by the following:

- Performing studies to allow SOL/IROL calculations to consider planned outages and potential forced outages (minimum N-1) for the set of relevant contingencies, given system conditions and possible mitigation actions
- Providing the operator with an adequate set of proxy values for limits that cannot be properly evaluated in real-time (i.e., prepare for N-1-1 with adequate limits or operating procedures)
- Having an Operating Plan to address potential SOL/IROL exceedances and potentially credible system configurations without known limits
- Having a procedure to return to a secure state with known limits and to address unforeseen conditions based on the experience and knowledge of the system

Non-Consequential Load Loss in TPL Studies vs. IROL Load Loss Criterion

Non-Consequential Load Loss in Table 1 of TPL-001-4 is used as one of several corrective actions available to the PC or TP to meet performance requirements for P1–P7 Planning Event Contingencies. Non-Consequential Load Loss and Consequential Load Loss are defined in the NERC Glossary:

- **Non-Consequential Load Loss:** Non-Interruptible Load loss that does not include the following: Consequential Load Loss, the response of voltage sensitive Load, or Load that is disconnected from the System by end-user equipment.
- **Consequential Load Loss:** All Load that is no longer served by the Transmission system as a result of Transmission Facilities being removed from service by a Protection System operation designed to isolate the fault.

Non-Consequential Load Loss is intentionally invoked to mitigate a performance violation and is planned ahead of time. The application and differentiation of Non-Consequential vs. Consequential Load Loss is applicable to TPL assessments; however, it is not applicable to requirements specified in the SOL Methodology related to instability, uncontrolled separation, or cascading. Load loss for these types of events (other than planned actions, such as RAS) are uncontrolled or unintended and should be mitigated by establishing an IROL and executing operating plans.

Operating Limit Margin and Defining IROLs

The preceding discussion uses the term “margin,” which refers to the margin applied to operating limits; however, this term is not defined in the NERC Glossary of Terms. The Operating limit margin applied to SOLs can be defined as follows:

- **Operating Limit Margin:** a value or range applied to a System Operating Limit

An SOL (or IROL) is a limit that is provided to, and monitored by, the operator such that appropriate action can be taken to return the system to within the SOL or IROL within a predetermined amount of time based on the operating plan. Operating directly up to the SOL (or IROL) may not provide the operator with sufficient flexibility and time to take corrective action to alleviate an exceedance. Therefore, an operating limit margin may be applied to provide this capability. It may be deemed a reliability risk to operate up to the point of system instability, uncontrolled separation, or cascading for credible contingencies, and therefore an operating limit margin is applied to ensure corrective action is taken prior to surpassing the limit.

The industry has adopted various conventions for establishing IROLs (refer to [Appendix F](#)). While each RC can establish its own methodology and associated naming conventions for establishing IROLs, this has created confusion in the industry when discussing IROLs, the establishment of IROLs, and operating plans for managing system conditions within IROLs. To address this potential source of confusion, the NERC MEITF developed a consistent naming convention for discussing IROLs. This provides a common platform for RCs, in coordination with their stakeholders, to establish IROLs and ensure transparency and understanding on what the limits being derived, established, and put into operation mean.

Figure 1.5 illustrates different ways in which IROLs may be established, and how these different IROLs generally relate to one another. The Actual IROL should be the highest limit, reflecting the actual point of system instability, uncontrolled separation, or cascading (if the critical contingency were to occur) for the given system conditions encountered in real-time. The Real-Time IROL (No Margin) and Predetermined IROL (No Margin) should be relatively close to each other, with the predetermined limit slightly more conservative. The Real-Time IROL (No Margin) should also be close to the actual IROL for most cases. The Real-Time IROL (with Margin) and Predetermined IROL (with Margin) are some value less than their respective unmarginated values. Operating alarms may exist below these limits to mitigate or minimize the exceedance of any of these limits.

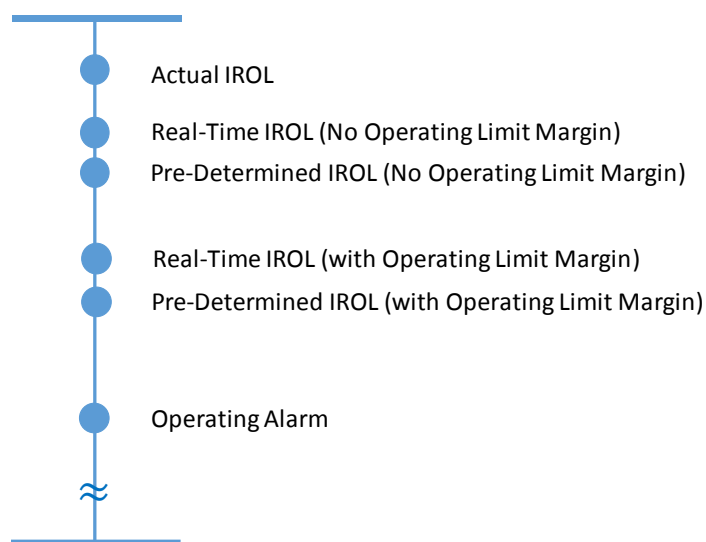

Figure 1.5: Visualization of IROL Terminology

The following definitions describe each of these types of established IROLs:

- **Predetermined IROL (No Margin):** This is a predetermined IROL, studied one or more days prior to real-time that is provided to the system operator. Not accounting for margin, this marks the studied limit in which exceedance of this limit would result in system instability, uncontrolled separation, or cascading if the initiating contingency were to occur. Entities are required to identify this as an IROL pursuant to the definition of IROL (i.e., operating limit that will cause widespread/interconnection reliability risks if exceeded and the critical contingency were to occur).
- **Predetermined IROL (with Margin):** This limit includes an operating limit margin to keep the system from being operated too close to the Predetermined IROL (No Margin). Operating limit margin is often used as a conservative approach to account for uncertainties and differences between studied conditions and the impending conditions faced in real-time. Entities may or may not identify this as an IROL based on their own operating practices.
 - Some entities treat the predetermined IROL with margin as the operating IROL, and their system operators are expected to take action within the respective T_v to get below this limit. Other entities may

define predetermined IROL with margin as an SOL and have operating plans to mitigate exceeding this limit; however, these plans will generally not include shedding load pre-contingency. In the case of defining the margined IROL as a SOL, a higher IROL should be well understood and documented to account for the Predetermined IROL (No Margin) that has a respective T_v since the defined SOL does not have this time component associated with it.

- **Real-Time IROL (No Margin):** This is the IROL determined in near real-time and provided to the system operator. Not accounting for margin, this marks the studied limit in which exceedance of this limit would result in system instability, uncontrolled separation, or cascading if the critical contingency were to occur. Since this IROL calculated near real-time does not include a margin and is using the most up-to-date system conditions to derive the limit, it should closely reflect the actual IROL for those conditions. This IROL derived in near real-time may differ from the Predetermined IROL (No Margin) due to expected differences between off-line study and real-time conditions.³⁹
- **Real-Time IROL (with Margin):** This point is also determined in near real-time and includes some operating limit margin to keep the system from being operated too close to the Real-Time IROL (No Margin). Operating limit margin is often used as a conservative approach to account for uncertainties in the tool (e.g., modeling assumptions, simulated stressing patterns). Entities may or may not identify this as an IROL based on their own operating practices, similar to the pre-determined IROL (with margin).
- **Actual IROL (Real-Time or After-the-Fact Analysis):** In general, the system is operated within the IROL provided to the system operator either determined prior to real-time or near real-time. However, each operating condition has an actual IROL that is a function of system conditions, topology, power transfers, etc. The *actual* IROL value can either be determined in real-time or determined after-the-fact. This point corresponds to an operating state where the reliability of the BPS would be put at risk according to the definition of IROL if the given contingency(ies) were to occur. It is recognized that the Actual IROL determined by after-the-fact analysis (or real-time analysis) may differ from the predetermined IROL:
 - After-the-fact analysis of the Actual IROL is performed using a state estimate solution and set of credible contingencies to determine the actual point of instability uncontrolled separation, or cascading.
 - The Actual IROL can be calculated using real-time tools as part of the real-time assessment where tools are implemented and available.
 - IROLs provided to the system operator should be equal to or more conservative than the Actual IROL for that condition. If after-the-fact analysis shows that the Predetermined IROL was less conservative than the Actual IROL for those conditions, the SOL Methodology should be reviewed to ensure these types of conditions do not occur in the future.
- **Operating Alarm:** Entities may choose to trigger an alarm for operating conditions that could occur prior to reaching the Predetermined IROL or Real-Time IROL (either with or without margin) conditions and often take all available actions other than pre-contingency load shedding to avoid an IROL exceedance. The operating alarms give operators situational awareness, flexibility, and time to execute operating plans, which helps mitigate an exceedance of the operating IROL provided to the system operator.

The development and application of an operating limit margin is performed when defining the SOL or IROL. If margin is applied to an SOL or IROL, that limit is then provided to the operator with its respective classification as an SOL or IROL. However, different entities may treat how they incorporate operating limit margins into their determination of SOLs and IROLs as well as how they develop their operating plans. For example, one RC may establish the IROL as the actual point of system instability without a margin; they may then establish a SOL that includes an operating limit

³⁹ In rare instances, real-time tools used to determine the Real-Time IROL (with or without margin) may become inoperable. In these cases, the operating limit would revert to the Pre-Determined IROL (with or without margin) determined one or more days in advance. During this time, if the Pre-Determined IROL is exceeded it should be reported accordingly.

margin in front of that IROL such that an operating plan and associated actions are taken to minimize or mitigate the potential of an IROL exceedance. Another entity may not use an operating limit margin applied to the IROL itself; however, they may take mitigations steps as part of their operating plan as the IROL is approached. Another utility may determine the point of system instability and apply an operating limit margin to that point and then call this IROL with operating limit margin for their system. All of these classifications of IROLs are acceptable so long as the Actual IROL is studied, identified, and addressed accordingly through operating procedures.

While operating limit margin is a reduction in the allowable operating level or transfer capability on the system, it should be applied with technical basis that justifies the need for the margin from a reliability standpoint. The number of variables and level of uncertainty the BPS deals with on a continuous basis necessitates some operating limit margin to ensure Reliable Operation. The established limits and associated operating limit margins applied to them ensure that the system is not operated in a state where equipment loss of life, personnel safety, and undue risk of system instability, uncontrolled separation, or cascading may occur.

Note that the addition (or removal) of operating limit margin does not affect the T_v for IROLs. The IROL T_v concept to return to within secure operating conditions in a timely manner is decoupled from the use of operating limit margin. The IROL T_v timer starts when the predetermined (or real-time) IROL has been exceeded, regardless of whether operating limit margin is applied to the IROL.

In practice, operating limit margins are applied based on the type of SOL (or IROL) being developed:

- **Thermal-Based SOLs (or IROLs):** Thermal-based SOLs (or IROLs) typically do not use an operating limit margin because the industry has generally moved towards time-based facility ratings that provide sufficient time for operators to take corrective action to mitigate overloads (i.e., 30-minute, four-hour, or eight-hour thermal ratings). The inverse time-current relationship cannot be ignored since the development of the ratings incorporates these time aspects into the operating limits (thermal constraints) on the system. Exceedance of these limits for longer than the prescribed time duration may result in loss of life of the equipment. The RC or TOP should have operating plans in place to take action according to the severity of the overload and the time component associated with the facility rating. System Elements are not expected to remain within the 24-hour Normal Ratings following a contingency event; however, the Emergency Ratings should provide sufficient time for operators to take action according to their operating plans. Some RCs may use very short time duration limits (e.g., five-minute ratings) with only enough time to disconnect load (“load dump rating”) to mitigate the overload.
- **Voltage Stability IROLs:** Voltage stability IROL limits can take different forms. As an example, the IROL may be based on a P-V curve as shown in [Figure 1.6](#). The point of system instability occurs for this interface at 6,787 MW. However, a 200 MW operating limit margin⁴⁰ is applied (by the RC in this example) on the interface so the IROL with operating limit margin is 6,587 MW.

⁴⁰ The operating limit margin captures any uncertainties associated with large interfaces such as variance between studied and actual system conditions, unexpected contingency events, and un-modeled controls.

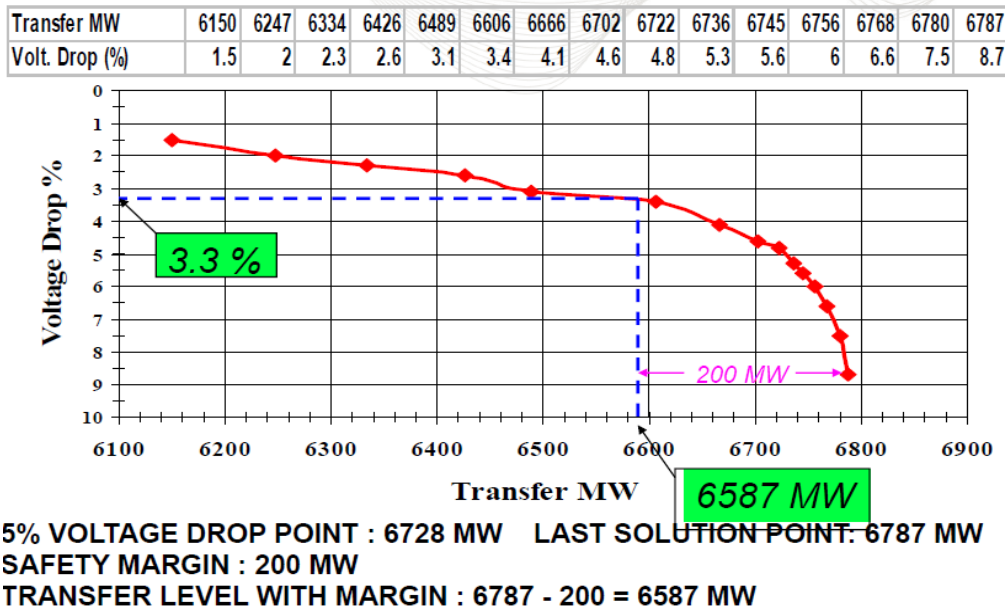

Figure 1.6: Example Margin Applied to P-V Curve

[Source: PJM]

- Transient Stability IROs:** Transient stability IROs often include some level of margin typically applied to an interface MW transfer or set of generator outputs, for example. Operating limit margins applied to transient stability IROs are used to account for a number of uncertainties or assumptions built into the studies, such as studied load level, transfers, generation dispatch, etc., particularly for off-line studies. Similarly, on-line study results may be computed with limited periodicity causing a similar issue. Operating limit margin should be applied to transient stability IROs (and SOLs) due to the complexity of transient stability simulations and the correlation to operating conditions (e.g., power transfers, unit dispatch, control set points).

Future work by the industry could explore methods for improved consistency of how operating limit margin is applied to different types of SOLs (e.g., voltage stability limits, angular stability limits). There is always some degree of error in the models used for establishing limits; therefore, operating limit margin is typically recommended for IROs unless sufficient operating plans or other SOLs are in place to manage the risk appropriately.

Study Assumptions and Study Criteria

In addition to applying an operating limit margin to an SOL, some form of “margin” may also be applied in other ways during the development of a SOL. Conservative study assumptions and study criteria can also be used to incorporate margins into the studies and therefore into the results to ensure reliability of the BPS. These are described below:

- Conservative Study Assumptions:** Every power system simulation is a numerical representation of a potential system state. The models, study assumptions, limits, and other factors in the study contain some form of conservative margin. For example, the studied system conditions may not match the actual system conditions that occur, and a more conservative operating point may be studied to ensure the bookend condition maintains stability (i.e., the less severe conditions should also maintain stability). Similarly, the selection of models or limits within the simulation can incorporate small margins built into the simulations. Likewise, the fault duration may be slightly extended (e.g., 3 cycle clearing studied as 4 cycle clearing) to ensure rotor angle stability for any breaker clearing time uncertainty. While these assumptions are a form of margin, they are not generally considered an operating limit margin from a practical standpoint; however, they may add some amount of safety margin to the study results. As near real-time conditions approach, the use of conservative assumptions should reduce—these study assumptions can be more accurately modeled to represent a more realistic representation of the expected operating state. For example, the conservative assumptions used in

deriving transient stability limits can be “layered” to add robustness to the calculated limit, including the following:

- Using post-fault transient voltage response criteria instead of the point of unit instability
 - Studying unit instability and oscillation damping at lower demand levels
 - Minimizing the number of partially loaded units (modeling units at or near max load)
 - Using a load characteristic with the least inherent damping (e.g., component of constant power loads, no motor load modeled)
 - Model units at as low a reasonable reactive output as possible (to reflect potential stability impacts of operation at leading or low lagging reactive power output)
 - Model the system voltage profile as high, and unit voltage schedule as low as is reasonable or possible to push on-line units toward leading operation
 - Model transfers on adjacent interfaces at potential maximums for transfer-based stability limits
 - Modeling automatic reclosing, where present, due to reclosing into a permanent fault potentially causing instability
- **Study Criteria:** The criteria for which simulation results are deemed acceptable or unacceptable can, and often do, apply a margin. This margin ensures that a stable post-contingency operating state can be achieved for the study assumptions made and simulations performed. For example, an oscillation damping criteria with margin applied may be used since unknown or un-modeled variables are not captured in the study simulations. Marginally damped conditions (i.e., near 0 percent damping ratio) may not be an acceptable post-contingency operating state since an equilibrium is not achieved. The time necessary to reach a new stable equilibrium operating state may be too long and unacceptable from a reliability standpoint.

Chapter 2: Classification of Power System Stability

IEEE and CIGRE define *power System Stability* for an interconnected bulk power system, such as those in North America as follows:

“Power System Stability is the ability of an electric power system, for a given initial operating condition, to regain a state of operating equilibrium after being subjected to a physical disturbance, with most system variables bounded so that practically the entire system remains intact.”

This is differentiated from other types of stability, such as stability of a particular generator or groups of generators (unit stability) and stability of a particular load or load areas (local load stability). For example, an individual unit may lose synchronism with the rest of the system without causing any instability of the interconnected system. Similarly, end-use motors may stall or trip on low voltage without causing instability of the interconnected system.

System stability and the analysis of stability can be characterized by three distinct steps [CIGRE/IEEE]:

- **Predisturbance Equilibrium:** System equilibrium implies that system variables (voltages, currents, phase angles, etc.) are balanced and the system operates around a point of convergence. Stability of the system is strongly affected by the system operating point prior to any disturbance occurring on the system. If the system is stressed beyond a certain level, it may not be able to withstand critical disturbance events and therefore be unable to regain a state of equilibrium following the contingency. System voltages, reactive power margins, transfer levels, transformer tap settings, system topology, and many other variables are indicators of the predisturbance equilibrium (operating point) of the system.
- **Disturbance (Contingency) Event:** Disturbances, in terms of stability analysis, are often characterized as either large disturbance (e.g., faults, generator trips, load rejections) or small disturbance (e.g., load variations). Different stability analyses address whether the system is able to withstand both the large and small disturbances such that the system is able to regain a new state of equilibrium following these disturbances. Large disturbances can be a discrete event, such as loss of large generators or loads. Other events may have a time duration associated with them (such as short circuit fault conditions) and the system must withstand the duration of these events as they occur (e.g., until protection systems are able to remove the event from the system). Small disturbances, while continuously occurring on the system, should not lead to instability of the interconnected system, such as undamped oscillations or voltage collapse.
- **Post-Disturbance Equilibrium:** After an event, system dynamics are studied, and the motion or response of the system is characterized by various criteria to determine the level of stability achieved by the system for the specified initial equilibrium point and the triggering disturbance. If the trajectory of the system remains within a viable operating range, allowing the system to regain a state of equilibrium, the system is considered stable. If the trajectory crosses the boundary of viable operating conditions and unable to regain a new equilibrium point, the system is considered unstable. Discrete, controlled actions may occur to ensure that the system stays within a viable operating region (e.g., Remedial Action Schemes (RAS); automatic controls at generators, loads, and transmission equipment; HVDC controls; fast-switched devices; and other actions). When the system exceeds the boundary of viable operating conditions, software tools may not be able to determine the extent of system conditions since they are unable to numerically determine an operating point. This situation is discussed in length throughout this document. In other cases, actions prior to reaching this unviable operating point can occur and can be studied to identify how the system will respond and if a new equilibrium point will be achieved. Planning and operating criteria should be in place to identify if actions taken to reach a new equilibrium point (e.g., excessive load loss, transmission switching, generator tripping) ensure a reasonable level of reliability.

Overall power system stability is generally discussed as one concept. However, due to the complexity and large number of variables in a typical power system, power system stability is often classified by categories or types of stability. **Figure 2.1** shows a categorization developed by IEEE/CIGRE and further elaborated upon by the NERC MEITF. Categories of stability are based on the physical phenomena that can result in system instability. These categories are further broken down into sub-categories often based on the time frame for which these instabilities could occur (e.g., short-term vs. long-term). Each distinct sub-category of stability is then categorized by the types of tools and techniques used to study that particular type of stability. Classification of the different types of stability and their assessment is discussed in more detail below.

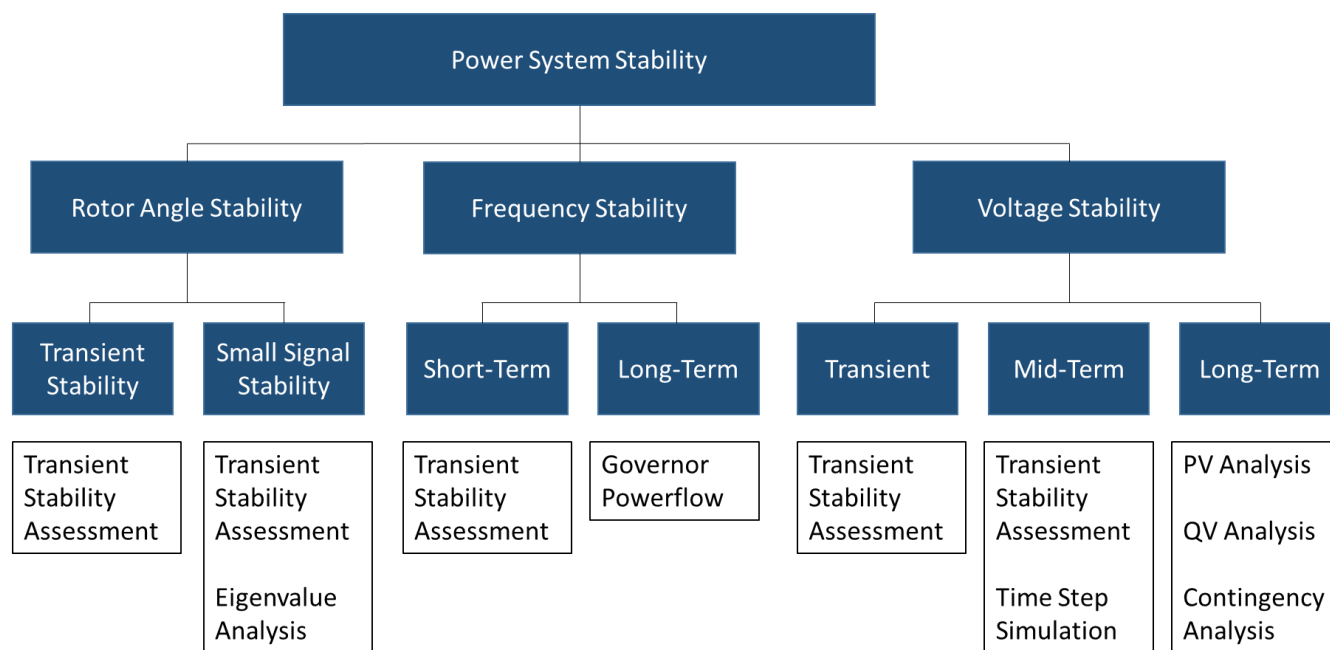

Figure 2.1: Classification of Power System Stability

[Source: Adapted from IEEE/CIGRE ©2003]

Rotor Angle Stability

IEEE/CIGRE defines rotor angle stability as follows:

“Rotor angle stability refers to the ability of synchronous machines of an interconnected power system to remain in synchronism after being subjected to a disturbance. It depends on the ability to maintain/restore equilibrium between electromagnetic torque and mechanical torque of each synchronous machine in the system. Instability that may result occurs in the form of increasing angular swings of some generators leading to their loss of synchronism with other generators.”

Rotor angle stability is an electromechanical phenomena involving the equilibrium between the mechanical input torque and electromagnetic output torque of each generator and how generators balance the torque-speed relationship across the system. Rotor angle instability occurs when the system cannot absorb a sufficient amount of kinetic energy as generator speed increases. Changes in the electromagnetic torque of a machine are often broken into two components:

- **Synchronizing Torque:** component of torque in phase with the rotor angle deviation; insufficient synchronizing torque results in aperiodic rotor angle deviation instability

- **Damping Torque:** component of torque in phase with the speed deviation; insufficient damping torque results in growing oscillatory behavior

Instability results in the loss of synchronism of a single machine with the rest of the system or between groups of machines within the system. Each type of rotor angle instability should be avoided to maintain continuity of BPS generation and to protect the electric machine; however, each has its own level of severity from a BPS reliability perspective.

Rotor angle instability is typically separated into two categories of analysis: transient stability and small signal stability as discussed in the following subsections.

Transient Stability

IEEE/CIGRE defines transient stability as follows:

“Transient stability is concerned with the ability of the power system to maintain synchronism when subjected to a severe disturbance, such as a short circuit on a transmission line. The resulting system response involves large excursions of generator rotor angles and is influenced by the nonlinear power-angle relationship.”

Transient stability is commonly referred to as “large disturbance” angular stability since it relates to the ability of synchronous generators to maintain synchronism during large rotor angle swings when the system is subjected to large disturbances. Instability typically manifests as *first swing instability* where a generator or group of generators disconnects due to lack of synchronizing torque. It can also manifest due to the combination of multiple system modes, such as interarea and local modes causing instability after the first swing.

Stability of a given dynamic system is predominantly driven by the severity of the disturbance, system characteristics, and the initial operating condition prior to the disturbance. More severe disturbances cause larger angular excursions, and the planning paradigm today is to ensure system reliability under reasonable, credible contingencies that may result in instability. The system is considered stable if it can regain a state of equilibrium following the disturbance and the dynamic response of the system while maintaining continuity of practically all generators on the system. **Table 2.1** shows relevant study characteristics for transient stability analysis.

Consideration	Description
Analysis Time Frame	Three to five seconds Up to 30–60 seconds when dominant low frequency, inter-area modes are a concern
Analysis Tools and Methods	Transient stability software—rotor angle monitoring, damping criteria
Instability Impacts	Localized or widespread angular instability—tripping of generation and transmission circuits, operation of RAS, etc.
Containment Considerations	Rotor angle instability results in simulation outcomes that are not representative of actual system behavior if unstable machines are not dealt with, and they should be accounted for during assessment

Small Signal Stability

IEEE/CIGRE defines small signal stability as follows:

“Small signal stability is concerned with the ability of the power system to maintain synchronism under small disturbances. The disturbances are considered to be sufficiently small that linearization of system equations is permissible for purposes of analysis.”

Small signal stability is commonly referred to as “small disturbance” stability since it relates to the ability of the system to remain synchronized during small disturbances that continuously occur during normal operation of the grid. Small signal instability can manifest as either an aperiodic growth in rotor angles due to lack of synchronizing torque or growing rotor angle oscillations due to insufficient damping torque. Insufficient damping torque is more commonly experienced in large, modern power systems. Similar to transient instability, small signal instability can occur at localized power plants or system-wide.

- Localized small signal instability is due to a local plant mode being unstable. This is typically caused by insufficient system strength in the local area generator and plant control systems tuning and the plant operating conditions.
- System small signal instability is due to coherent groups of generators or power plants oscillating against other group(s) of generators in another area. These types of oscillations are referred to as inter-area oscillations and are usually well damped. However, the initial operating condition (system stress) as well as more complex tuning of control systems across a wide range of generators can affect small signal stability.

Table 2.2 shows relevant study characteristics for small signal stability analysis.

Table 2.2: Small Signal Stability Analysis Characteristics	
Consideration	Description
Analysis Time Frame	Steady-state pre- and post-contingency operating conditions
Analysis Tools and Methods	Eigenvalue analysis; transient stability simulations (Prony analysis)
Instability Impacts	Local unit instability (local modes), wide area instability (inter-area modes), excessive power swings, large-scale outages
Containment Considerations	Local unit instability may be demonstrated to be contained; challenging to differentiate impact or containment of wide-area Instability impacting a large portion of the Interconnection

August 10, 1996, WSCC Disturbance

Small signal instability played a key role in the August 10, 1996, disturbance in the Western Interconnection (then Western Systems Coordinating Council (WSCC)). A number of transmission elements, including lines and shunt capacitors, were forced out of service due to fault events, causing significant reactive demand on generation in the area. When the Ross-Lexington 230 kV line tripped at 3:47 a.m. Pacific Daylight Time, local reactive generation support was also tripped and power transfers were shifted to adjacent paths. This shift in power further resulted in increased reactive demand on the McNary hydro generators, resulting in their tripping. At this point, power oscillations became negatively damped as the Pacific Northwest hydro began to oscillate against other generators on the system. These oscillations grew until 1,000 MW and 60 kV swings were experienced on the interties and distance protection and out-of-step protection caused unplanned system separations. **Figure 2.2** shows the growing power oscillations on the California-Oregon Intertie (COI) during the event as well as the simulated response of the same event, stressing the need for representative dynamic models to study these types of phenomena.

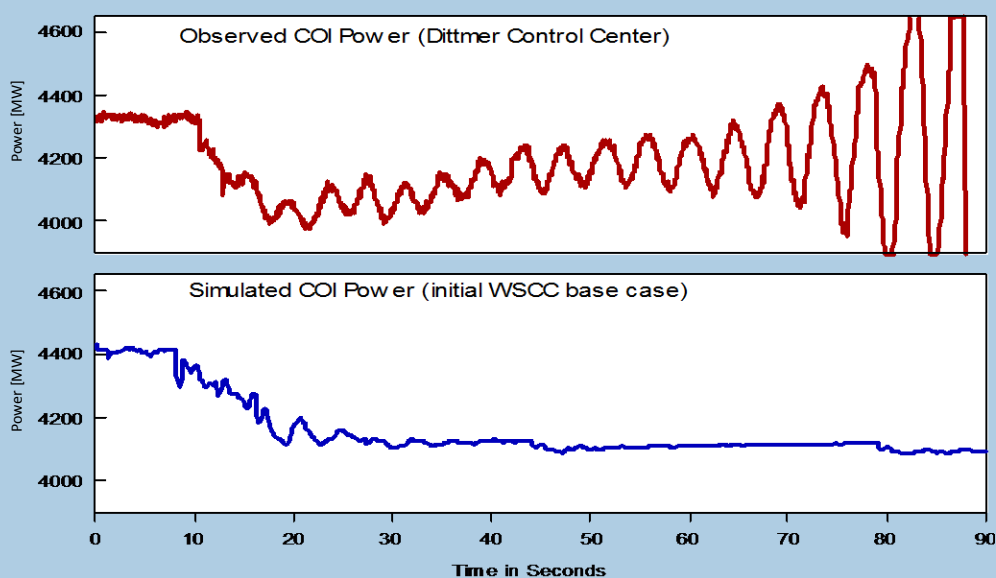

Figure 2.2: Power Oscillations for the August 10, 1996 WSCC Disturbance

Frequency Stability

IEEE/CIGRE defines frequency stability as follows:

“Frequency stability refers to the ability of a power system to maintain steady frequency following a severe system upset resulting in a significant imbalance between generation and load. It depends on the ability to maintain/restore equilibrium between system generation and load, with minimum unintentional loss of load. Instability that may result occurs in the form of sustained frequency swings leading to tripping of generating units and/or loads.”

Frequency stability is a more prominent reliability risk for smaller electrical interconnections or islanded systems. Larger interconnections, such as the Eastern and Western Interconnection do not exhibit significant frequency stability concerns unless island conditions under severe contingencies are being considered. Systems like the Texas and Quebec Interconnections may experience situations where frequency response and rate of change of frequency are more of a concern. Underfrequency load shedding (UFLS) is used as a protective measure, or safety net, to mitigate interconnection-wide frequency instability. Other low inertia systems, such as the Ireland and Hawaiian grids may deal with frequency stability limitations more directly due to their limited size and isolation from other large networks.

The amount of synchronous inertia and the rate of change of frequency are key factors for frequency stability. A higher synchronous inertia (e.g., Eastern Interconnection) will hinder or deter large, fast changes in frequency. This provides more time for primary frequency response, such as governor response, to respond to the changing grid frequency. Conversely, systems like the Texas and Quebec Interconnections with lower synchronous inertia may be faced with a faster rate of change of frequency under certain conditions of low synchronous inertia and may need to take preventative measures to ensure frequency stability.

Frequency stability can also be impacted by coordination, timing of controls, and sufficiency of reserves to deploy. A continuum of frequency responsive reserves and controls should be used to ensure stable recovery of frequency following large changes in the generation-load balance. Plant-level controls should not withdraw response when frequency is still low and should be biased to account for these conditions. Ensuring sufficient amounts of frequency response reserve at the Balancing Authority level ensures widespread support to grid frequency recovery under abnormal, degraded frequency conditions.

While longer-term frequency stability analysis is a classification of frequency stability, it is typically not studied for larger interconnected systems. This time frame includes complex interactions between turbine speed controls, boiler or reactor protection and controls, and other longer-term controls typically not modeled in dynamic simulation tools. Conversely, short-term frequency stability is a key factor, particularly in the situation of islanding. When planned or unplanned islands are formed on the grid, the balance of generation and load in those new islands will determine if the island can regain a stable operating point. If the amount of frequency responsive resources are insufficient to mitigate the imbalance, the island may risk frequency instability. Frequency stability is often involved, to some degree, in determining whether the system will retain stable islands or whether widespread outage will occur following other forms of instability, cascading, or uncontrolled separation. However, frequency stability is usually not a key contributor to the instigating event in larger interconnected power systems.

Lastly, frequency stability is affected by the relative size of the resource loss considered for a given Interconnection. For example, a 3,500 MW loss of generation will have a significantly different impact on a large interconnected system, such as the Eastern Interconnection, than it will on a smaller interconnected system, such as the Texas or Quebec Interconnections. The largest credible contingency, studied from a frequency response perspective, is different for each Interconnection but driven by reasonable or expected events that could occur, resulting in a large loss of generation. One mitigating measure that some Interconnections have used as a form of frequency stability protection under low-inertia conditions is limiting the dispatched generation for the largest credible resource loss to reduce its impact.

Table 2.3 shows relevant study characteristics for frequency stability analysis.

Table 2.3: Frequency Stability Analysis Characteristics	
Consideration	Description
Analysis Time Frame	Seconds to minutes
Analysis Tools and Methods	Transient stability simulation, governor powerflow simulation; monitoring bus frequencies
Instability Impacts	Activation of UFLS, system islanding, unexpected turbine-generator tripping, frequency-sensitive load tripping, large-scale outage
Containment Considerations	Generator ride-through; UFLS as proxy for frequency instability protection; no clear boundary of containment when frequency instability occurs;

Voltage Stability

Voltage stability can be defined as follows:⁴¹

“Voltage stability is the ability of a power system to maintain steady acceptable voltages at all buses in the system under normal operating conditions and after being subjected to a disturbance. A system enters a state of voltage instability when a disturbance, increase in load demand, or change in system condition causes a progressive and uncontrollable drop in voltage. The main factor causing instability is the inability of the power system to meet the demand for reactive power.”

Voltage stability is tightly linked with the other forms of stability. For example, interarea oscillations between groups of machines will cause voltage fluctuations at intermediate points across the system, largest somewhere near the electrical midpoint. As these oscillations grow towards 180 degrees, voltages will begin to rapidly decline due to the rotor angle instability and potentially cause a fast voltage collapse. Generally, the analysis and characterization of voltage instability excludes these interactions or conditions where the decrease in voltage is driven by angle instability.

The most common outcome or system response of voltage instability is the decline of bus voltages. As reactive power support diminishes or becomes inadequate, the electric fields cannot be sustained and voltage drops. Therefore, it is typical to discuss voltage stability considerations and reactive power support as a single concept. Changes in voltage and reactive support requirements are driven by specific system characteristics, dynamic and static reactive resources, control systems and limiters, and considerations for operator actions to support voltage. While low voltage is generally the focus for voltage collapse, overvoltage issues could result in instability and this has occurred on at least one system.⁴² Also considered is the concept of fault-induced delayed voltage recovery (FIDVR) where the stalling of single-phase air conditioners can result in sustained low voltages and potential overvoltage due to load tripping.

Voltage response and voltage stability can impact transmission and generation elements and cause inadvertent tripping of these system elements. Generator over-excitation (and under-excitation) limiters will eventually limit the amount of reactive current synchronous machines can provide. Sustained low voltage may cause generator auxiliary loads to trip and subsequently trip the generating resource. Similarly, severe low voltages may cause end-use load tripping and other non-linear control actions to occur.

The analysis of voltage stability is often classified according to the time frame in which the instability may occur, and this is generally broken down into steady-state (long-term), mid-term, and transient (short-term) voltage stability. These time frames are based on the devices, processes, and phenomena that dominate the system response. These are described in more detail in the following subsections.

Transient (Short-Term) Voltage Stability

Transient voltage stability refers to the ability of the BPS to support system voltages by maintaining adequate *dynamic* reactive power support following large disturbances. Typically, this time frame captures up to 30 seconds after the disturbance. During the transient time frame, voltage stability is predominantly determined by *dynamic* MVAR availability because the short-term reactive capability of synchronous generators is typically significantly higher than their continuous capability. The changing resource mix is causing a renewed focus on transient voltage stability since inverter-based resources do not inherently have this capability and are limited by the short-term capability of the inverters (typically 110–120 percent of nominal rating) and current is limited by controls and protection. In addition,

⁴¹ P. Kundur, *Power System Stability and Control*, McGraw-Hill, 1994.

⁴² T. Van Cutsem and R. Mailhot, “Validation of a Fast Voltage Stability Analysis Method on the Hydro-Quebec System”, *IEEE Trans. on Power Systems*, Vol. 12, No. 1, pp. 282-292, February 1997.

induction motors at the distribution level, especially single-phase residential air conditioners, may stall and consume large amounts of reactive power (up to around seven to eight times rated demand) and are subsequently tripped by thermal protection between three to 20 seconds after stalling.

In the short term time frame, the following controls and devices should be represented as appropriate:

- Generator automatic voltage regulators (AVR)
- AVR over-excitation and under-excitation limiters (where applicable, depending on design)
- Generator turbine-governor controls, HVDC controls, and other fast-acting FACTS controls effects
- Generator voltage protective relay settings
- Transmission protective relays that may respond to low voltages or high reactive power flows
- Remedial Action Schemes (RAS)
- Under-voltage Load Shedding (UVLS)
- Dynamic load characteristics including the effects of induction motor loads
- Fast switching automatic shunt devices

Short-term voltage instability can be adequately studied with dynamic stability tools with accurate load models and models of protection and control devices. Although the undervoltages and overvoltages are transient, it is important to study this time frame since in severe situations they result in generator trips, transmission relay trips, and under-voltage load shedding that would not be captured in steady-state studies. Additionally, the coordination of RAS's, UVLS schemes, and other protection and controls requires the insights that can be gained only from dynamic stability analysis.

July 29, 1995, Phoenix FIDVR Event

During peak summer conditions on July 29, 1995, the Phoenix area experienced a significant delayed voltage recovery event, referred to as FIDVR (see left side of [Figure 2.3](#)). A delayed clearing fault on a 230 kV capacitor bank resulted in five 230 kV lines to trip immediately and two more 230/69 kV transformers tripped three seconds later. Residential voltages fell to 58 V_{RMS}, and it took approximately 20 seconds for voltages to recover. However, nearby nuclear units were able to rapidly increase their reactive output to very high levels to prevent voltage collapse (see right side of [Figure 2.3](#)). A total of 2,100 MW customer load, primarily single-phase air conditioners, disconnected on thermal protection. As a result, one nuclear unit went from 600 MVAR lagging to 200 MVAR leading over a short time frame. This type of voltage stability is studied using dynamic stability analysis tools since steady-state tools do not capture dynamic load performance, capability of nearby generators to rapidly increase reactive output, or protection and control devices that may operate.

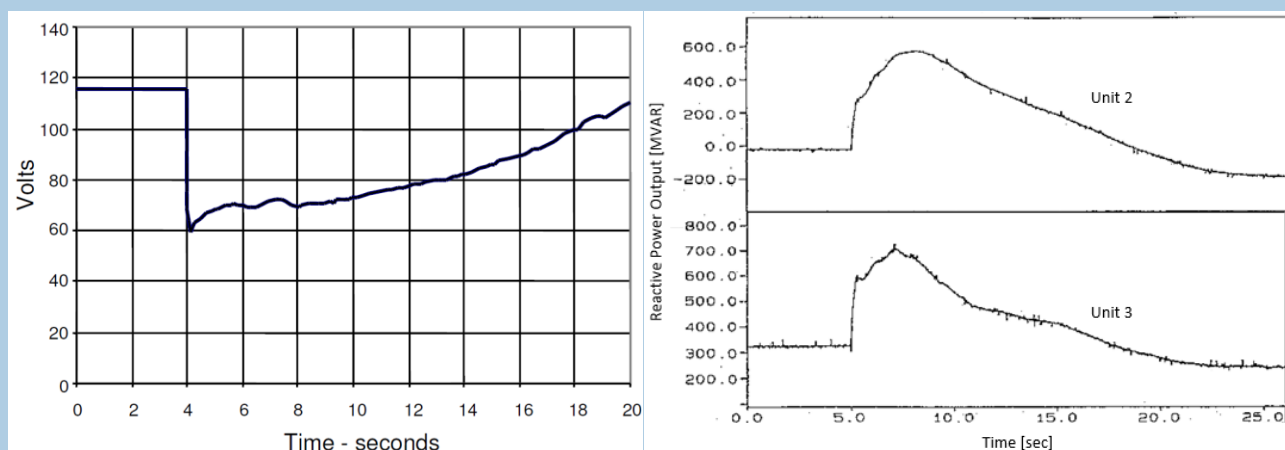

Figure 2.3: Short-Term Voltage Stability (FIDVR) Event in Phoenix Area

[Source: Voltage Stability for Undergraduates, Carson Taylor]

July 2, 1996, WSCC Disturbance

The July 2, 1996, WSCC disturbance was initiated by the loss of two 345 kV transmission circuits due to a single phase fault and relay misoperation. The loss of these lines correctly initiated a RAS that tripped 1,040 MW of generation; however, a poorly calibrated Zone 3 relay also tripped a 230 kV line. At 10 seconds after the initiating event, a 26 MW generator tripped on field excitation overcurrent relays. At 12 seconds later, another 26 MW generator tripped for the same reason followed quickly by a 230 kV line tripping by Zone 3 relays. Following the line trip, voltage began to collapse rapidly in Idaho and Oregon (see [Figure 2.4](#)). Several more units tripped on field excitation overcurrent relays within a few seconds and multiple 230 kV lines tripped on Zone 2 or Zone 3 relays. The Pacific DC Intertie (PDCI) initially tried to maintain transfer levels by increasing line current, alleviating the burden on the AC system. However, the maximum current limit was reached by the PDCI and line current was reduced further exacerbating the problem. Eventually, the WSCC separated into several islands through the action of distance relays, out-of-step relays, and RAS actions.

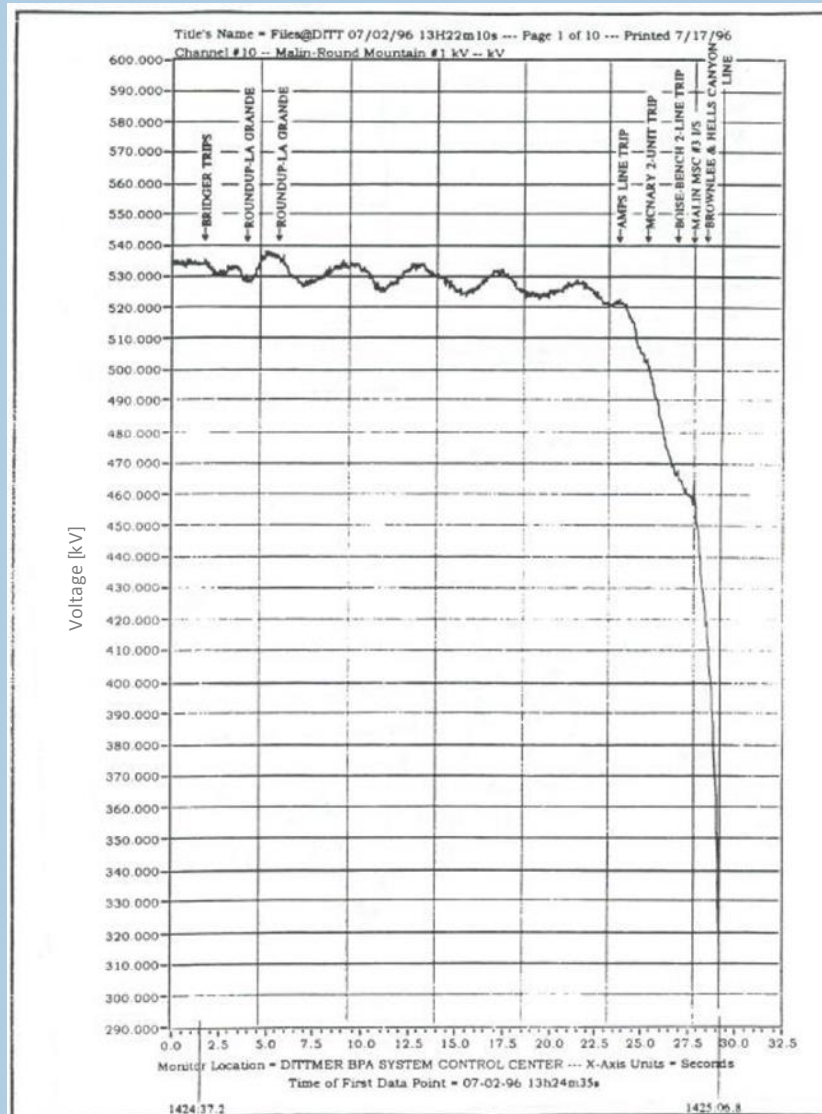

Figure 2.4: Voltage Collapse for the July 2, 1996, WSCC Disturbance

Mid-Term Voltage Stability

Mid-term voltage stability refers to the ability of the BPS to transition from the transient time frame (less than 30 seconds) to the multiple minute time frame during which system load and generator response should have stabilized. During this period, numerous factors are in play. Load tap changing (LTC) bulk transformers in automatic mode are actively returning their low side bus voltages to scheduled value after the tap changing mechanism begins acting, usually in the 30 to 60 second time frame. These devices typically have a tap step time delay of around five seconds between distinct tap steps. Distribution voltage regulation, commonly found at the distribution stations as either bus or feeder regulating transformers with automatic LTCs, will begin returning customer voltage to desired levels with similar actuation and time delay time frames. Shunt reactive devices, such as transmission or distribution capacitors or reactors, may be switched by using automatic controls to return voltage to within a voltage threshold; these controls may be fast-acting, and start within the transient time frame (five to 15 seconds), or may have longer time delays and start responding in the 30–60 second time frame or longer. Ideally, the TOPs and DPs have coordinated the response of these system elements at the transmission and distribution, respectively, to utilize the various reactive elements in a specific manner.

While voltage is being restored through the use of these devices, generators and dynamic reactive devices (e.g., SVCs and STATCOMs) are actively trying to control to scheduled set point voltage. Reactive current limiters on generators may act in this time frame, limiting generator reactive output to within the continuous range. Limiters may allow field voltage or field current to be 120–160 percent of continuous capability for a short duration in the transient time frame; however, this typically reduces in the long-term closer to continuous capability. **Figure 2.5** shows an illustration of an inverse-time characteristic over-excitation limiter where the allowable time duration depends on the magnitude of the high field voltage or field current.

Voltage instability arises in this time frame when system reactive demands cannot be met by dynamic and static reactive resources with the applied control schemes (e.g., automatic generator controls, dynamic reactive resource control, controlled shunt devices, and LTCs) and unacceptably low voltage or voltage collapse ensues. Generator terminal voltages should be monitored to identify plants that could exacerbate the problem due to unintended tripping by auxiliary systems. These help identify useful sensitivity studies to perform for deeper defense in depth.

Mid-term voltage stability is typically examined by using dynamic stability analysis tools. In addition to the models used for transient stability analysis, models for any automatic LTCs (bulk and distribution), generator over-excitation limiters, appropriate dynamic load models, automatic switching controls for any switched shunt elements, and protection schemes that may act in this time frame (e.g., line relays, local RAS, generator under-voltage protection (commonly on distribution-connected generation), and active UVLS schemes) should also be considered. While this time frame of analysis is not common due to the complex modeling requirements, it is an effective technique to determine if the system can successfully transition to the long-term voltage stability time frame where other techniques can be used to determine system performance.

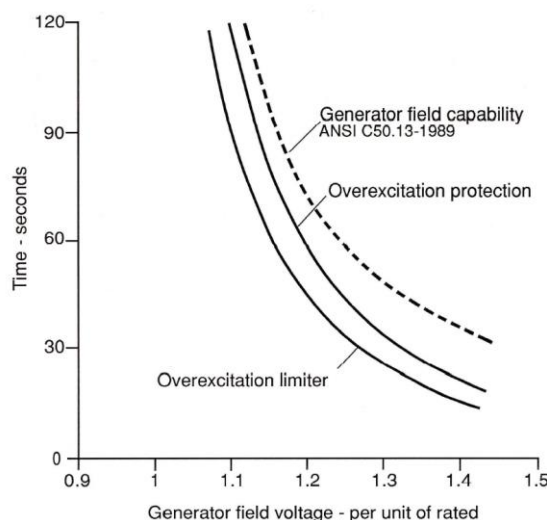

Figure 2.5: Inverse-Time Characteristic Over-Excitation Limiter

September 23, 2003, Sweden Denmark Disturbance

The southern Sweden and eastern Denmark systems experienced mid-term voltage instability on September 23, 2003. Five minutes prior to the voltage collapse, an 1,175 MW nuclear power plant tripped and expected frequency and voltage transients ensued. All system quantities stabilized within normal operating limits. At 12:35 local time, a double bus-bar fault caused two 900 MW nuclear units to trip. **Figure 2.6** shows that after severe voltage and frequency fluctuations, voltage appeared stabilized and above 95 percent of nominal (400kV). Frequency also stabilized above 99.4 percent of nominal (50 Hz). However, as automatic LTCs acted to increase distribution voltages, area loads steadily increased and transmission voltages slowly collapsed. About 97 seconds after the initial event, voltages collapsed, resulting in system separation and load shedding.

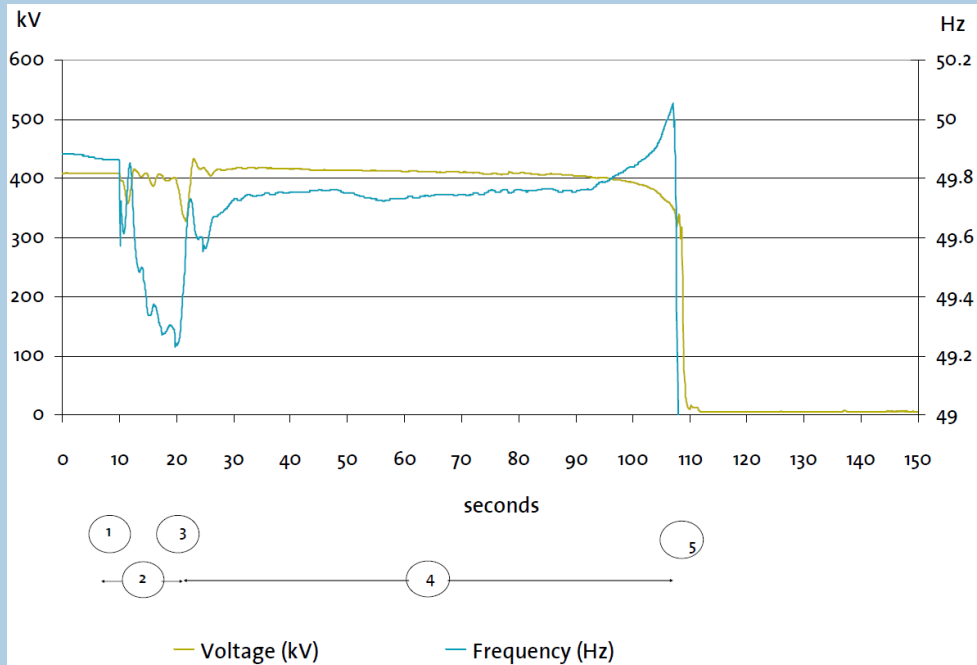

Figure 2.6: Voltage and Frequency at Odensala 400 kV Substation during Voltage Collapse

[Source: IEEE]

Steady-State (Long-Term) Voltage Stability

Long-term voltage stability refers to the system's ability to maintain steady voltages once a new operating state is reached, typically well beyond the transient and mid-term time frames. During the long-term time frame, voltage stability is predominantly driven by the system reaching a new steady-state operating point following LTC and voltage regulator action to return voltages to within acceptable limits. Reactive power support from either dynamic or static resources is the main focus. Overall load response to changes in voltage (i.e., decreasing demand due to low voltage) is an important consideration and may actually have a stabilizing effect on voltage stability. Operator action may or may not be considered in the long-term voltage stability analysis depending on utility practices and whether sufficient time is available for switching static reactive devices.

Since long-term voltage stability is a steady-state phenomena, stability analysis can be performed using one or a sequence of powerflow simulations. These simulations approximate limiters by enforcing generator reactive power limits and approximate distribution voltage regulator and tap changer action by assuming constant power loads. A major advantage of power flow studies for long-term voltage stability analysis is that there are well established techniques that provide a measure of the margin to instability, including techniques like P-V and V-Q analysis. These

studies are not intended to capture dynamic phenomena, such as induction motor stalling, large voltage fluctuations, or activation of protective relays.

In P-V analysis, system voltages are monitored as real power transfer across an interface (between a predefined source and sink) is increased until the power flow solution no longer converges. This analysis can be performed for pre-contingency conditions or post-contingency conditions by performing contingency analysis at each step. **Figure 2.7** illustrates a typical P-V curve for pre- and post-contingency conditions. The difference between the initial operating point and the point at which the power flow fails to solve for the studied contingencies (the nose of the P-V curve) is called the P-V stability margin. Since the system is required to be N-1 secure, the post-contingency P-V margin indicates the distance to instability. While the distance to instability can be determined efficiently, P-V analysis may provide limited information regarding how the voltage instability manifests or whether it is contained to a localized area unless further analysis is performed.

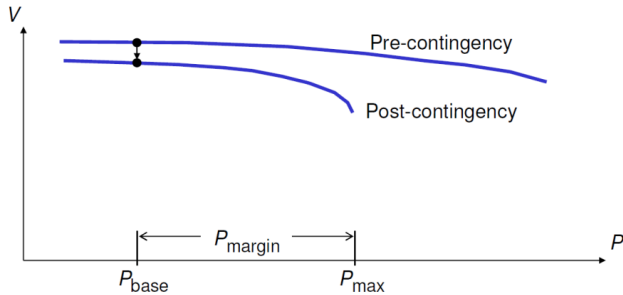

Figure 2.7: Example of PV Analysis Curves

VQ analysis is performed to understand how variations in reactive power injection at a single bus affects the voltage at that bus. A fictitious synchronous condenser is placed at the bus and the voltage set point is varied. MVAR output of the fictitious synchronous condenser is recorded at each step in voltage set point. Similar to P-V analysis, this can be performed both for pre- and post-contingency conditions. Even when considering post-contingency scenarios, the term “base case operating point” is often used to describe the point where the output of the fictitious synchronous condenser is 0 MVAR. The minimum MVAR point on the curve represents the maximum increase in load MVAR that can occur before voltage collapse occurs. The bus where reactive margin reaches 0 MVAR becomes the limiting element from a reactive support standpoint.

Figure 2.8 shows VQ plots for stable and unstable systems. The first figure shows that an additional 170 MVARs could be absorbed at the bus before voltage collapse occurs. However, the second figure represents an unstable situation where an additional 70 MVARs would be required for the power flow to solve. One benefit of VQ analysis is that it can provide the required MVAR support needed for a stable operating condition since the fictitious synchronous condenser can provide the necessary MVAR to reach a numerically stable operating point. However, a drawback is that this analysis must be performed comprehensively to determine the limiting bus or areas where reactive power is deficient. A VQ curve can be created at each point on a P-V curve. VQ analysis is particularly useful for determining the weakest buses in an area, the most effective locations to install reactive compensation, and how much reactive compensation is required.

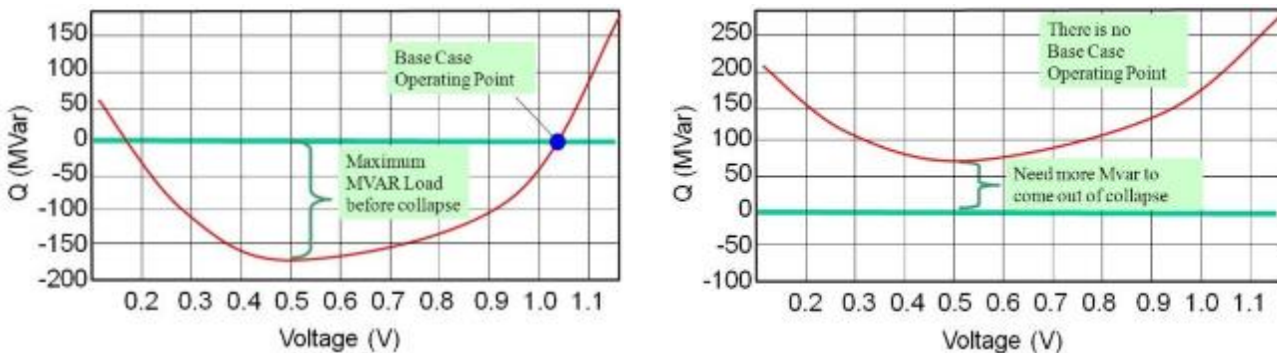

Figure 2.8: Example of Stable and Unstable VQ Analysis Curves

[Source: PowerWorld]

Table 2.4 shows relevant study characteristics for voltage stability analysis.

Table 2.4: Voltage Stability Analysis Characteristics	
Consideration	Description
Instability Impacts	Localized or widespread voltage collapse – potential tripping of generation and load on low voltage conditions, operation of protective relays, etc.
Long-Term Voltage Stability	
Analysis Time Frame	Steady-state (post-contingency) conditions
Analysis Tools and Methods	Powerflow contingency analysis, P-V analysis, V-Q analysis, continuation powerflow methods
Containment Considerations	Series of curves (quantity of curve); voltage contours on oneline to show boundary of instability; modeling or protective relay action, if available; no numerical solution at point of collapse (excluding continuation powerflow method)—back away to last solved powerflow solution.
Mid-Term Voltage Stability	
Analysis Time frame	5 seconds up to multiple minutes
Analysis Tools and Methods	Transient stability software; time step simulation—Monitoring wide-area voltages to identify collapsing voltages; determination of a clear boundary of collapsing bus voltages
Containment Considerations	Consider actions of AVR, OEL, LTCs, phase shifters, automatic switched shunts, other automatic devices, RAS, protection; protective relay action, if applicable; dynamic load modeling
Short-Term Voltage Stability	
Analysis Time Frame	Up to 3-5 seconds
Analysis Tools and Methods	Transient stability analysis—voltage deviation monitoring, transient voltage response monitoring
Containment Considerations	Voltage stability results in simulation results that are not representative of actual values (numerical instability); must be accounted for during assessment

High Frequency and Control-Related Stability

The interaction of the electrical and mechanical components of the power system and the interaction between control systems is briefly introduced in this section. These topics are highly complex issues that require detailed studies. The consequences of these types of stabilities could result in damage of equipment or safety concerns and therefore are taken very seriously regardless of their classification as a SOL or IROL.

Subsynchronous Resonance (SSR) and Subsynchronous Control Interaction (SSCI)

Subsynchronous resonance (SSR) is defined⁴³ as coincident oscillations occurring between generating resources and a series capacitor compensated transmission system at a natural harmonic frequency lower than the normal operating frequency of the electric system (60 Hz). This includes the following types of interactions:

- **Torsional Interaction (TI):** TI is the interplay between mechanical system of a turbine generator and a series compensated transmission system. TI involves both the electrical and mechanical system dynamics. When the torsional modal frequency of a turbine generator is close to the complement of the electrical system natural frequency, shaft torques due to torsional interaction could be expected to build up at a relatively slow rate to the damaging torque levels if the negative electrical damping exceeds the inherent positive mechanical damping.
- **Induction Generator Effect (IGE):** IGE is an electrical phenomenon in which resonance involving a generation resource and a series compensated transmission system results in electrical self-excitation of the Generation Resource at a subsynchronous frequency. IGE involves only electric system dynamics. When subsynchronous currents flow in the generator armature circuit, the generator appears as a negative-resistance circuit at the prevailing subsynchronous frequency. When this negative resistance exceeds the sum of the armature and network resistance at the resonant frequency, growing subsynchronous voltages and currents could be expected in the system and at the generator.
- **Torque Amplification (TA):** TA is an interaction between Generation Resources and a series compensated transmission system in which the response results in higher transient torque during or after disturbances than would otherwise occur. TA involves a significant fault and very high energy exchange between the series capacitor banks and the turbine generator. Fast growing and high shaft torques could be expected in a typical TA event.
- **Subsynchronous Control Interaction (SSCI):** SSCI is the interaction between a series capacitor compensated transmission system and the control system of Generation Resources. Similar to IGE, SSCI is also a purely electric phenomenon.

Frequency scan and EMT level simulation are two of the most popular and effective methods for SSR studies. As a screening method, frequency scan calculates the frequency dependent impedance as viewed from the neutral bus of the generator under study and then preliminarily determines the SSR vulnerability. The EMT level simulation applies the detailed EMT model in time domain to determine the SSR vulnerability in more accurate way.

Control Instability and Control Interaction

The possibility of interaction between devices is very broad. Inverter-based resources may interact with each other or they may interact with other power electronic devices (such as HVDC ties), FACTS devices (such as SVCs or STATCOMs), or even with other devices that are not power electronic (such as series capacitors, switched shunts, and synchronous generators). Control instability can occur due to fast, high-gain inverter-based resource controller interactions with other nearby devices, such as HVDC converters, SVCs, STATCOMS, or other nearby inverter-based resources.

The weaker the system is in relation to the controlled devices the more impact each of the devices has on the others. In general, the open loop gain, as experienced by the interacting controllers, is higher when they are connected and operated in weak AC systems, making them more susceptible to control instability. This can result in undamped oscillations and/or tripping of generation resources and other equipment connected to the power system. Proper evaluation of control instability in weak networks requires a suitable simulation platform, such as an electromagnetic transient simulation tool, that represents power electronic controls in sufficient detail to reflect their behavior under weak conditions.

⁴³ This definition is adapted from the ERCOT definition of SSR.

Table 2.5 shows relevant study characteristics for high frequency and control-related stability analysis.

Table 2.5: Control Instability/Weak Grid Analysis Characteristics	
Consideration	Description
Analysis Time Frame	One to 10 seconds
Analysis Tools and Methods	EMT simulation software—Transient stability analysis, monitoring voltage and electrical power (real and reactive)
Instability Impacts	Localized or widespread instability—tripping of generation and transmission circuits, operation of RAS, etc.
Containment Considerations	Local instability may be demonstrated to be contained; wide-area instability may impact a significant portion of interconnection

Chapter 3: Recommended Practices to Assess Instability

The types of stability described in Chapter 2 are interrelated both in terms of phenomena and with respect to determining SOLs and IROLs. When determining whether a potential instability condition warrants the establishment of an IROL, each stability assessment should consider the specific circumstances and characteristics of the system being studied as well as the tools and techniques being used to study the type of instability. This chapter describes recommended practices for assessing the impact that an instability can have on the BPS as well as the extent to which each type of stability assessment can make this determination. Key assumptions and recommended modeling practices for studies to establish IROLs are also described. In particular, each section may address the following:

- Tools and recommended techniques for studying each type of instability
- Key assumptions and limitations in assessing the impact of instability phenomena
- Time frames for which these phenomena will occur and the potential reliability risks associated with those time frames
- Quantification of the consequences of each type of instability
- Examples taken from existing systems and application of the assessment techniques

The impact that any type of instability can have on BPS reliability should be thoroughly studied and proven by study results. Instability events that can be proven to have a relatively insignificant impact on BPS reliability with minimal effect to the interconnection's reliability may not necessitate the establishment of IROLs. On the other hand, instability that cannot be proven to have a contained impact where simulation results are inconclusive and not supported by factual evidence should be mitigated using IROLs. A potential instability event that is not clearly studied and well understood should warrant the establishment of an IROL.

All types of stability assessment may consider the following aspects as part of the quantification of impact and determination of whether an IROL should be established:

- **Affected Amount of Load:** The total load affected by an instability should be quantifiable by the study results. Simulations that are not clearly quantifiable in terms of load impact should be treated as System instability.
- **Criticality of Load Lost:** Some loads are very critical in nature (e.g., national security, nuclear generating facility power supplies), and the RC may have a lower degree of risk tolerance for those types of loads. In those cases, an IROL may be established even if the instability is deemed acceptable due to the criticality of the load that is lost.⁴⁴
- **Number of Affected Elements:** The number of affected elements should be quantifiable. More localized issues will have a relatively small number of affected elements while widespread instability will have a much larger amount of affected elements.
- **Electrical and Geographical Area Affected:** An electrical boundary should be clear and quantifiable for a localized instability to be considered as "contained." It should be proven by study that the affected buses are localized to a relatively small and known area. This can be demonstrated using various techniques depending on the type of instability. Instability events where no clear boundary can be identified or the electric or geographic area is too large should be considered system instability, and an IROL should be established.
- **Instability Characteristics:** The instability characteristics (e.g., shape of the P-V curve, transient instability impacts) may be an indicator of how severe or impactful the instability may be. Engineering judgment should be used to ensure that the results are reasonable and representative of the impact to the BPS.

⁴⁴ The RC may use an IROL in certain situations to improve resilience. This may be particularly true in situations to bridge transmission investments to support identified load pockets or critical loads.

- **Operating Limit Margin Required for Acceptable Dynamic Response:** The amount of margin (e.g., power transfer) required to achieve an acceptably stable and reliable dynamic response following a near-Instability condition may also be considered. For example, if a transient system instability condition requires a 100 MW operating limit margin to achieve marginal stability, yet 150 MW operating limit margin achieves a much more reasonable and acceptable post-contingency conditions, the RC may adapt the IROL based on this. Similarly, if the operating limit margin to achieve acceptable postcontingency operating conditions is significantly large, this may further drive the need for an IROL to be established as well as an SOL with an operating plan to mitigate a potential SOL exceedance. Establishing operating limit margin is highly dependent on system characteristics and RC operating procedures.

Instability Impact Thresholds

While certain instability events may be thoroughly studied and determined to not have a wide-area impact to the BPS, like affecting neighboring RCs or causing instability in other parts of the system, each RC may develop a methodology for determining specific thresholds of reasonable size relative to the impact of an instability on their own system. Sustaining Reliable Operation of the BES, including generation and load, is paramount to maintaining adequate levels of reliability. Therefore, a significant loss of generation, load, or other system elements should not be acceptable and any contingency that would cause such a condition to occur should be mitigated with an IROL. Thresholds that the RC may consider include the following:

- The amount (MW) of generation lost due to an instability conditions
- The amount (MW) of load lost due to an instability condition
- The amount (MW) of generation lost that could result in further instability⁴⁵
- The number of tripped transmission elements
- Resulting system conditions from the loss of generation, load, or transmission elements

The technical basis for the methodology may consider a number of important factors, such as the following:

- The number of affected buses
- Electrical and geographical area of affected buses
- Margin to more widespread instability issues
- Risk of addition generation tripping and further instability
- Criticality of the load being served
- System restoration time and blackstart considerations
- Impacts to neighboring TOPs or RCs

Rotor Angle Instability Assessment Techniques

To describe the recommended analysis techniques for rotor angle instability, consider [Figure 3.1](#). A set of credible contingencies are studied as defined in the SOL Methodology. From those simulations, an instability condition has been identified that needs to be considered in more depth to determine whether the instability should be mitigated with an SOL or IROL.

⁴⁵ Note that this is causal to further instability as opposed to the first bullet which is an effect of the instability. Both of these situations are viable options that may be protected against using IROLs.

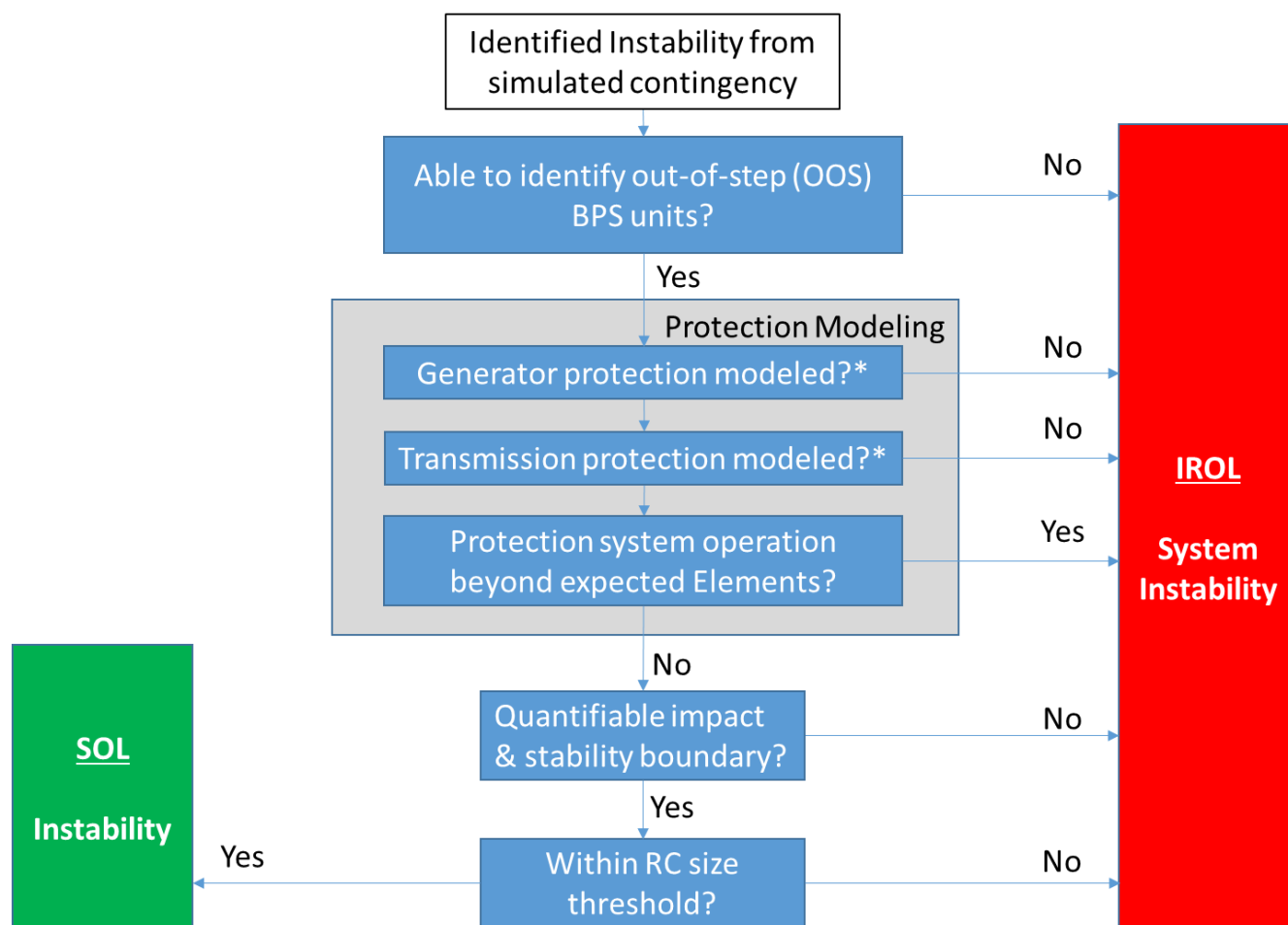

* Includes actual protection or generic protection to capture the general behavior of any protection system operation.

Figure 3.1: Rotor Angle Instability Analysis Flowchart

Identifying Units Losing Synchronism

Transient instability of a synchronous machine in simulation will result in increasing angles as shown in [Figure 3.2](#). One or more generators may pull out of synchronism—discernible by observing rotor angles in the simulation channel files. The example simulation clearly shows that the unit loses synchronism while the remaining machines maintain stability (as plotted showing worst rotor angle deviations of affected machines).

However, the simulation results may provide little value after the point of instability as demonstrated in [Figure 3.3](#) showing simulated bus voltages. Bus voltages near the instability show unreasonable data that should not be used to draw conclusions from after the instability point in this example. Similarly, frequencies across the Interconnection will also show unreasonable data that makes them unusable. To address this issue, the unstable machines should be removed from service in the simulation either through models (preferred) or engineering judgment (reasonable assumptions).

All unstable generators should be identified for any studied contingency. Contingencies within a study area should not cause instability of generating resources in a neighboring system, and those resources should be tracked accordingly. Similarly, any unit in the study area should be easily identified as unstable for the studied contingency. Situations where an instability is occurring and the simulation results may look abnormal or unusual, yet the instability cannot be identified, should be treated as a system instability since they are not thoroughly studied. This analysis should be based on validated modeling and appropriate inputs.

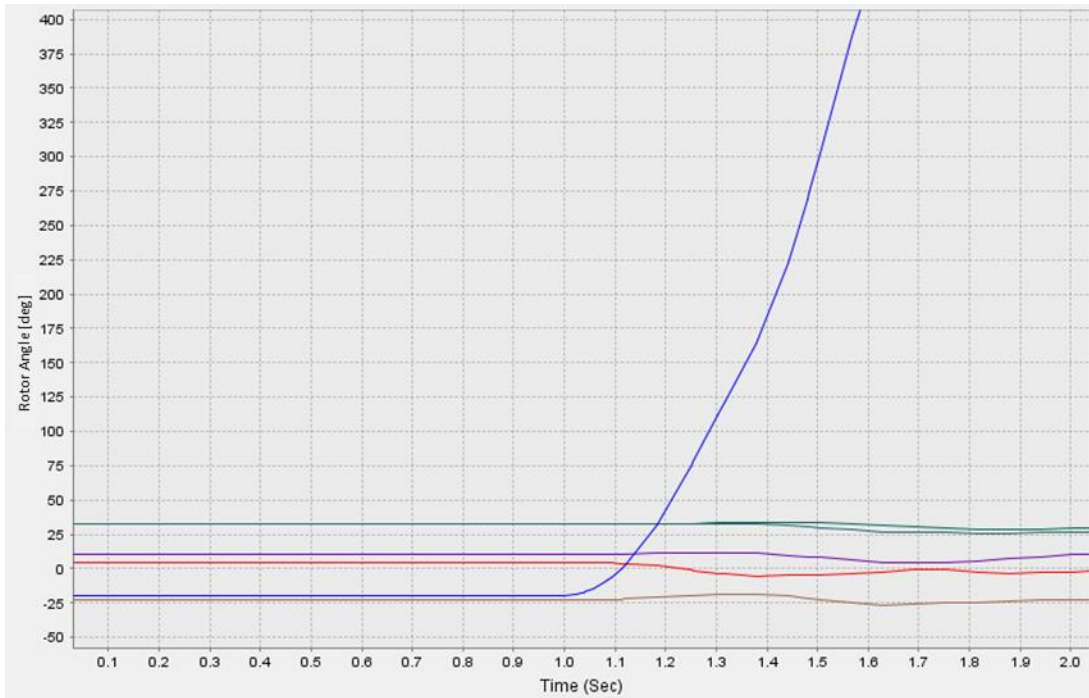

Figure 3.2: Example of Transient Instability Observed by Machine Rotor Angles

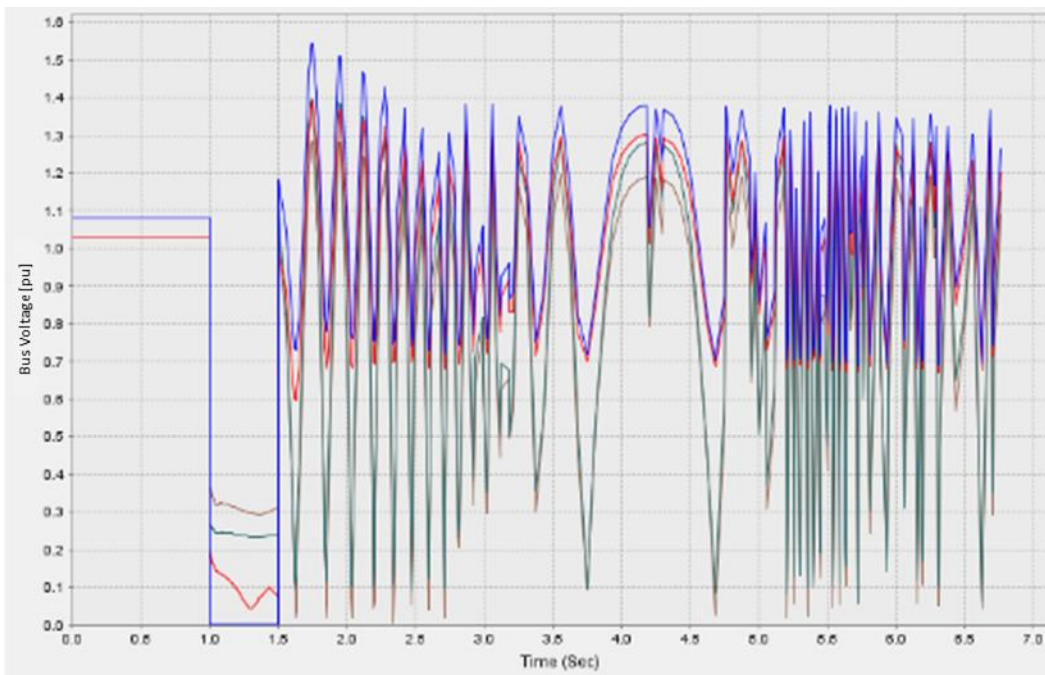

Figure 3.3: Bus Voltages for Transient Instability Example

Unit Instability vs. System Instability in TPL-001-4

NERC Reliability Standard TPL-001-4 Requirements R4.1.1 and 4.1.2 describe the extent to which unit instability is acceptable. These requirements state the following:

4.1.1. For planning event P1: No generating unit shall pull out of synchronism. A generator being disconnected from the System by fault clearing action or by a Special Protection System is not considered pulling out of synchronism.

4.1.2. For planning events P2 through P7: When a generator pulls out of synchronism in the simulations, the resulting apparent impedance swings shall not result in the tripping of any Transmission system elements other than the generating unit and its directly connected Facilities.

For P2-P7 contingency events, a generating unit is allowed to lose synchronism in the simulation so long as the resulting apparent impedance swings do not cause tripping of any system elements other than the unit and its directly connected facilities. This clearly describes that individual generating unit instability is acceptable for these contingencies; however, it should be demonstrated that there is no impact on the transmission system elements. This concept is considered in developing the techniques in this section.

Generator Protection Modeling

When a generating unit loses synchronism in a transient stability simulation, but is kept in service, the simulation results may not be sufficiently credible to draw useful conclusions. To address any numerical issues resulting from the instability, the unstable generating unit(s) can be monitored and tripped. Generally, there are four options for modeling generator out of step protection:

- **Actual Out of Step (OOS) Protection:** Actual generator out of step protection is rarely modeled, and the information is generally not easily attainable by the TP. In addition, modeling actual generator out of step protection is relatively difficult given today's dynamic model capabilities. For these reasons, modeling actual out of step protection is not typically performed by the TP/PC.
- **Generic Out of Step Protection:** If the unit has out of step protection, but detailed OOS settings are not available to the TP/PC, one may assume generic or expected settings for the OOS protection by employing system-wide monitoring models. Some system-wide monitoring models include the capability to monitor and report circuits whose apparent impedance is less than the circuit impedance. Some of these monitoring models can monitor and report when the apparent impedance enters into the generic zones of protection of transmission lines or transformers. Monitoring models sometimes include the option to both report and initiate circuit tripping. When using "reporting only" models that do not have the capability to trip transmission circuits in simulations, often observation of the log file would result in confirmation that the impedance swing is well contained to the unit's generator step-up (GSU) transformer and thus there would not be a need for further investigation of that scenario. This is a reasonable approximation of the implementation of OOS protection consisting of an impedance relay located at the high voltage terminals of a GSU that is looking "back into" the GSU and unit. However, if the log files indicate that the impedance swing is outside the unit's GSU, and thus the OOS protection would not detect the impedance swing, additional consideration should be given as detailed in the upcoming section on "Transmission Protection Modeling." However, similar to modeling actual protection settings, these approaches are not usually employed.

- **Simplified Generator Tripping:** The stability simulation tools typically have generic scan tools that monitor each individual generator angle and compare it against the average system angle. A common assumption is that the unit will trip on out of step protection (or other relevant protection) once its rotor angle has exceeded 120 degrees relative to the other machines in the system. An angle threshold up to 180 degrees is sometimes used to ensure that the unit(s) is losing synchronism. Some simulation tools allow for a default OOS monitor to either alarm or trip on detected OOS conditions.

Out of Step Scan

Some software platforms have the capability to scan for potential out of step conditions using machine angles as a proxy. Machine angles are monitored and compared against a threshold relative to the system average angle. There is typically an option to either alarm or trip the unit(s), allowing the user to observe how the system will respond to the tripping of the generator following a loss of synchronism.

- **No Out of Step Protection:** If the unit does not have out of step protection, this type of protection should not be modeled. However, if the unit has out of step protection and no form of protection is modeled (including the simplified tripping), then one cannot discern useful information from the simulation and this should not be considered acceptable unit instability if it cannot be verified that the instability will not have an adverse effect on transmission or other system elements.

Once the actual, generic, or simplified forms of OOS protection have been modeled, this should alleviate the instability conditions causing numerical stability problems within the simulation. The results then provide reasonable channels for analysis. **Figure 3.2** shows the unit instability being detected via accelerating machine angles and manually tripping the generator in simulation. The resulting simulation shows reasonable voltages (see **Figure 3.4**), power flows, rotor angles, etc.

In addition to OOS protection, some dynamic simulation software packages include standard library models that include a suite of generic generator protection relays. Models can be applied to either individual generators or all generators in the system being studied. The model that can be applied to individual generators will trip the unit upon relay activation. System-wide models can be specified to trip or alarm upon relay activation. The available suite of generator relays includes undervoltage, overvoltage, field overcurrent, overfrequency, underfrequency, stator overcurrent, and reverse power. The type of functionality for the generic relays is, for the most part, definite time. Exceptions include the field overcurrent relay (inverse time) and the stator overcurrent relay inverse time characteristic with a voltage restraint. While default data associated with relay functions is provided, these values are configurable which does provide the user an opportunity to configure the relay functions to be similar to actual relay settings. Actual generator relay packages will vary in the implementation of their protective relay functions; however, having a model with a generic suite of generator protective relays with configurable settings does provide insight in assessing when generation protection could, or perhaps would, be expected to activate and trip the unit.

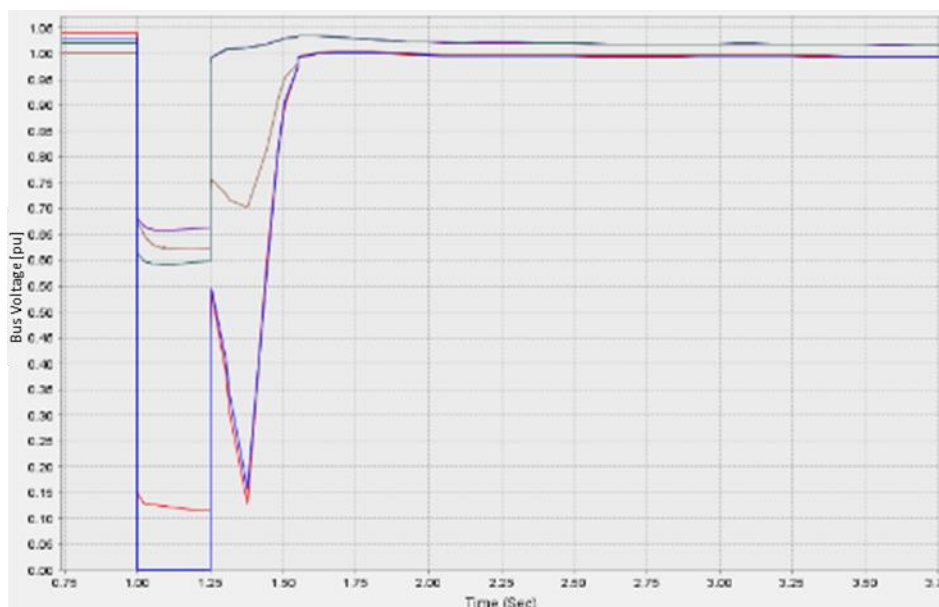

Figure 3.4: Acceptable Bus Voltages following OOS Trip

Transmission Protection Modeling

The other aspect that should be considered is the effect that the instability could have on transmission elements. In situations where instability occurs, there is a significant risk of undesirable tripping of transmission elements or other system elements. Therefore, some modeling of transmission protection and out of step protection needs to be considered to demonstrate that the resulting instability does not have an adverse impact causing additional tripping. The transmission protection should be modeled on these elements. Again, the modeled protection may be either:

- **Detailed Transmission Protection:** If available, detailed transmission protection settings can be used in the simulation to identify whether unit instability would result in additional tripping of transmission elements. This is the preferred practice.
- **Generic Transmission Protection:** In some situations where protection data may not be readily available, expected (generic) protection settings can be used to monitor whether the impedance swings could result in additional tripping. Specifically, system-wide monitoring models, which were discussed in the “Generator Protection Modeling” section, can be used to provide insight into which transmission elements might be tripped as a result of the impedance swing. If system-wide monitoring models are used that both report and initiate tripping of the circuits, then a reasonable expectation of the system’s performance following any transmission protection activation can be obtained. However, the use of detailed transmission protection models is preferred since unit instability has already occurred and an accurate understanding of its impact needs to be determined. If system-wide monitoring models are used, care should be taken to assess if transmission buses in the powerflow model are representative of actual boundaries of zones of protection. In cases where they are not, a more detailed generic representation of the transmission protection could be required in order to support a more accurate assessment of the impact of the instability.

It is reasonable to assume that the instability would have the most severe effect (and highest probability of tripping) on the transmission circuits adjacent to the unstable unit(s). For example, a generator connected to the BPS through three transmission circuits that loses stability for a fault and one of the transmission circuits should include an analysis on the impedance swings on the remaining two transmission circuits. Studying the protection will depend heavily on protection philosophies for the local TO. A distance relay including these protections can be modeled in the simulation (see [Figure 3.5](#) for a typical mho distance relay with three available zones of protection) using either actual parameters or generic parameters. [Figure 3.6](#) shows an example of the apparent impedance seen by the relay during

the fault (red dotted line) from an example simulation that shows that the unit would be tripped by its OOS relay before the impedance swing entered into any transmission line relay protection characteristics.

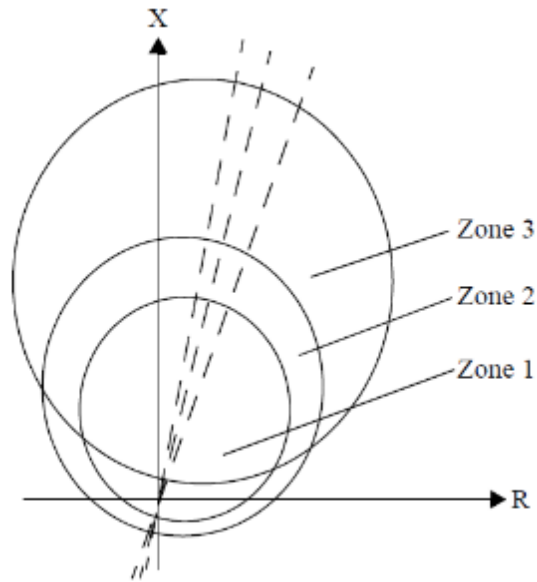

Figure 3.5: Generic Mho Distance Relay
[Source: PTI]

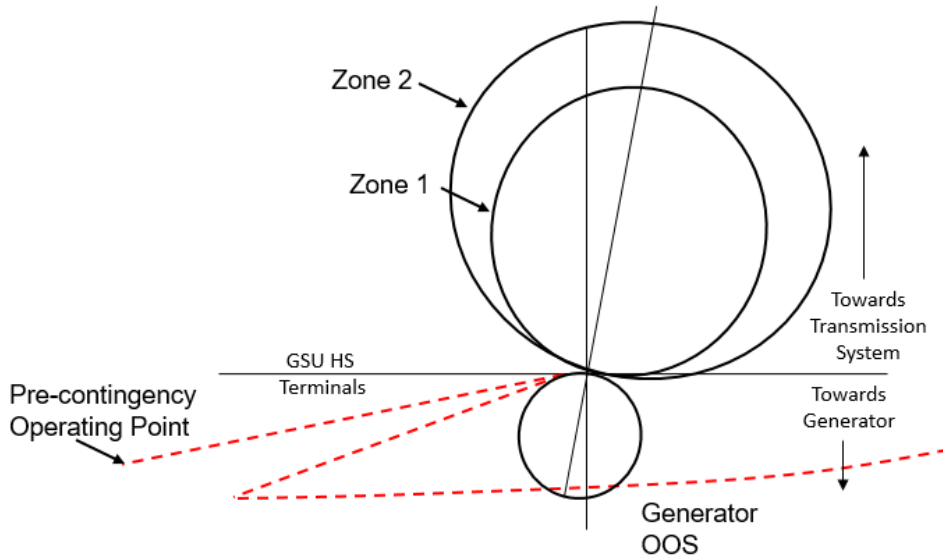

Figure 3.6: Impedance Swing Showing Generator Relay Activation, No Transmission Relay Activation

[Source: Southern Company]

This concept may apply to more than one generating unit; multiple units may lose synchronism without impacting any portion of the remaining system. For example, two generating units at a single power plant may lose synchronism based on their similar electrical connection to the BPS. However, even the loss of both elements does not result in tripping of any additional elements. Assuming the process above is followed closely and that it is clear via simulation that the potential instability and resulting tripping on OOS protection (or applicable protection) would not have an adverse impact, then this could be considered unit instability and not system instability.

Quantifying the Impact and Size of Transient Instability

It is important to include thresholds on the maximum amount of tolerable resource loss when considering instability events. While transient instability conditions may arise on a relatively localized basis, the size of these instabilities may not warrant safe and reliable operating practices due to the net loss of generation (or load) caused by the event. Exceeding such thresholds may cause unacceptable system dynamic behavior, instability, or voltage and frequency deviations that are outside acceptable criteria, or loss of parts of the system with unacceptable restoration time.

Figure 3.7 shows a system with a major power plant (3,000 MW) remotely connected to the main system and several generation/load centers through a network of EHV transmission circuits. With a planned outage, the most limiting contingency is a normally cleared, three-phase fault on a transmission line. A stability limit (rotor angle) exists along this corridor, and there is a need to determine if the transient instability should be classified as system instability and whether an IROL or SOL needs to be established.

Figure 3.8 shows the simulated bus voltage magnitude and frequency, respectively, for a bus remote from the contingency. No generator or transmission system protection is modeled in these simulations. The stable plots (blue) are obtained for a precontingency power transfer below the established SOL while the unstable plots (red) represent a precontingency power transfer above the established SOL. Key observations include the following:

- The oscillation that propagates through the system is typical for simulated unstable conditions where one or more generators loses synchronism with the rest of the grid. This type of simulation result is not acceptable when demonstrating containment or impact since the erratic oscillation behavior is a numerical issue caused by the unstable generator(s) remaining connected during the simulation.
- Analyzing the generator terminal and EHV bus voltage magnitudes prior to the point of instability may provide useful information as to the severity or likelihood of the instability. In this case, the voltage magnitudes fall very low prior to instability. Subsequent studies should model the protection⁴⁶ to ensure safe and reliable tripping and to identify whether the tripping may prevent continued instability (e.g., other units and/or system instability) from occurring.
- The frequency plot, although very noisy due to the instability, shows a probable path for system frequency after the generator tripping that falls below the minimum acceptable value of the first stage of UFLS for this system (58.5 Hz). This should be reverified once generator protections have been modeled and the generators are tripped in the simulation.

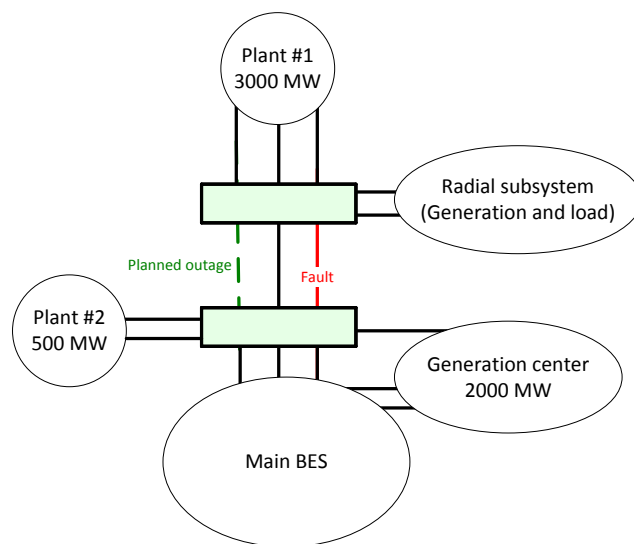

Figure 3.7: Example of Major Power Plant Connection SOL/IROL

⁴⁶ Actual or generic protection may be modeled to represent this behavior.

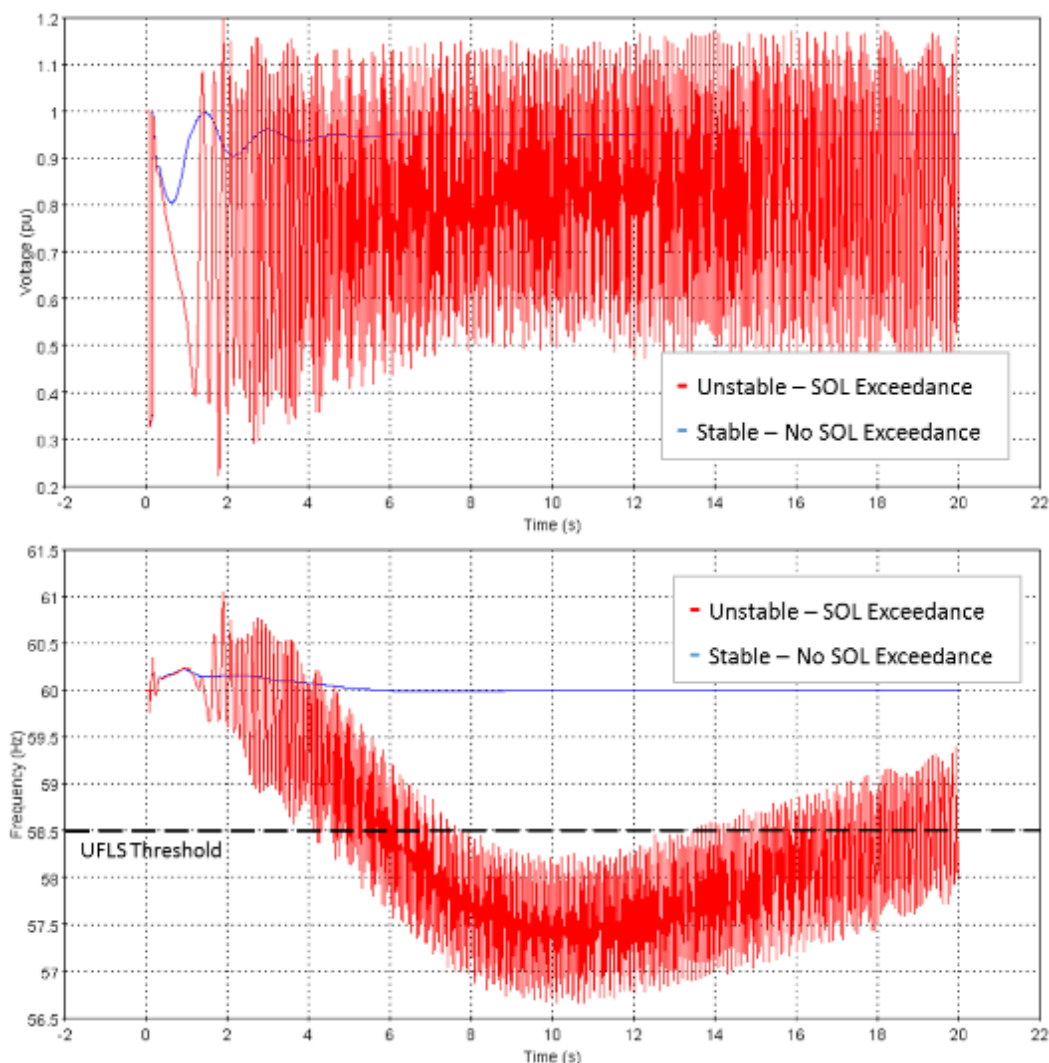

Figure 3.8: EHV Bus Voltage and Frequency for Instability Conditions

[Source: Hydro Quebec]

Generic models for generator protection (e.g., GNSCN1 out-of-step unit tripping model in this case) were included in the dynamic model and the simulations were rerun. Once generator protection is modeled, the simulations clearly show the sequence of plant instabilities that lead to a diverged dynamic simulation (see [Figure 3.9](#)). Three generator tripping events are detected and the system quickly reaches system instability within one or two seconds following the final tripping.

The simulation results are unable to quantify the size and/or containment of the instability and therefore this instability should be deemed system instability. An IROL should therefore be established to mitigate this system instability.

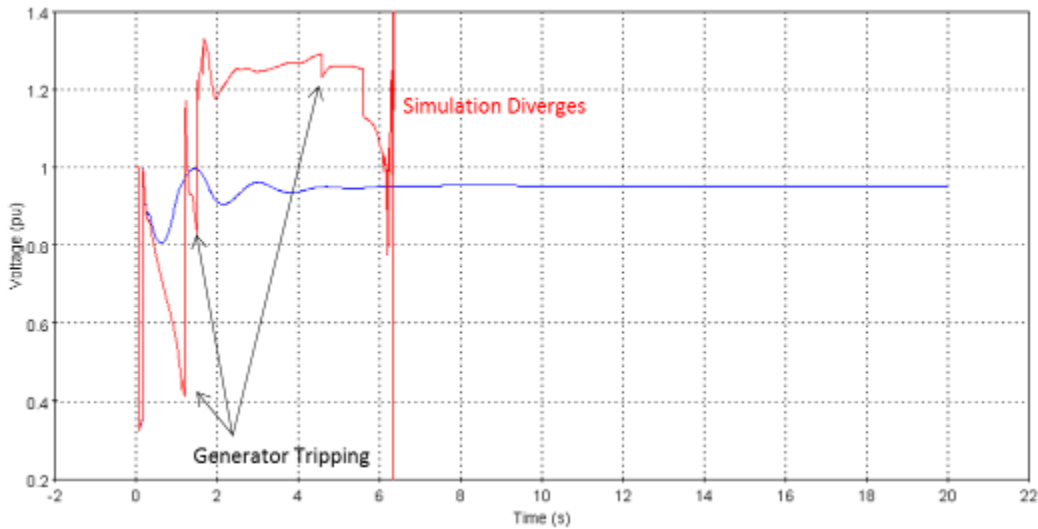

Figure 3.9: Identification and Impact of Generator Tripping Leading to System Instability
 [Source: Hydro Quebec]

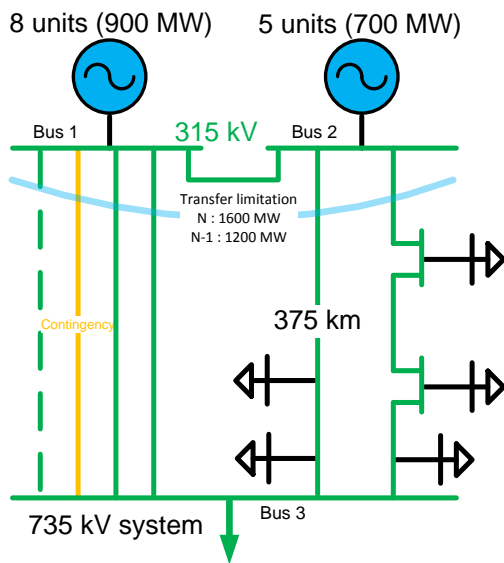

Figure 3.10: Radial Generation Subsystem Subject to Rotor Angle Instability Example

Figure 3.10 shows a 315 kV subsystem comprised of generating units subject to rotor angle instability due to long interconnected transmission lines. Several load substations are connected along the lines between Bus 2 and Bus 3. Some substations also include small generating plants (e.g., < 50 MW). Assuming the planned removal of a transmission line between Bus 1 and Bus 3 for maintenance, the most limiting contingency is a three-phase normally cleared fault, resulting in the outage of the faulted transmission line between those buses. With an instability identified and an SOL established, the question arises as to whether the SOL should be considered an IROL.

Figure 3.11 shows the bus voltage magnitude at Bus 1 for the simulated contingency at two different transfer levels: 1,200 MW (the actual system limit) and 1,300 MW (unstable case). For the unstable scenario, the 315 kV voltage at Bus 1 shows a clear instability of one or more generating units (severe oscillations in the voltage due to pole slipping in the simulation). Observing the voltage on the main EHV system shows acceptable yet oscillating bus voltages (see Figure 3.11). The simulation does not diverge and subsequent analysis can be performed.

The oscillations can also be observed in the system frequency signals (see Figure 3.12); however, the “average frequency” from the oscillating signal shows a resulting frequency that is consistent with the loss of the unit(s). Still, OOS conditions are confirmed by analyzing the rotor angle deviation of the individual units relative to the main grid (see Figure 3.13).

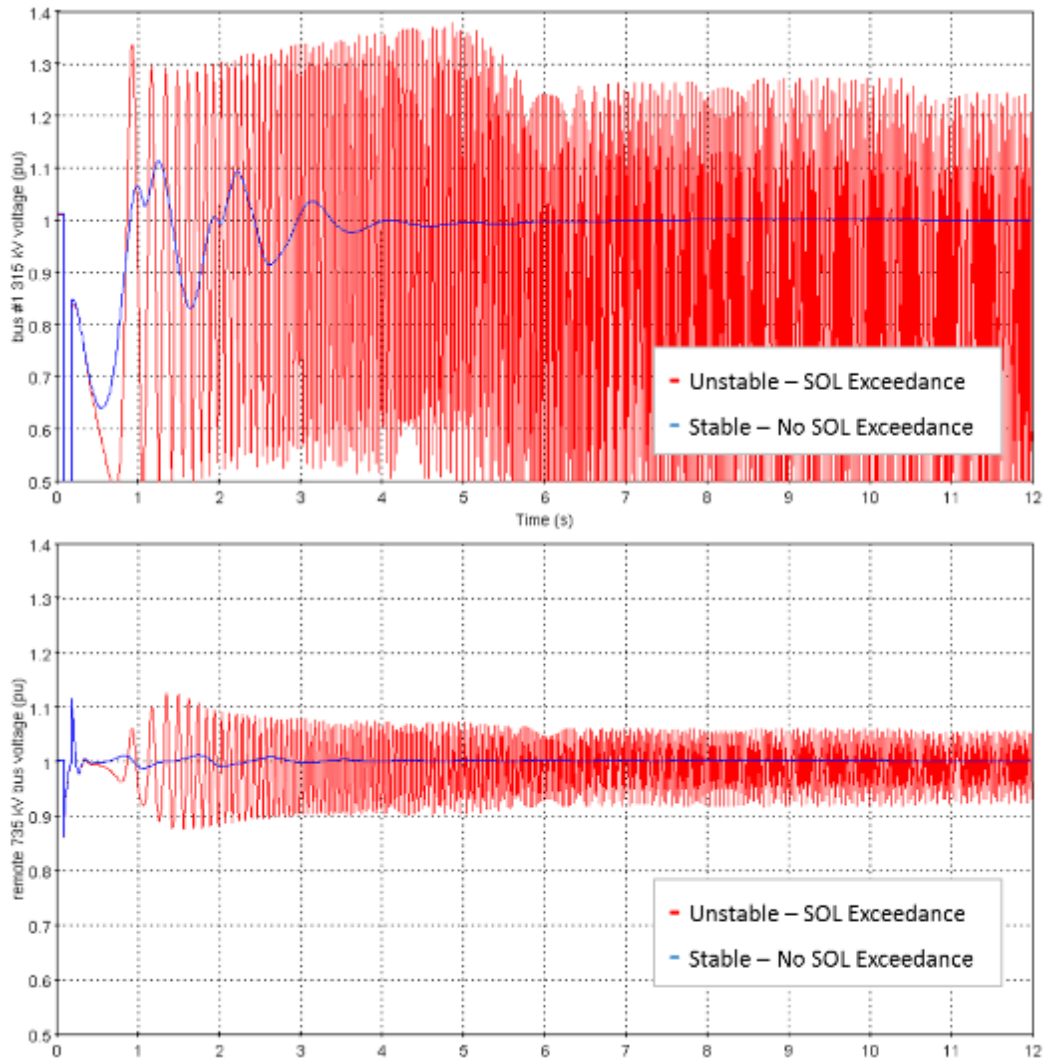

Figure 3.11: Local and Remote Bus Voltage Magnitude for Stable and Unstable Conditions

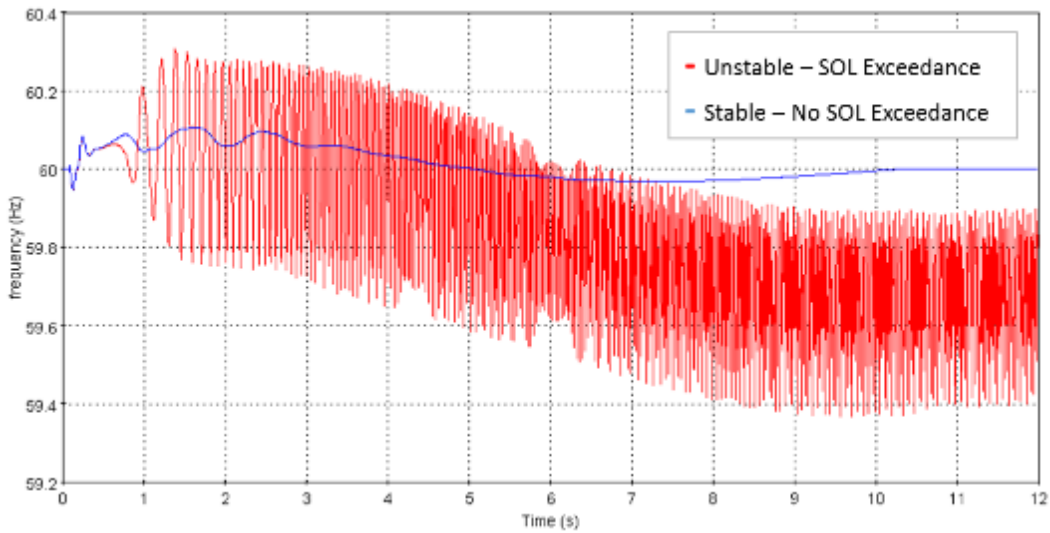

Figure 3.12: System Frequency for Stable and Unstable Conditions

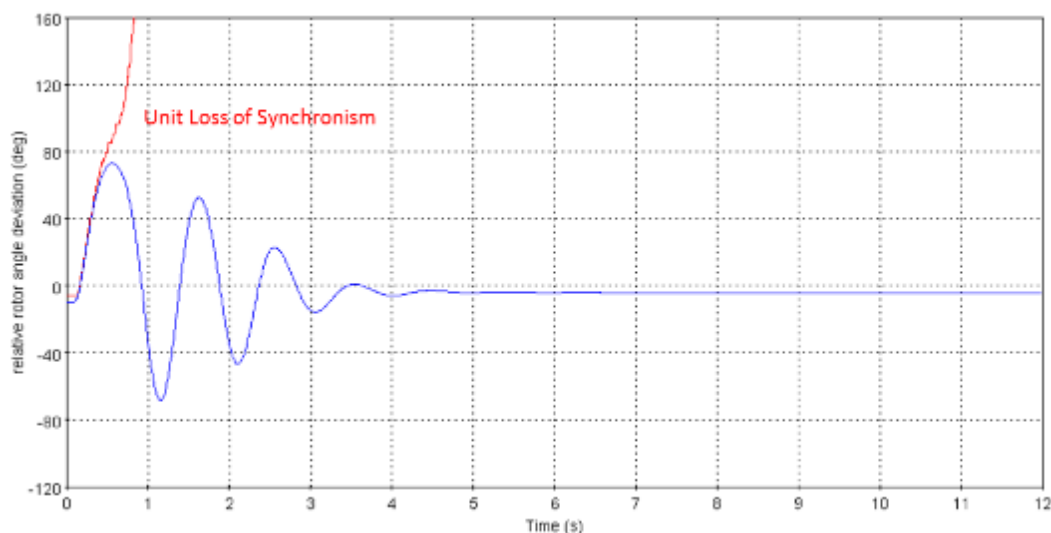

Figure 3.13: Rotor Angle Deviations for Stable and Unstable Conditions

At this point, the simulations clearly show instability, yet the results are not clear or conclusive in quantifying the breadth or impact of the instability. These impacts should consider if the following is the situation:

- The rotor angle instability is limited to the units in the subsystem being studied
- The consequences of the instability (e.g., bus voltage magnitudes) affects reliability of the rest of the BPS outside the subsystem
- The tripping of the unstable generating units causes further adverse impacts on the BPS

Actual or generic protection settings need to be represented in the simulations to analyze the effect of tripping the unstable units or the affected transmission system elements. The assumptions on tripping conditions need to be reasonably verified. **Figure 3.14** and **Figure 3.15** show the frequency and bus voltage magnitude, respectively, for the unstable cases. The red plots show the instability simulations results with generic OOS protection modeled using GNSCN1 (with the monitor and trip mode). The GNSCN1 was set to trip the unit once its rotor angle exceeded 180 degrees from the average system frequency value. The simulation results show that tripping the generators with OOS conditions by using the generic relays eliminates the unstable condition. The BPS experiences a dynamic event; however, bus voltages stably return to within acceptable limits and frequency does not exceed any UFLS thresholds from the resultant tripping of generation and load due to the instability.

However, the unstable conditions of the identified generators and resulting voltage swings caused by this instability may potentially cause the tripping of transmission elements' protection, especially for the circuits adjacent to the subsystem being affected. The next step to prove containment of the instability is to model the transmission protection using either generic or actual settings. The blue plots in **Figure 3.14** and **Figure 3.15** show the simulation results with the addition of the OSSCAN that monitors and trips transmission elements susceptible to trip under OOS conditions. The OSSCAN model operates before the generic generator OOS protection resulting in the tripping of all remaining transmission lines between Bus 1 and Bus 3 as well as some line segments between Bus 2 and Bus 3. This separates the units from the rest of the BPS due to line tripping on angular swings. Those units are then tripped by the generic OOS relays. The tripping of transmission lines causes a (quantifiable) small loss of load on tapped substations, explaining why the frequency traces are not nearly identical.

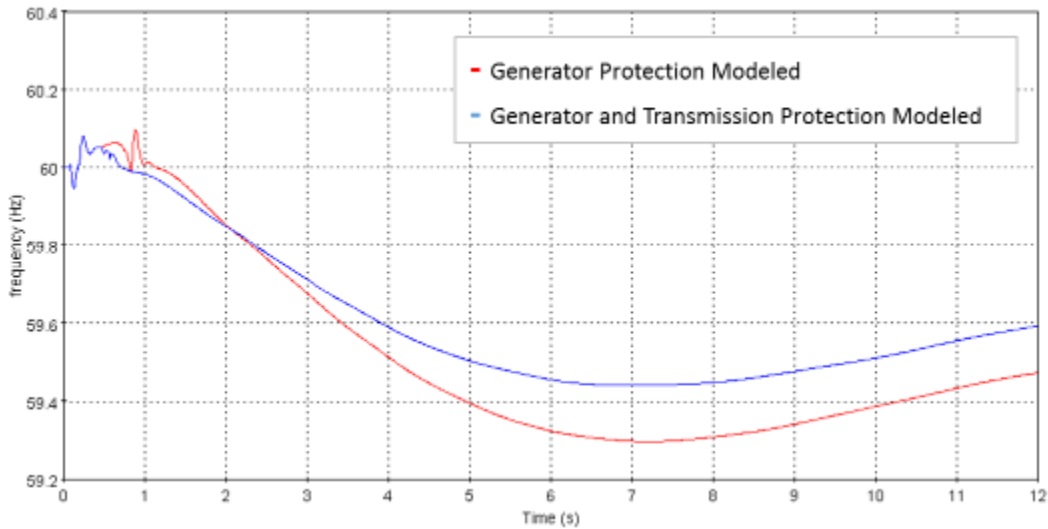

Figure 3.14: System Frequency with Generic Generator and Transmission Protection Models Included

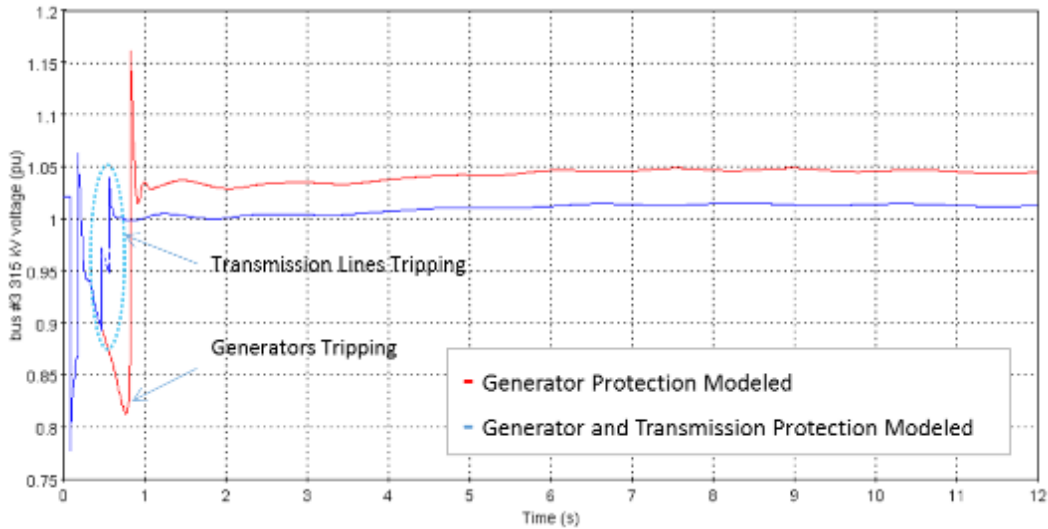

Figure 3.15: System Voltage with Generic Generator and Transmission Protection Models Included

In this case, the instability is quantifiable, the loss of load is within acceptable limits, and the instability is not considered system instability. An IROL should not be established for this stability limit; however, an SOL would be established to ensure Reliable Operation.

Key Takeaways: Rotor Angle Instability Assessment Techniques

The impact that rotor angle instability has on the BPS can be assessed to some reasonable degree, assuming the following considerations are made:

- Simulations with a unit remaining out of step should not be used to assess the impact or boundary of instability. If there are any numerical instability issues that would degrade the integrity of the simulation results.
- Protection should be modeled to understand how any unstable unit is expected to be removed from service dynamically (e.g., via its own protection).
- Transmission protection, particularly in the vicinity of the unstable generator(s), should be modeled to demonstrate that the impact on local transmission elements is well understood and planned ahead of time.
- The concept of unit instability can also be applied to groups of generators or generation centers that may lose synchronism for specific contingencies.
- The amount of generation, load, and system elements should be considered when assessing the impact of instability. Instability that results in transmission element tripping or load loss should generally be warrant establishing an IROL unless known and expected based on studies.
- Instability that cannot be sufficiently proven via study to be contained to a pre-determined area should be identified as system instability. In these cases, simulation results are inconclusive as to the extent or impact that Instability may have on the BPS.

Small Signal Instability Assessment Techniques

Small signal stability, according to the IEEE/CIGRE definition, represents the inherent ability of the power system to maintain synchronism under small disturbances. When the system enters into an operating state where small signal stability cannot be maintained, small disturbances or system condition variation, such as load ramping, generation redispatch, and equipment switching may invoke localized or wide-area instability (typically growing rotor angle oscillations without sufficient damping torque). Unlike other types of stability issues, the existence of small signal instability (SSI) does not have to result from occurrence of contingency events. On the other hand, the SSI modes involved in the unstable behavior are functions of system conditions, topology, disturbance scenarios, etc. **Figure 3.16** illustrates the process of screening potential SSI, and this section briefly introduces the techniques used for IROL/SOL classification purposes.

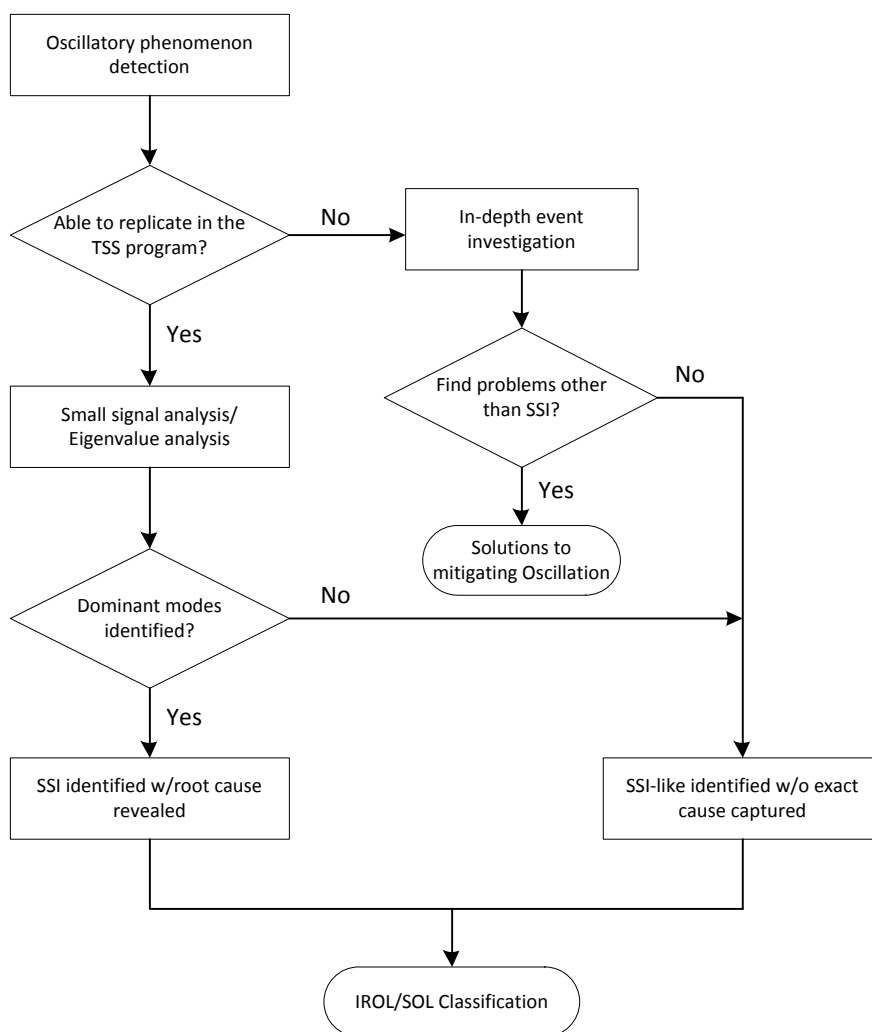

Figure 3.16: Small Signal Instability Screening and Assessment Process

Detection of Oscillatory Phenomenon

When small signal instability exists in an operating state, unstable modes cannot be effectively depressed due to insufficient damping torque and start moving away from their original equilibrium point once perturbed by small disturbances. Consequently, electrical quantities and system states (e.g., bus voltages, rotor angles) will exhibit unstable performance, such as poorly damped oscillations. Sustained oscillations, if not mitigated, may continue to grow and eventually result in severe voltage fluctuations, voltage collapse, generator tripping, load loss, or uncontrolled separation.

Historical system disturbances as well as many simulation studies have demonstrated that unknown sustained oscillatory phenomenon ranging from < 1 Hz to a few Hz can be a strong precursor of certain SSI modes being excited. Therefore, monitoring and detecting abnormal oscillation phenomenon in an effective and timely manner is critical in capturing potential SSI in the system.⁴⁷ Success in detecting abnormal oscillations in the system warrants further event investigation and SSI assessment. [Figure 3.17](#) and [Figure 3.18](#) show examples of sustained or poorly damped oscillations in actual system operation and in transient stability study simulations, respectively.

⁴⁷ See the NERC Reliability Guideline on *Forced Oscillation Monitoring and Mitigation* for more information on detection and identification of power system oscillations. Available: [HERE](#).

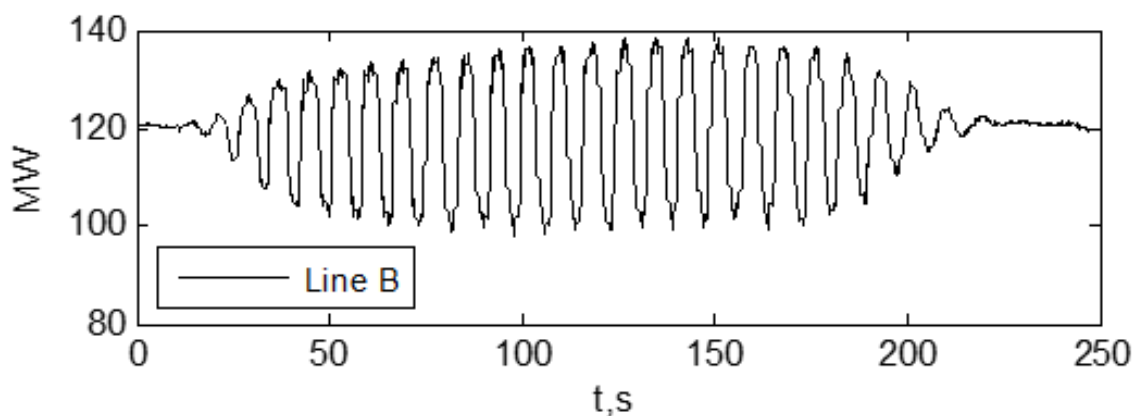

Figure 3.17: Oscillatory Phenomenon Detected on Actual System

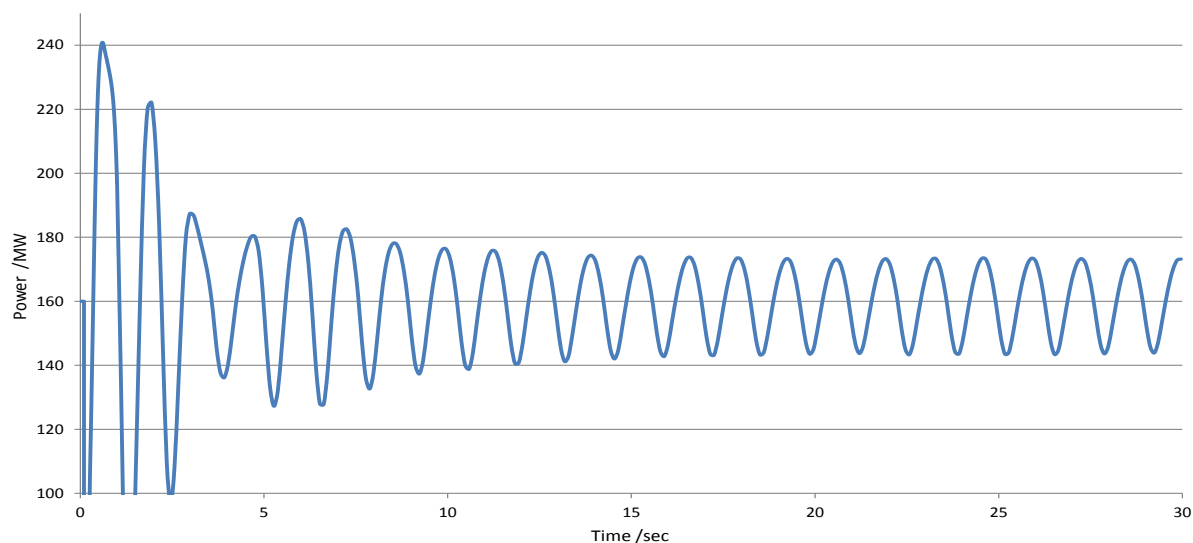

Figure 3.18: Oscillatory Behavior in Transient Dynamic Simulation

Event Replication in a Transient Stability Simulation Program

After oscillations are detected, confirmed, and preliminarily concluded to be SSI-related, replication of the event in a transient stability simulation program is key before moving to more detailed small signal analysis (SSA) studies. The importance of event replication in transient stability simulations includes the following:

- Successful replication ensures that the dynamic models representing the actual power system have sufficient accuracy up to the level to contain potential unstable modes that has been observed. This verifies that the dynamic models can be readily used in the SSA tools for further eigenvalue analysis.
- Replication by simulation also helps check some of the case static models that also play important roles in forming the potential SSI modes. These models include, but are not limited to, system demand level, generation dispatch, grid topology, etc. The idea is to match the study case to the actual system conditions at the time of the event as closely as possible.

Some challenges and limitations in accomplishing event replication include the following:

- Dynamic model accuracy in impacted areas (particularly for power plants—generator, excitation system, PSS, and governor) plays a critical role in successfully replicating the event. If the corresponding dynamic models are not sufficiently accurate, benchmarking may be necessary.

- The closer the steady-state powerflow matches actual system conditions, the more accurate the event replication in a transient stability simulation will be. The real-time snapshot from the EMS model should be mapped to the TSS program either automatically or through manual analysis (which may be challenging).
- In some situations, the event details and other external information are not well understood; therefore, discrepancies between modeling approaches, and modeling errors, may lead to no match.

Eigenvalue Analysis and Instability Investigation

Assuming the oscillation event can be replicated in the transient stability simulation, small signal analysis (eigenvalue analysis) using SSA tools can be applied (assuming verified models are available). Typically, users prepare the steady-state and dynamic models for analysis, and the SSA software performs the detailed mathematical derivations. The user then analyzes the results to determine potential instability conditions. Understanding the fundamental concepts of SSA is important to comprehending the SSA results generated.

The general philosophy in determining IROL or SOL classification for an affirmative SSI or a potential SSI-like reliability risk (after going through SSI screening and assessment process) relies on the following considerations:

- Localization and boundary of impacted area
- The potential amount (MW) of generation or load loss in impacted area
- The potential consequence of a separation of the impacted area from the remaining system
- Any potential unnecessary protective relay actions and associated cascading
- Any potential negative impact or damage to power system equipment due to sustained SSI

Given a potential SSI concern, each RC should use engineering judgment in assessing the potential consequences and associated reliability risks based on past experience and their system operational characteristics.

Eigenvalues and Eigenvectors

A non-linear control system like a typical power system can be approximated by linearized state-space equations (as in (1)) around the equilibrium point. The solution of these equations can represent state movement within that small region.

$$\begin{bmatrix} \dot{x}_1 \\ \dot{x}_2 \\ \vdots \\ \dot{x}_n \end{bmatrix} = \begin{bmatrix} a_{11} & a_{12} & \dots & a_{1n} \\ a_{21} & a_{22} & \dots & a_{2n} \\ \vdots & \vdots & \ddots & \vdots \\ a_{n1} & a_{n2} & \dots & a_{nn} \end{bmatrix} \bigg|_{x=x_0} \begin{bmatrix} x_1 \\ x_2 \\ \vdots \\ x_n \end{bmatrix} \quad (1)$$

$X = [x_1, x_2, \dots, x_n]^T$ is the state variable vector and the A matrix represents the constant system state matrix. By solving $\det(A - I\lambda) = 0$ and $A\phi = \lambda\phi$, the n eigenvalues $\lambda_1, \lambda_2, \dots, \lambda_n$ and corresponding eigenvectors $\phi_1, \phi_2, \dots, \phi_n$ are obtained. Then the n state variables can be represented by

$$\begin{bmatrix} \vdots \\ x_i(t) \\ \vdots \\ x_j(t) \\ \vdots \end{bmatrix} = \begin{bmatrix} \vdots \\ \phi_{i1} \\ \vdots \\ \phi_{j1} \\ \vdots \end{bmatrix} c_1 e^{\lambda_1 t} + \begin{bmatrix} \vdots \\ \phi_{i2} \\ \vdots \\ \phi_{j2} \\ \vdots \end{bmatrix} c_2 e^{\lambda_2 t} + \dots + \begin{bmatrix} \vdots \\ \phi_{in} \\ \vdots \\ \phi_{jn} \\ \vdots \end{bmatrix} c_n e^{\lambda_n t} \quad (2)$$

where c_1, c_2, \dots, c_n are constants determined by the equilibrium point x_0 . Each time dependent item $e^{\lambda_i t}$ that contains a particular eigenvalue determines a single mode characteristic, the sum of them represents the final combined mode characteristics. More specifically, a real eigenvalues corresponds to a non-oscillatory mode. Complex eigenvalues that always occur in conjugate pairs correspond to a particular oscillatory mode as $\lambda_{1,2} = \sigma \pm j\omega$, where σ and ω represent mode damping ratio and frequency, respectively.

By computing eigenvalues and eigenvectors, the SSA tool is able to find out each individual mode and then select modes with frequencies close to the ones under investigation for display. The SSA tool also has the functionality of generating metrics to indicate relative activity of a state variable in a particular mode, which is defined as the “mode shape” in many literatures. Then, by capturing state variables with most outstanding mode shape in the targeted unstable modes, the SSA tool can readily locate dynamic equipment that is contributing most to the unstable modes.

Voltage Instability Assessment Techniques

Assessment of voltage instability focuses mainly on determination of its containment and potential impact that the instability may have on the BPS. Voltage instability also deals with the fact that an unstable operating condition (diverged powerflow, transient simulation instability, etc.) leaves the engineer with a base case or simulation result that is unusable to draw useful information from. This section describes the various aspects of voltage instability analysis and identifies the technical issues that should be taken into consideration when conducting these analyses.

P-V Analysis

Steady-state voltage stability analysis often uses P-V curves to determine the maximum allowable power transfer before low voltage or voltage stability limits are reached. Traditional analysis techniques of identifying these points is straightforward. However, the determination of containment and impact is critical if an RC explores whether the

instability warrants establishment of an IROL. It is common to simply identify the nose of the curve (point of instability) as the IROL with no further analysis. If one is to determine whether the instability is contained, then additional steps and considerations should be taken to characterize the voltage instability as localized or system instability.

A P-V curve approaching the voltage stability limit (nose of the curve) will experience degrading voltage conditions, whether in the pre- or post-contingency state. At the nose of the P-V curve, the last powerflow solution is attained (see [Figure 3.19](#)). After this point, the powerflow solution diverges and the results are not usable for analysis of containment. However, there are workarounds and additional analysis techniques that can be used to quantify the extent of the instability. At the powerflow solution prior to the instability point and unsolved powerflow case, bus voltages can be monitored across the affected area. While not the true point of instability, this proxy for instability should demonstrate the affected buses that are unstable and help determine whether a clear and quantifiable boundary can be identified. Situations where a clear boundary is not identified should be considered system instability.

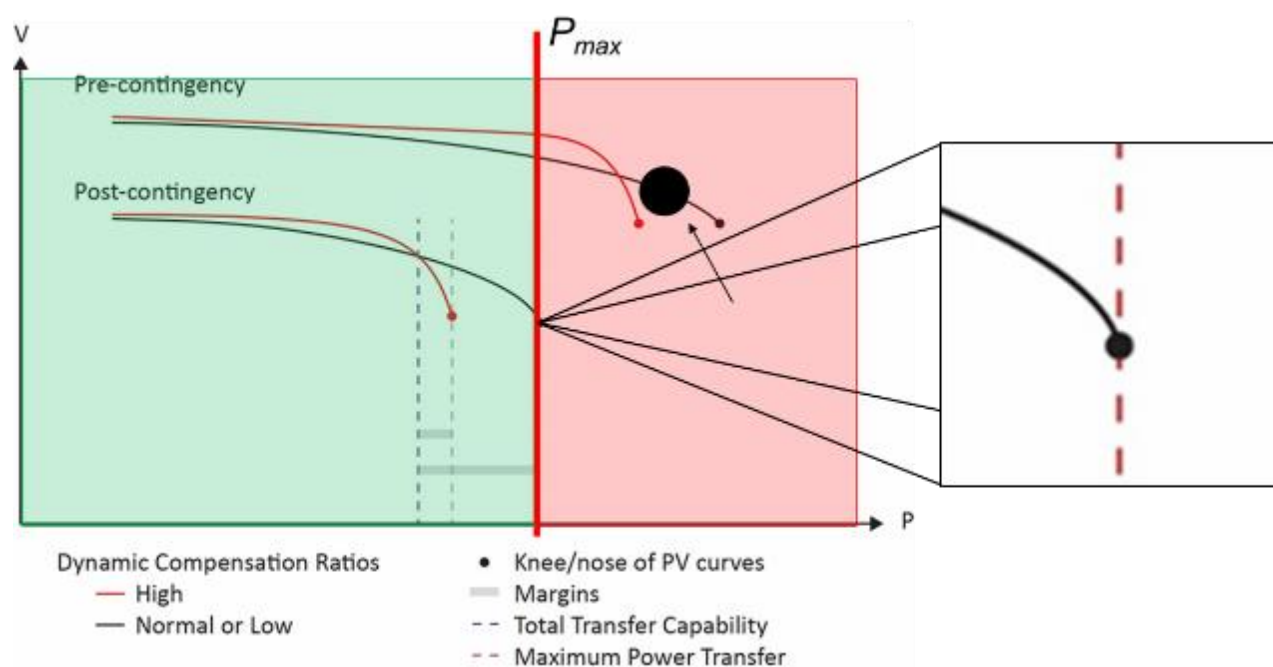

Figure 3.19: Illustration of P-V Curve Point of Instability

Consider [Figure 3.20](#) showing two distinct cases of instability—a localized (left) and a widespread (right) voltage collapse. A localized voltage instability will observe one or a relatively small amount of buses where voltage drops significantly. The remaining buses maintain an adequate voltage level, signifying a relatively strong system that is robust to voltage collapse with the exception of the affected low voltage buses. In [Figure 3.20](#) (left), one bus voltage drops below 0.75 pu at the point of voltage instability. This bus is likely singlehandedly causing the divergence (instability point) in the simulation. All other bus voltages remain above 0.9 pu and are likely not contributing to the instability. A widespread voltage instability experiences significant voltage drop across many buses. Identifying the bus(es) that contribute to the instability becomes a challenge since many buses experience the voltage drop. [Figure 3.20](#) (right) shows an example where many buses coherently drop in voltage up to the point of instability. It is important to note that voltages actually remain relatively high up to the point of collapse.

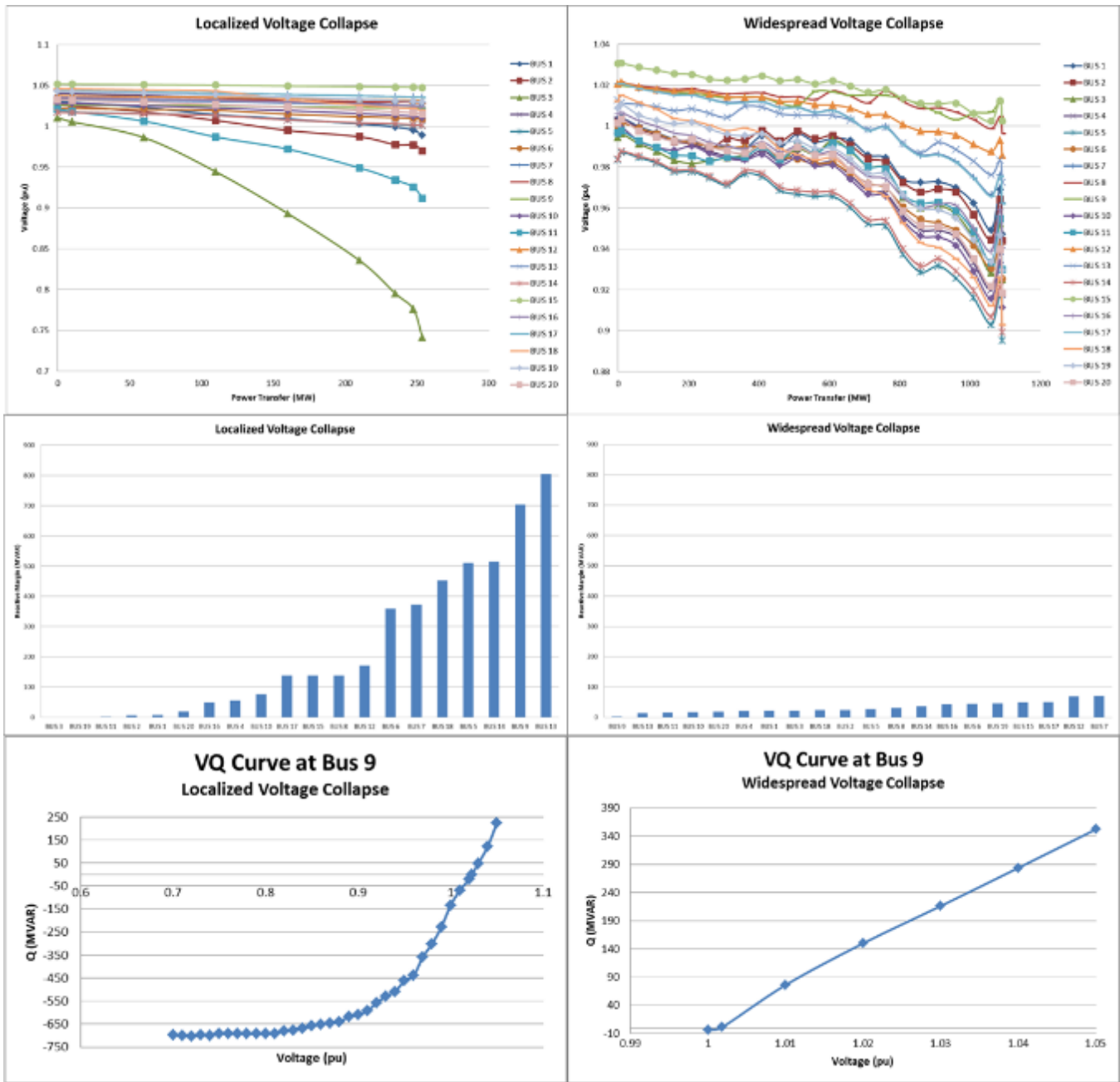

Figure 3.20: Widespread vs. Localized Voltage Collapse

[Source: FPL]

Contingency Analysis

Along with P-V analysis, voltage instability may occur for severe contingencies during steady-state contingency analysis. The analysis of pre- and post-contingency steady-state operating conditions is functionally very similar between the two. A "soft outage" approach may be employed as the analysis approaches the point of instability (nose of the P-V curve) when a contingency causes the powerflow solution to diverge due to voltage collapse (or for potential numerical instability). The nose or collapsing voltage can be visualized to demonstrate whether the instability is localized or widespread. **Figure 3.21** shows an actual BPS load pocket and the voltage contour during a collapsing voltage condition following a contingency. As the "soft outage" is applied, the load pocket is connected through one remaining transmission circuit that is unable to serve the load. The voltages within the load pocket drop significantly while voltages outside the pocket remain near nominal (within acceptable limits).

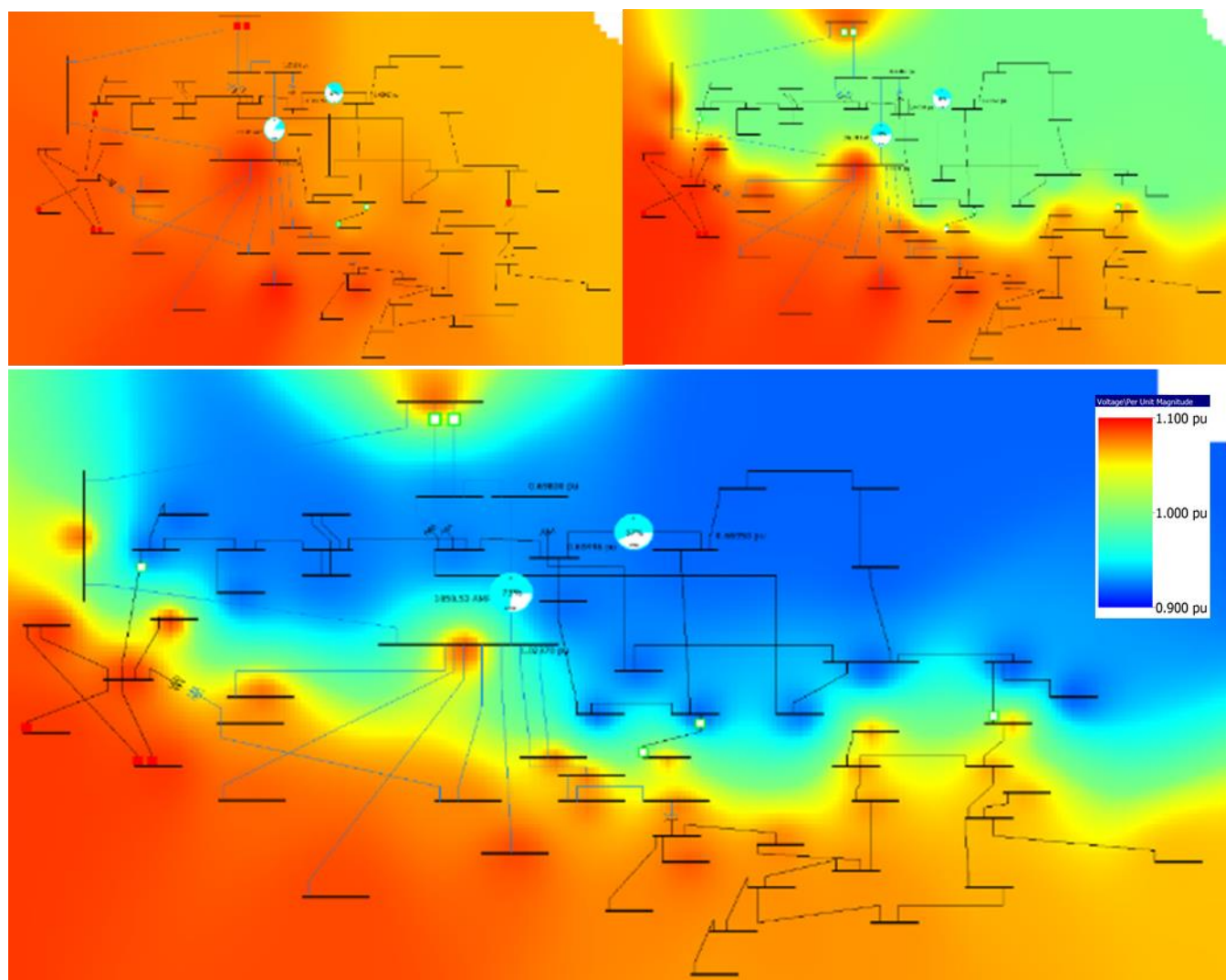

Figure 3.21: Example of Voltage Instability in Local Load Pocket

Demonstrating that the voltage instability is contained should include modeling actual (if available) or generic relay protection to show that the unstable area is reliably disconnected from the rest of the BPS. For the sequence of simulations during the “soft outage,” the apparent impedance as seen by the relay can be recorded and compared with the modeled or assumed protection settings for that respective circuit. If the studied conditions clearly demonstrate relay operation, one can sufficiently justify that the load pocket will be separated in a planned manner. If the operation of protection systems cannot be demonstrated clearly, it is much harder to justify that the instability will be localized.

It is important to note that steady-state power flow models represent the load active and reactive power components as a constant power (i.e., load power does not change for voltage deviations). Around nominal voltage, this assumption holds;⁴⁸ however, as voltages significantly change from nominal, load dynamics are expected to change the consumption in power either upward or downward depending on load type. See the following examples:

- Motor loads could stall at very low voltage during a collapse, consuming large amounts of reactive power

⁴⁸ Some software packages include settings that automatically adjust load levels at PQ buses based on severely low voltage to relax the powerflow solution (i.e., improve numerical stability of the powerflow solution). However, engineering judgment should be used to set those thresholds below expected collapsing voltage conditions for these types of studies.

- Motor loads could trip at very low voltage due to process controls or contactors dropping out
- Power electronic loads may disconnect based on programmed low voltage settings

This is important because the constant power assumption may, in many cases, result in a diverging powerflow solution near the collapse point that does not exhibit sufficient current to render an apparent impedance seen by a protection system that would be sufficient to trip that relay. In these cases, options exist for further analysis. One option is parametric assessment of the voltage sensitivity of the loads at very low voltage (near collapse point). This includes making assumptions about load dynamics and load consumption at each iteration (based on engineering judgment and a load model representation) of the powerflow solution as the “soft outage” approaches the edge. Another option commonly used is to demonstrate protection system operation using a dynamic simulation where a more detailed load representation, including load dynamics, is taken into consideration. The apparent impedance for the remaining line connecting the collapsing load pocket to the rest of the BPS is analyzed as the collapse occurs. **Figure 3.22** shows the apparent impedance seen by the remaining line utilizing the powerflow “soft outage” techniques by relaxing the powerflow solution. As the impedance trajectory for the line failed to enter into one of the zones of protection, a dynamic simulation of the system was performed. **Figure 3.23** shows the dynamic simulation for the example shown in **Figure 3.22**.

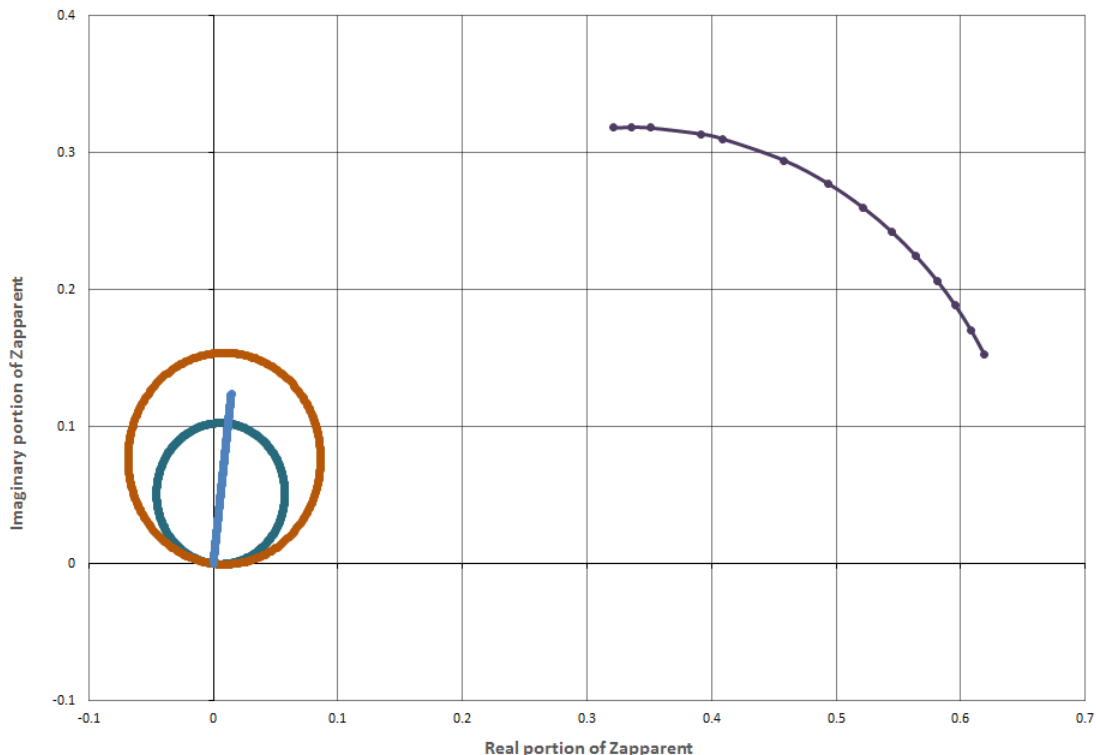

Figure 3.22: Apparent Impedance of Powerflow “Soft Outage” Technique

In this same example, the bus voltages were demonstrated to be in a collapsed region in **Figure 3.22** and the apparent impedance of the remaining in-service line was plotted in the dynamic simulation in **Figure 3.23**. As the dynamic simulation approaches the point of collapse, the powerflow solution begins to demonstrate instability. The apparent impedance plot again is the determining factor of whether protective relays will operate. Since the apparent impedance did not enter the relay zone of operation, the voltage collapse in the example is considered widespread. Voltage collapse is proved contained when the apparent impedance trajectory enter the zones of protection, demonstrating operation of protective relaying (see example in **Figure 3.24**). That is, protective relaying will separate

the unstable load pocket from the rest of the BPS in a reliable manner. The amount of load impacted by the localized instability should still be tracked to determine if an IROL should be established.

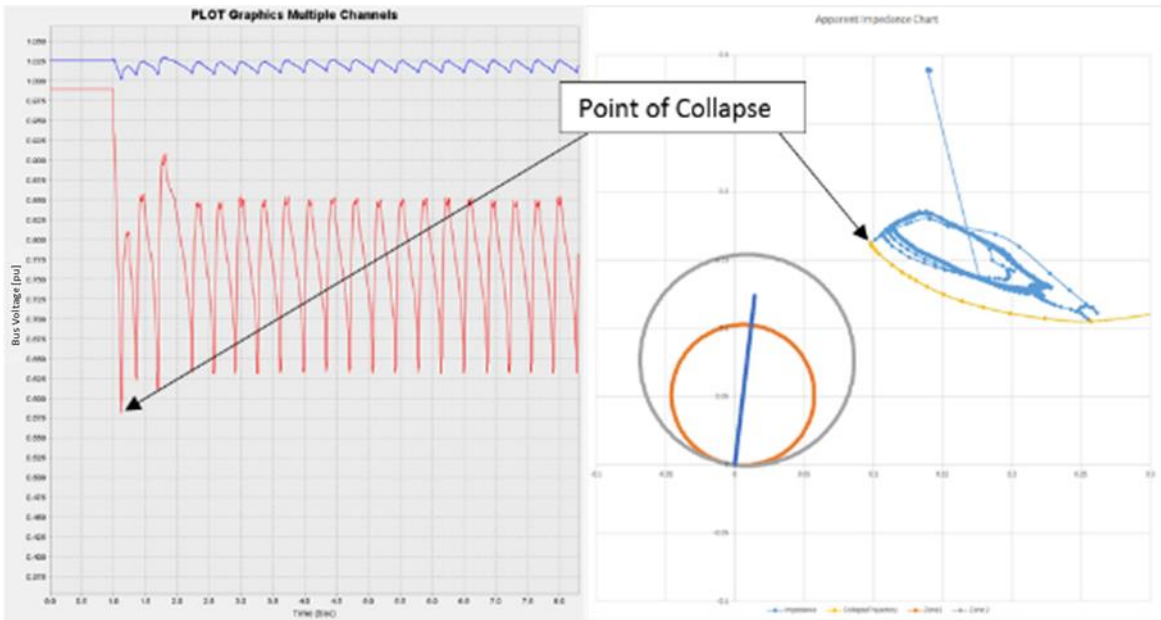

Figure 3.23: Dynamic Simulation Voltage Collapse and Apparent Impedance

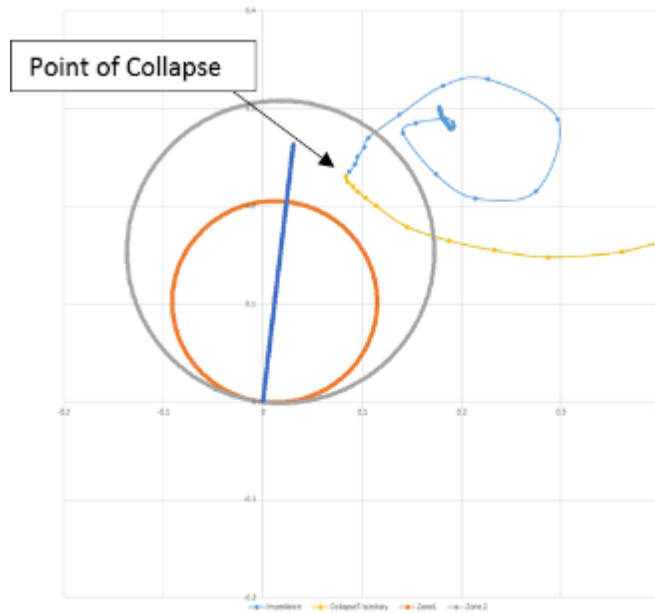

Figure 3.24: Apparent Impedance Trajectory for Higher Impedance Circuit

Mid-Term Voltage Instability Analysis

Mid-term voltage stability analysis takes into consideration the longer-term dynamics that occur after the initial transient voltage stability concerns due to power system oscillations and recovery from the fault conditions. **Figure 3.25** shows an illustrative example of a mid-term voltage stability analysis. The first 20 seconds show the transient voltage stability that recovers properly following a contingency. In this case, an SOL or IROL is used to solely address that transient stability phenomenon. After 30 seconds, on load tap changers (OLTC) take action to control the voltage at the load with a detrimental effect on the transmission level voltage. The action of a few automatic switching shunt reactors being disconnected to maintain the system voltage can also be observed. While the red plot shows a stable

condition at the end of the mid-term simulation (420 s), the blue plot shows a voltage collapse on the high-voltage grid near the load centers. This voltage collapse can be shown to propagate to all neighboring buses, eventually leading to a simulation divergence and clearly unstable system conditions that warrant the establishment of a different IROL to monitor the corresponding transfer interface for longer term voltage dynamics that depends on the status of different equipment. For example, the IROL value related to the transient stability phenomenon is influenced by the status of SVCs and availability of fast acting generation rejection RAS. The IROL value used to address longer term voltage dynamics also depends on the availability of automatic shunt devices.

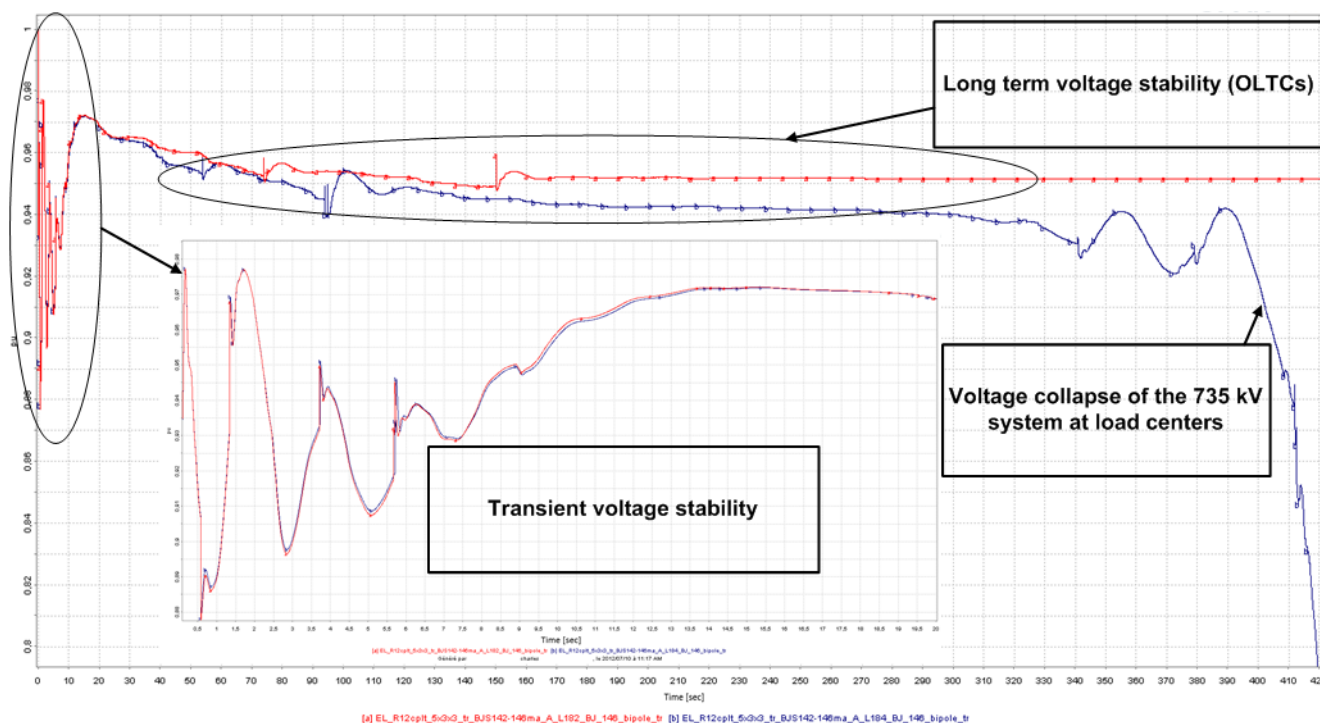

Figure 3.25: Mid-Term Voltage Instability Example

[Source: Hydro Quebec]

Voltage instability could also be demonstrated by simulation to be contained and localized to a planned area of reasonable size and impact. **Figure 3.26** shows an example of a 315 kV system feeding a local 120 kV subsystem with ~450 MW hydro generation and ~1100 MW peak load. The mid-term voltage stability assessment shown in the time domain simulation illustrates how the voltage collapses due to OLTC action and other mid-term dynamics control actions following the loss of a transmission line. Within the subsystem, the 120 kV and 315 kV system voltages drop to unacceptable levels to appropriately serve system load while the source 735 kV system voltage remains within normal operating range, close to the pre-contingency value. The associated P-V curves show the pre- and post-contingency operating states and corresponding operating limit (SOL). In this scenario, exceeding the SOL would cause the post-contingency operating point (in steady-state) to be past the nose of the P-V curve, leading to depressed voltages and potential instability. However, the time domain simulation shows that the severely low voltage does not cause a divergent powerflow case due to the load response, and the assessment can be used to identify a clear boundary, if any. In addition, modeling of transmission protection systems, any on-line UVLS programs, load response to low voltage, and other relevant characteristics should be considered in these studies to demonstrate how the system will behave under the impending voltage instability condition. For example, for the illustrated system, UVLS are installed at several substations as a safety net to mitigate a potential voltage collapse. Under normal operation, an SOL would be established to limit the power transfer to the subsystem without considering the use of UVLS action, but it should not be considered as an IROL since

- The instability can be proved by study to be contained, including appropriate modeling of generator and transmission protection as applicable; and
- The loss of generation and/or load is within the acceptable criteria defined by the RC.

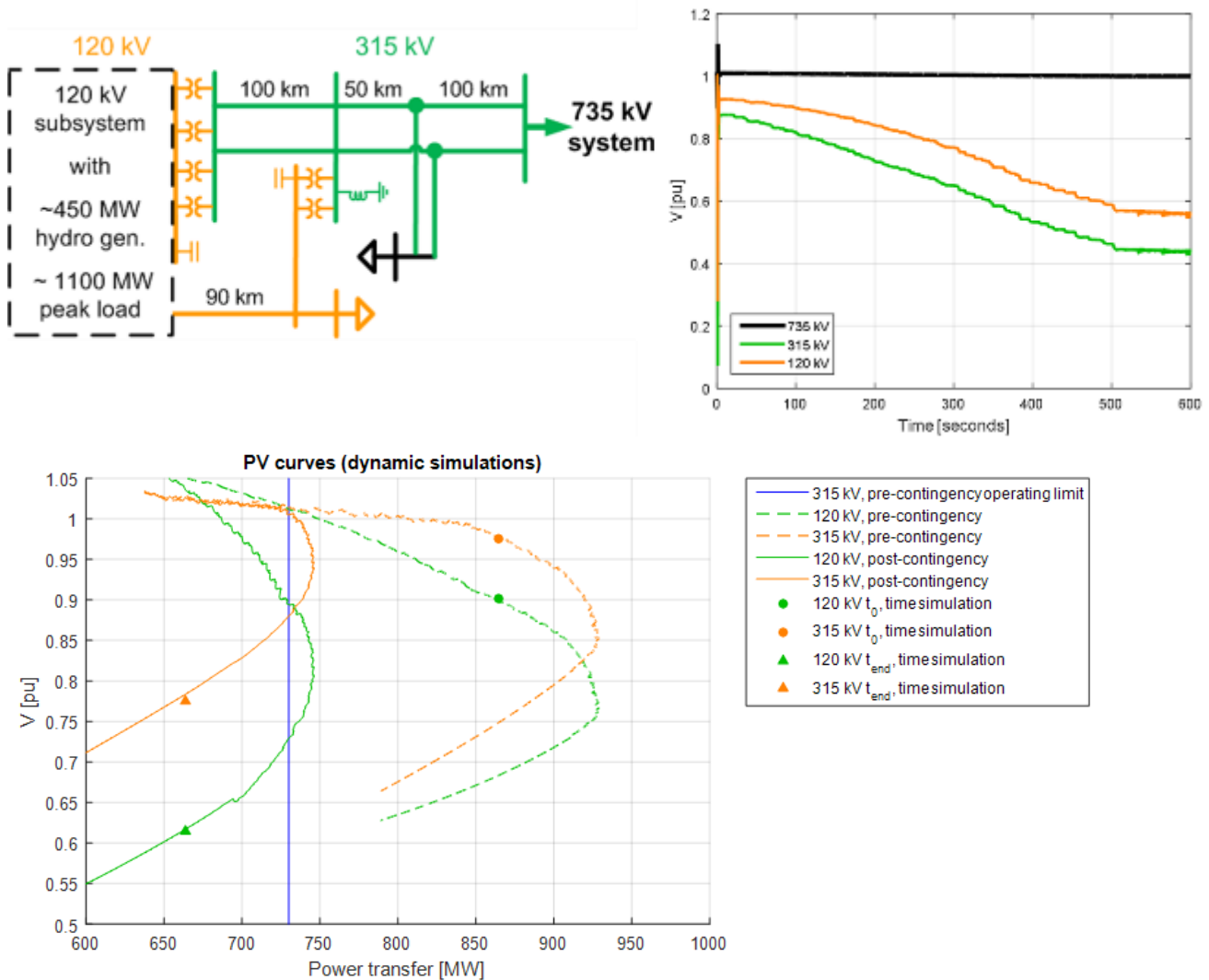

Figure 3.26: Example of Localized Mid-Term Voltage Instability

[Source: Hydro Quebec]

Transient Voltage Stability Analysis

The use of transient voltage response criteria is a good practice for transient voltage stability assessment. Following a disturbance, voltage may swing above and below a certain value that could be critical to the conclusion of the analysis. First, a good proportion of power system devices may present a different dynamic behavior outside a certain voltage range, sometimes not captured by simulation models. Second, protection schemes of transmission elements and equipment could be actuated at certain thresholds. Making sure the system voltage remains outside those thresholds simplifies further analysis that would be required to assess cascading, controlled versus uncontrolled separation, etc. Finally, depending on system characteristics, violation of certain voltage thresholds during transient swings can be an accurate sign of an imminent unstable condition. Relying on adequate voltage response criteria can thus be a way to provide system limits the desired margin for adequate reliability.

Figure 3.27 shows an example of transient voltage swing following a given contingency for various transfer levels. The purpose of such simulations is to progressively stress the system to the point where voltage criteria are reached

and then to find the point of insecure or unstable state. For this system, the voltage criteria corresponds to 0.8 pu for the first swing following a disturbance (first two seconds) and 0.9 pu for transient stability recovery. This ensures adequate behavior of the dynamic models, gives a good level of confidence regarding the operation of undesirable protection schemes that could lead to uncontrolled separation or cascading, and more importantly, it prevents the system from reaching a point of instability. The red plot shows the transfer level for which voltage starts to oscillate past the acceptable criteria while recovering well into acceptable range afterwards. For this case, since the monitored bus shows the worst voltage dynamics and all other buses are within the acceptable criteria, it is used as the most limiting case to address the SOL and associated IROL when relevant.

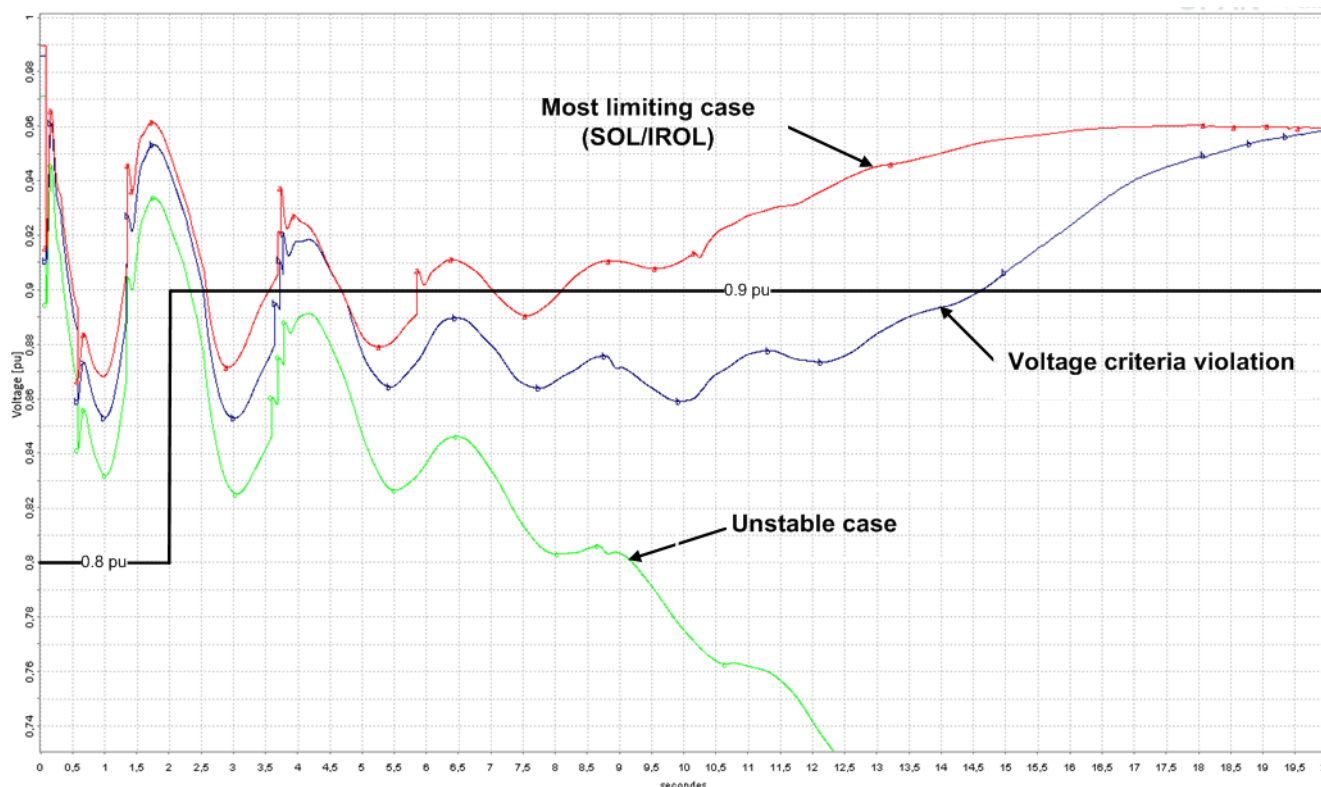

Figure 3.27: Simulations of Transient Voltage Instability

[Source: Hydro Quebec]

Increasing the power transfer beyond the established limit for this example quickly leads to prolonged and unacceptable undervoltage conditions that could cause tripping of equipment (blue plot) and eventually fast voltage collapse as shown on the green plot for which voltage never recovers. [Figure 3.32](#) in the following section on frequency instability analysis shows the corresponding frequency that confirms system instability and warrants the establishment of an IROL. The occurrence of the worst contingency while exceeding the SOL could indeed cause system instability affecting the whole interconnection.

Frequency Instability Assessment Techniques

Frequency stability of an interconnected power system is typically assessed through the use of dynamic simulations by using the same models used for transient stability analyses. The contingency results in a significant generation/load imbalance on the system, causing a severe deviation of frequency. The initial condition to which contingencies are applied should represent a projected system condition of risk (e.g., low inertia scenario where the system is most vulnerable to a frequency event). Typically, these simulations are run for up to 30–60 seconds to reflect the impact of inertia, frequency responsive loads, generator governor response, and to also avoid the longer-term boiler controls and other thermal aspects not captured with transient stability models.

Generator overfrequency protection is typically not modelled. Therefore, if system frequency in the simulations exceeds a pre-established threshold, then the system is deemed unstable for that contingency under the studied conditions. The threshold is based on generator over-speed protection and ride-through capability (e.g., PRC-024-2 frequency capability curve—see [Figure 3.28](#)). This capability curve is aligned with the objectives and requirements related to the UFLS program design per NERC Reliability Standard PRC-006-2 and other approved regional reliability standards.

Underfrequency load shedding (UFLS) relays may or may not be modeled. Typically, UFLS relays are modeled to study the effects of load shedding relays on the stabilization of grid frequency and islanding. RCs may deem frequency falling below the first stage of UFLS for any contingency that is equal to or less than the Resource Loss Protection Criteria (RLPC) included in Attachment A to BAL-003-1.1 as unacceptable grid performance and establish an IROL. Triggering UFLS should not occur for any contingency smaller than the resource loss protection criteria for each interconnection established in BAL-003-1.1a.

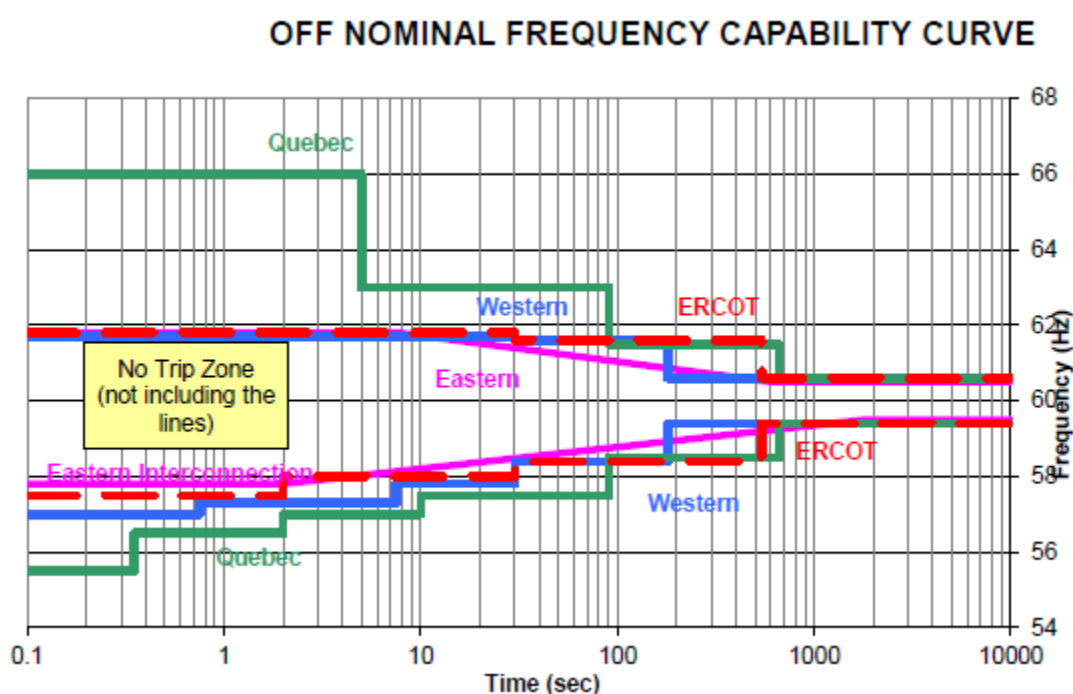

Figure 3.28: PRC-024-2 Off-Nominal Frequency Capability Curve

It is important to consider the various constraints associated with the characteristics of the power system being studied when assessing frequency stability. [Figure 3.29](#) shows the main stages of a typical frequency excursion following a loss of generation. The minimum frequency nadir and rate of change of frequency are dependent on a number of factors, including the amount of generation lost, on-line synchronous inertia, on-line spinning reserve, and speed of primary frequency response from those resources (as well as other fast frequency response). Stage 1 is mainly associated with the inertia (natural response) of the synchronized generation. During that stage, slow speed governors contribute very little to the frequency dynamics. Resources with fast frequency response may start acting during that phase. Stage 2 is when the primary response from synchronous machine governors starts kicking in to help frequency recovery over several dozen of seconds. The dynamics during that period largely depend on the amount of on-line frequency responsive reserve and the number of units providing that reserve. In stage 3, the frequency has stabilized to a new equilibrium that depends on the droop characteristic of the governors, and further frequency adjustment needs to be performed either through an AGC or operator intervention.

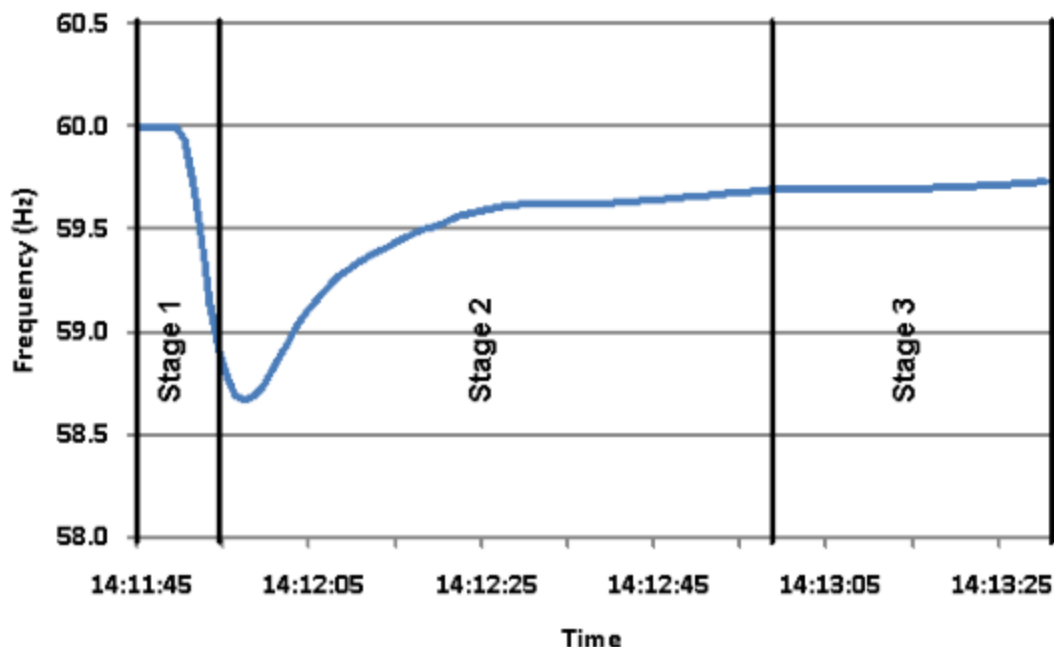

Figure 3.29: Typical Stages of a Frequency Excursion Event following a Loss of Generation

Figure 3.30 shows a very simplified system topology with a subsystem comprising mainly generation (generation subsystem) and a subsystem comprising mainly load (load subsystem). Both subsystems are connected to the main grid through a transmission path for which an SOL (or IROL) could be established to limit the maximum amount of net generation or load that the system can tolerate should a given contingency occur.

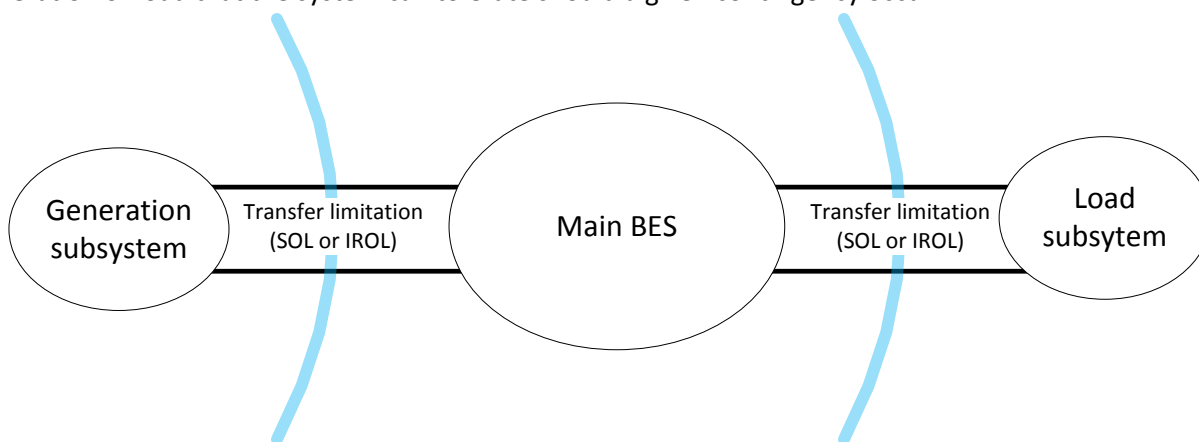

Figure 3.30: Establishing an SOL or IROL to Mitigate the Impact of a Large Loss of Generation or Load

In the context of establishing SOLs and IROLs, frequency stability and frequency response assessment is normally focused on stage 1 and stage 2. For example, Figure 3.31 shows the frequency response of a system following a fixed loss of generation for various spinning reserve and inertia scenarios. The impact of a change in system inertia is mainly reflected by a change in rate of change of frequency (ROCOF) and maximum frequency deviation (nadir). The impact of a change in spinning reserve is mainly reflected by a change in the rate of recovery of the frequency following the nadir and the equilibrium state reached at the end of the simulation. The establishment of an IROL to mitigate the risk of a large loss of generation or load may be justified by the magnitude of the impact on frequency, either by using actual UFLS thresholds or other performance criteria relevant to the system characteristics (e.g., ROCOF, long-term

frequency equilibrium). In this case, the IROL is typically a restriction on the amount of generation output to limit the most severe resource loss contingency. The IROL limit can then be calculated based on system conditions to establish a maximum amount of generation or load that can be lost without affecting system reliability, mainly using spinning reserve, inertia, response time of speed governors, etc. Once an IROL is established to address frequency stability, various means can be used in Operations Planning to provide solutions in limiting the impact of the IROL or reducing the associated constraints. For example, a RAS could be configured to balance the loss of load or generation, the type or amount of primary frequency response reserve could be adjusted or minimum inertia requirements could be imposed for a given reserve scenario.

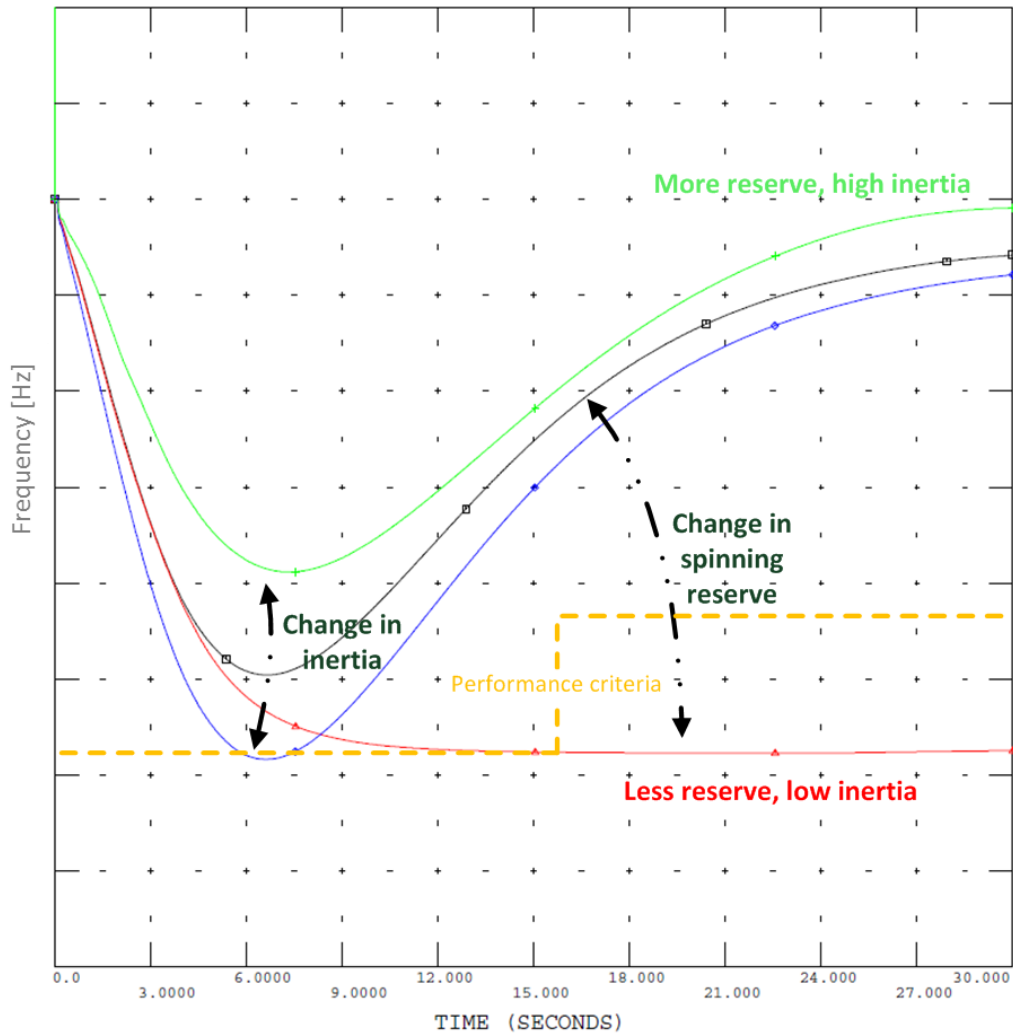

Figure 3.31: Impact of Inertia and Spinning Reserve on Frequency Response following a Loss of Generation

[Source: Hydro Quebec]

Frequency stability is usually related to the analysis of contingencies leading to a net system imbalance (i.e. loss of generation or load), but the system frequency can also be a relevant variable to monitor to assess the impact of transient voltage stability issues. **Figure 3.32** shows the frequency for the transient voltage stability example discussed in the previous section of this document. It shows an overfrequency condition that could be detrimental to BPS reliability, for example, by reaching the capability curve limitations of certain generators. An IROL could thus be established based on this criterion. The same goes for the green plot where the frequency excursion never recovers and confirms the system instability observed on the voltage plots in the previous section.

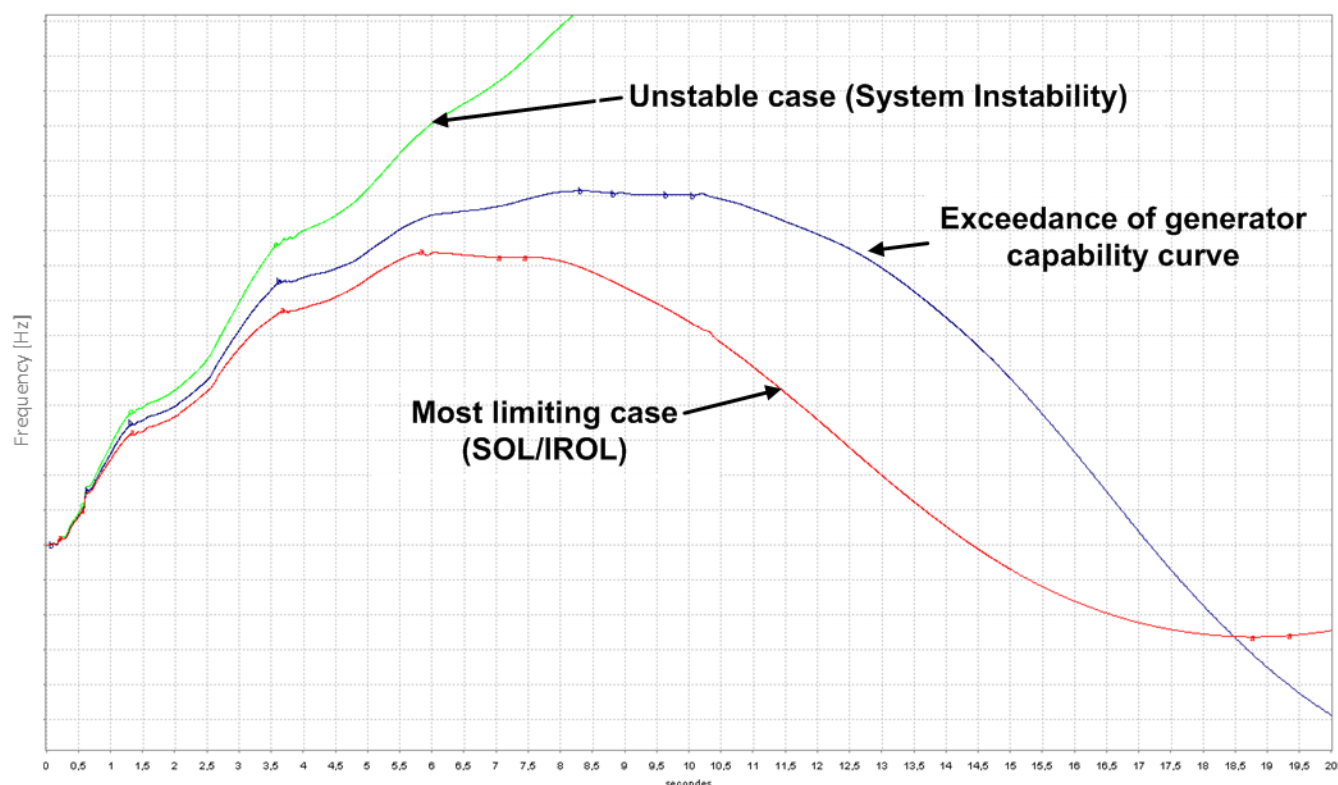

Figure 3.32: Frequency Response following a Transient Stability Event
[Source: Hydro Quebec]

Controls-Related Instability Assessment Techniques

Control instability is primarily a concern in areas where the penetration of inverter-based resources is high relative to system strength. System strength is often described in terms of a short circuit ratio (SCR). However, the SCR calculation is typically used for evaluating system strength beyond a single point of interconnection. To evaluate system strength with respect to a cluster of inverter-based resources connected at multiple adjacent/nearby buses, several techniques have been proposed (e.g., the Composite Short Circuit Ratio (CSCR) and Weighted Short Circuit Ratio (WSCR)).^{49,50} Calculating a system strength index does not in itself identify a risk of instability or controls interactions, but it can be used as an indicator or screening metric of potential instability when supported by time domain simulations.

Typical positive sequence modeling and simulations are inadequate to identify control instabilities under weak grid conditions because the power electronic controls of inverter-based resources are typically not represented in sufficient detail to reflect their behavior under weak conditions (e.g., adequate modeling of a phase lock loop (PLL) control algorithm). Therefore, positive sequence analysis tools alone are not suitable to perform wind and solar integration studies under weak system configurations. In weak networks, transient stability studies should be supplemented with modeling of fast-acting power electronic controllers and assessment of the stability of their operation using an electromagnetic transient (EMT) simulation tool.

EMT simulations can confirm that a calculated system strength index (e.g., CSCR or WSCR) associated with a particular operating condition indicates a stable or unstable operating point; thereby, a threshold with respect to control instability can be determined for each particular plant or system studied. The threshold calculated for one application

⁴⁹ Y. Zhang, J. Schmall, S. Huang, J. Conto, J. Billo, and E. Rehman, "Evaluating System Strength for Large-Scale Wind Plant Integration" Proceedings of 2014 IEEE PES General Meeting, July 27-31, 2014, National Harbor, MD.

⁵⁰ NERC Reliability Guideline on Integrating Inverter-Based Resources into Low Short Circuit Systems.

may not be applicable to another application or different area of the network. In addition, system modifications over time may impact the calculated threshold. Thus, any threshold value should be periodically reviewed with EMT simulations.

For more information regarding integrating inverter-based resources into low short circuit systems as well as details about quantifying system strength, see the NERC Reliability Guideline on *Interconnecting Inverter-Based Resources into Low Short Circuit Systems*.⁵⁰

Subsynchronous Resonance Assessment Techniques

SSR assessment requires more specialized techniques and models than traditional stability analysis. Where as in traditional stability analysis the power system may be assumed at fundamental frequency (near 60 Hz), SSR assessment typically considers frequencies in the subsynchronous range 5 to 55 Hz arising from electro-mechanical interaction of series capacitors with generator electrical, control, and torsional systems. Generator models must also be more specialized and valid for the subsynchronous frequency range. There are three common approaches to SSR assessment: frequency scan (FS), eigenvalue analysis, and EMT time domain simulation.

As an SSR screening method, frequency scan considers the Thevenin electrical impedance of the overall system at a range of discrete frequencies (e.g., from 5 to 55 Hz) and then preliminarily determines SSR vulnerability, including induction generator effects, subsynchronous control interaction, torsional interaction, and torque amplification. Frequency scan can be performed from a variety of vantage points, but most commonly the scan is performed from the perspective of the generator POI. Two scans are usually performed: one looking into the power system and another looking into the generating plant. The scan results are summed to reveal the total system response. Resonant points are identified where the total reactance crosses from negative to positive. IGE/SSCI vulnerability is assessed by inspecting the total resistance at those resonant points. If the total resistance is positive, the system is stable and any subsynchronous oscillations will damp out as shown in [Figure 3.33](#). If the total resistance is negative, the system is unstable and oscillations will grow as shown in [Figure 3.34](#). When studying TI, the FS technique is extended to include the synchronous generator mechanical system by representing frequency scan results on the mechanical reference frame through mechanical and electrical damping. As for TA, the reactance dip of five percent is utilized as a conservative criteria to determine TA vulnerability.

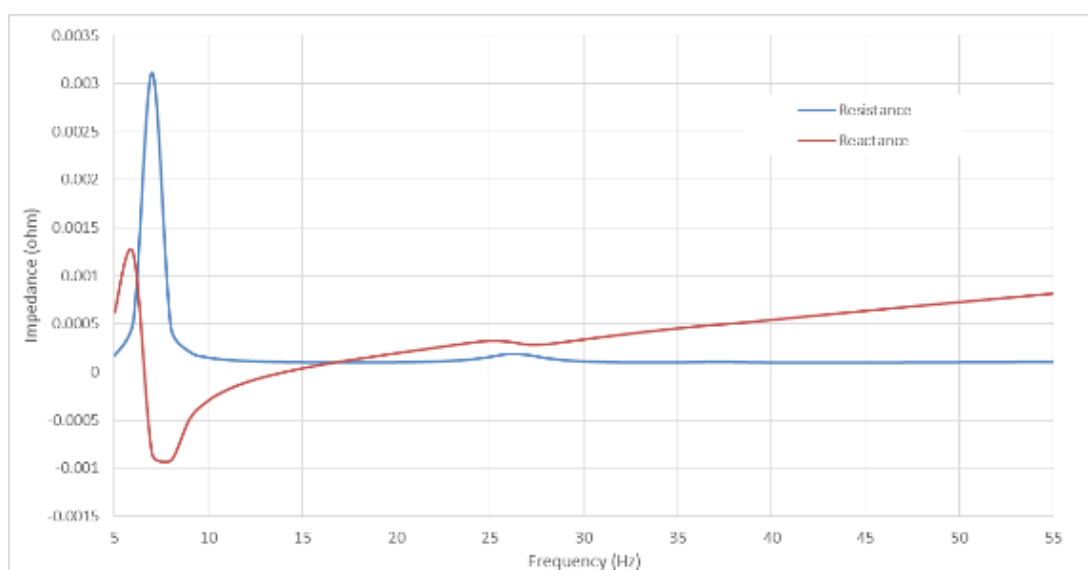

Figure 3.33: Frequency Scan Indicating Stable IGE/SSCI [Source: ERCOT]

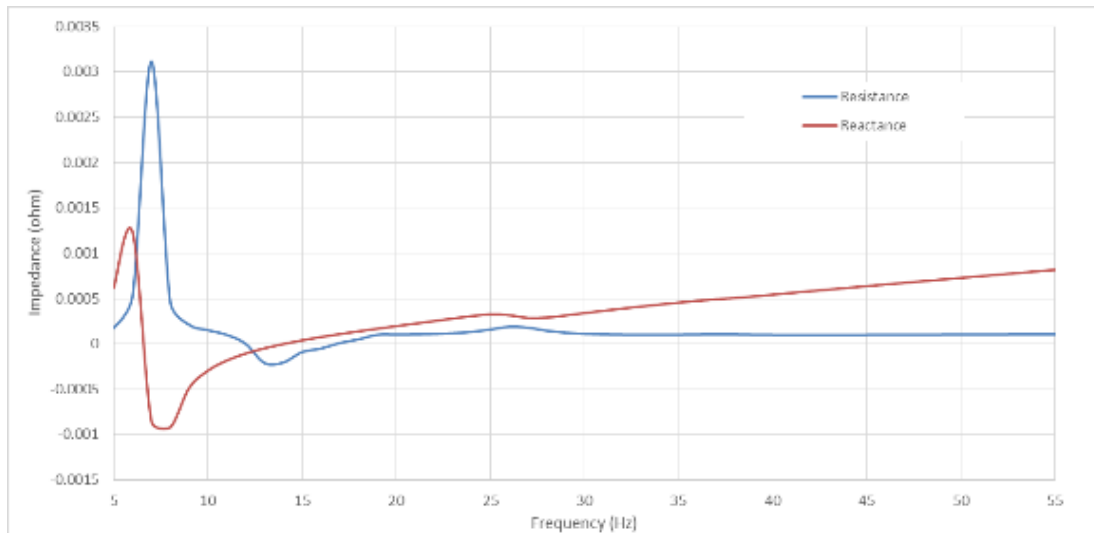

Figure 3.34: Frequency Scan Indicating Unstable IGE/SSCI [Source: ERCOT]

In eigenvalue analysis, the system is modeled by a set of linear differential equations written in the frequency domain (i.e., Laplace representation or state space representation). Mathematically calculating eigenvalues is a straightforward process and directly produces modes (resonant frequencies) and damping ratios (positive if stable; negative if unstable with the potential for SSR). The system must be linear in order to calculate eigenvalues directly, although indirect approximation techniques do exist.

EMT time domain analysis involves simulating the system in a program that fully calculates current/voltage waveforms using specialized electromagnetic transient models that are valid for subsynchronous frequencies. For synchronous generation, a full spring-mass model of the shaft is represented and for renewables the components of the electrical inverter controls are represented as well. Because time-domain analysis does not rely on linearization, it is sometimes used to confirm results of frequency scans or eigenvalue analysis. **Figure 3.35** shows a typical growing torque oscillation indicating a potential TI vulnerability.

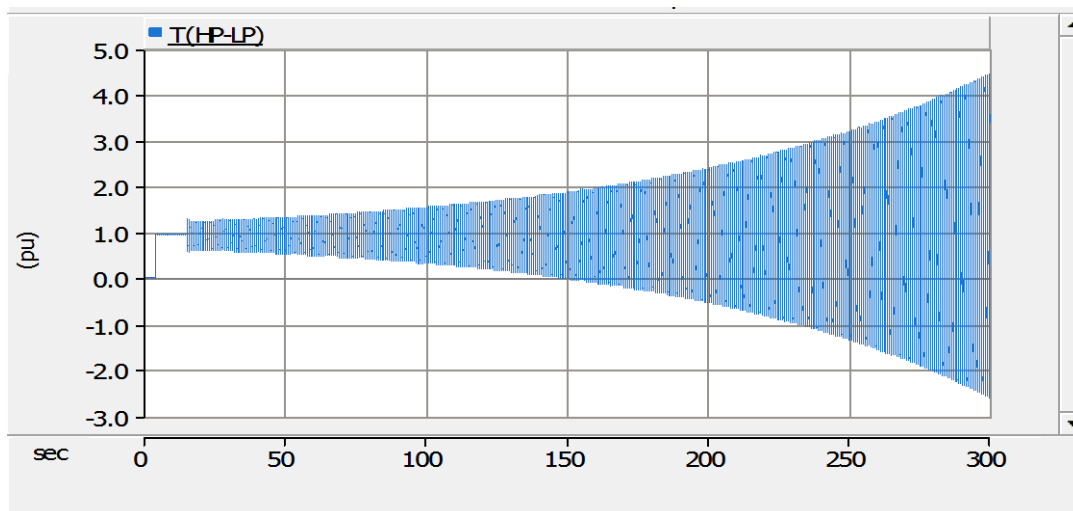

Figure 3.35: EMT Time-Domain Simulation Results (Torque on HP-LP shaft) Indicating Unstable TI

[Source: ERCOT]

To help offset the computational burden of using more detailed models in EMT time domain simulations, SSR studies typically use reduced system models and only include transmission elements in the vicinity of the series capacitor

and the generator under study. Because the studies are more suited for the planning horizon than the operations horizon, SSR studies may also consider multiple transmission outages and system operating conditions. SSR is often described as a “high impact, low likelihood event;” thus, study scenarios are chosen with careful thought.

The establishment of an IROL can be used to protect the generation from potential controls instability issues. These issues do not typically arise in high short circuit strength systems or when all lines are in service. However, unexpected outage conditions or other conditions with relatively lower short circuit strength may lead to these issues. Therefore, an IROL may be used to set a specific generator (or multiple generators) output or transfer across an interface to limit the controls instability from occurring.

Chapter 4: Uncontrolled Separation Assessment Techniques

Controlled separation and uncontrolled separation are phenomena that generally occur in the transient time frame.⁵¹ Analyzing controlled separation and differentiating it from uncontrolled separation involves a thorough understanding and modeling of the installed protection systems, RAS, and other control systems as designed. This section describes the principles and assessment techniques for controlled separation and uncontrolled separation in the context of Planning Assessments, OPAs, and RTAs.

Description of Controlled Separation

Controlled separation refers to the intended islanding of a portion of an electric system that includes generation or load. Intended islanding involves purposefully designed protection systems, RAS, or other control systems operating as designed to separate part of the BPS. Controlled separation is considered to be controlled because the points of separation are specifically designed to operate based on local detection or remote transfer trip signals. The separated systems have been studied to perform acceptably for the specified contingency events. Any unplanned or unexpected operation of a protection or control system is not considered intended. Controlled separation that results from those automatic control actions may help ensure the integrity of the rest of the system by disconnecting potentially weak or unstable portions of the system.

Controlled separation involves islanding generation or load; however, the island may or may not maintain stability throughout the separation depending on the design. Intentional, planned disconnection of load caused by RAS action to maintain stability following a credible contingency event is considered controlled separation. The tripped load will not remain energized, yet this is planned and designed ahead of time. On the other hand, larger controlled separation may intentionally form islands of large amounts of balanced⁵² generation and load that would otherwise result in instability for the given contingency event. See [Appendix C](#) for an example of a large controlled separation scheme and how it is differentiated from uncontrolled separation.

Contingencies that consequentially result in a small portion of generation and load to island and disconnect from the BPS are a separate and distinct issue from controlled (and uncontrolled) separation. Planned situations may arise where the topology condition and contingency could cause the formation of an island. In such scenarios, if the contingency were to occur, an island would be formed as a result of the contingency. These situations generally include a small load pocket caused by the contingency event. Contingency analysis tools are able to identify these conditions and provide information during outage studies, OPAs, and RTAs. While these conditions should be avoided to the best extent possible to minimize any loss of load, they should not be characterized as controlled (or uncontrolled) separation. The contingency event simply causes a consequential loss of load.

Description of Uncontrolled Separation

Uncontrolled separation refers to the unintended islanding of a portion of an electric system that includes generation or load. Unintended refers to the unplanned removal of a portion of the electric system due to operation of protection or control systems. Uncontrolled separation occurs when studies indicate that a contingency is expected to trigger relay action that causes the system to break apart into islands in an unintended (non-deliberate) manner. For example, the operation of transmission (or generation) protection systems caused by unexpected power swings across a key transmission circuit connecting two systems for a contingency in one of the subsystems would be considered uncontrolled separation since the operation of the relays was not intended for this contingency. The identification of actions from protection schemes, RAS, and other control systems that could lead to uncontrolled separation is not a trivial task. Demonstrating controlled separation requires knowledge of the conditions for which those systems actuate. Separation events are considered uncontrolled until otherwise proven by study to be

⁵¹ This is one of the main differentiations between cascading.

⁵² Controlled separation schemes may be accompanied by automatic generation or load tripping schemes or other automatic actions designed specifically to achieve generation/load equilibrium in the separated system(s) following the contingency event.

controlled through operation of protection systems, RASs, or other control systems intentionally used to separate portions of the system.

Figure 4.1 shows an example of a stability assessment for a sequence of actions leading to uncontrolled separation and system instability. The contingency causes intended operation of protection systems to clear the faulted element. A RAS is then triggered to trip generation and load to stabilize the system as is intended and expected for this contingency. Because the system is stressed beyond its stability-limited transfer capability (exceedance of the stability limit, which takes into consideration the RAS actions), voltages reach very low values in various parts of the system. Out-of-step scanning discussed previously for the assessment of rotor angle stability (OSSCAN) for transmission elements detects unintended tripping of elements due to the potential operation of impedance relays. The System separation that follows leads to the creation of two islands, both unstable as shown by the resulting overfrequency and undervoltage conditions after separation. In this example, operation of the protection schemes to clear the faulted element and the actions performed by the RAS are considered intentional; whereas, the tripping of transmission elements leading to the separation is unintended and not acceptable.

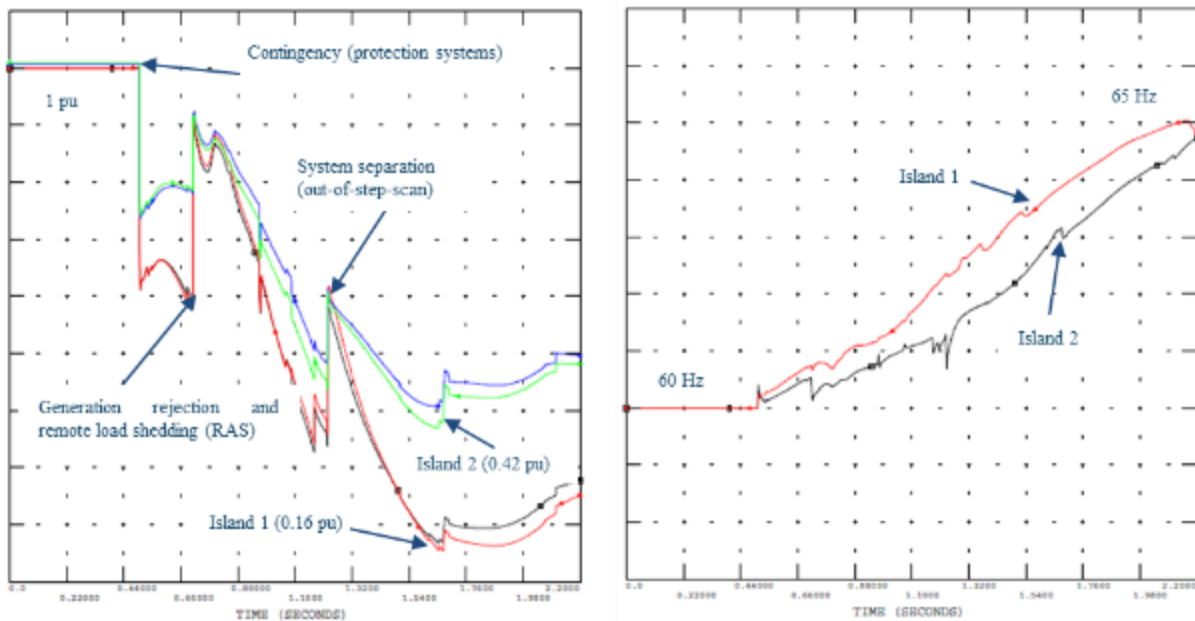

Figure 4.1: Sequence of Intended and Unintended Actions Leading to Uncontrolled Separation – Island Voltages and Frequencies

[Source: Hydro Quebec]

Overview of Controlled and Uncontrolled Separation Analysis

Uncontrolled separation is a challenging concept to study, particularly since it can be contributory or a result of instability or cascading, and is also difficult to simulate. **Figure 4.2** shows an overall flowchart for analyzing uncontrolled separation events and whether an IROL should be established. The contingency event under study is simulated and results obtained. Assume that some type of separation is identified in the simulation results. It then must be determined whether or not the separation was a controlled separation or an uncontrolled separation. The descriptions in the preceding sub-sections will help with this determination. If the separation event is deemed controlled separation based on intended protection or control system action specifically designed to detect and separate at distinct locations, this event would not constitute the need to establish an IROL. If the separation is considered uncontrolled separation, further analysis is needed to determine whether that uncontrolled separation resulted in system instability (see the sections on instability assessment techniques for more information). If so, this warrants establishment of an IROL. If not, then the amount of load loss resulting from the uncontrolled separation can be determined. The RC should have clear, explicit criteria for conditions where an IROL should be established for

uncontrolled separation. Conversely, controlled separation and how it is applied in studies should be well understood and documented by the RC.

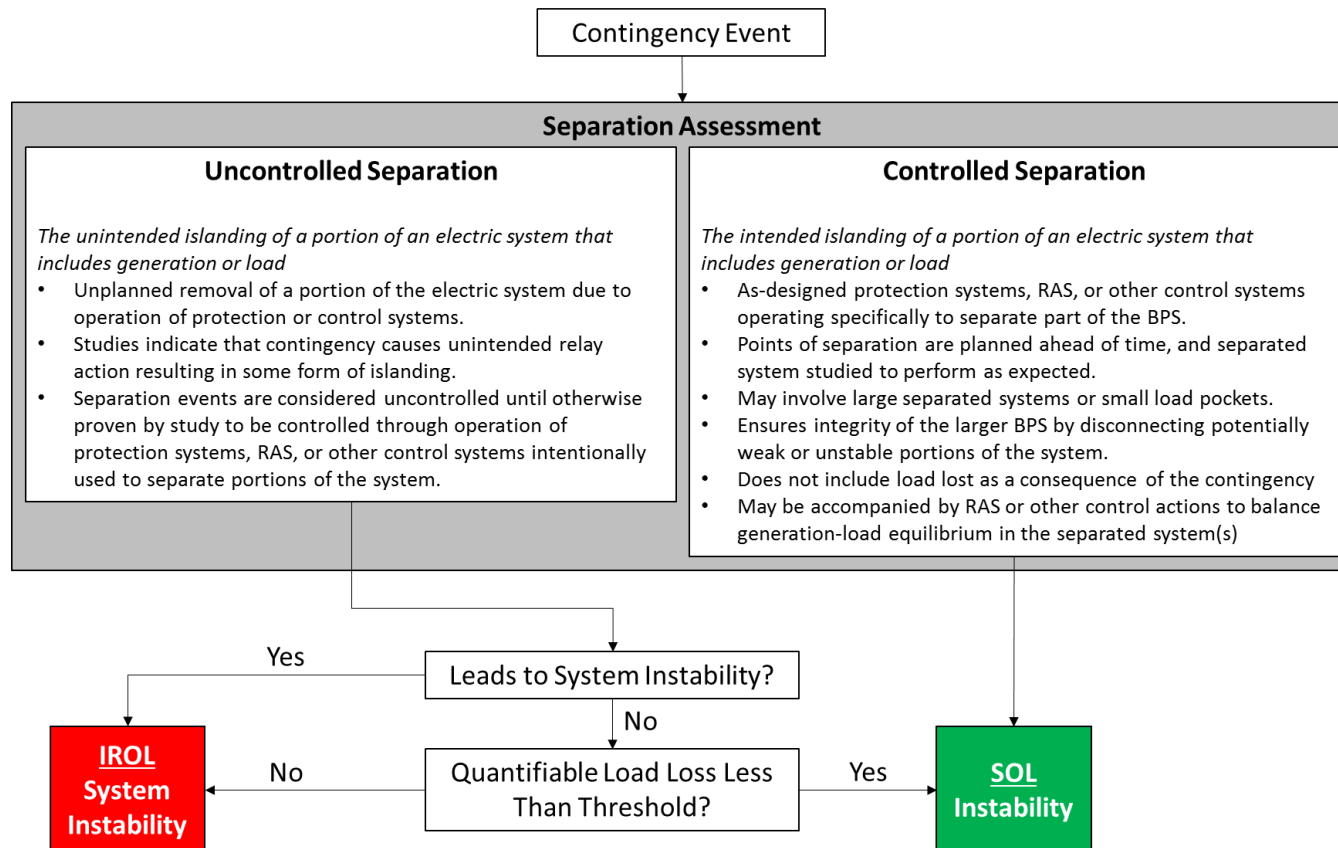

Figure 4.2: Overview of Controlled and Uncontrolled Separation Analysis

Example Comparison of Controlled and Uncontrolled Separation

The Florida-Southern Interface is an excellent example of the comparison between uncontrolled separation and controlled separation. Stability studies show that some extreme events, including the loss of a large generating facility (> 2500 MW) in Florida during high import conditions results in transient instability. The FRCC has a RAS that triggers a controlled separation between peninsular Florida and the rest of the Eastern Interconnection for these types of events. The separation points are at locations that can reliably detect out-of-step conditions and are also the boundaries between PC footprints.

Figure 4.3 and **Figure 4.5** show bus frequencies and voltage magnitudes at key locations when the RAS and individual out-of-step relays operate as designed to execute a controlled separation. Note that approximately 5,000 MW of load is tripped via UFLS for the controlled separation since greater than 2,500 MW of generation is lost in addition to 3,200 MW of power imports. UFLS operates at 59.6 Hz, 59.4 Hz, and 59.2 Hz with 0.1 second intentional delay in Florida. In a controlled separation, peninsular Florida separates from the Eastern Interconnection at pre-determined locations due to the RAS and four individual out-of-step relays. At each of the separation points there are auto-synch relays that will reclose the tie-lines once voltage and frequency conditions are acceptable, which is expected to occur after UFLS and within seconds of the separation.

If the RAS fails to operate, an uncontrolled separation occurs as shown in **Figure 4.4** and **Figure 4.6**. Two of the four out-of-step relays operate and then eight lines trip via their distance relays. Unlike the controlled separation scenario where peninsular Florida separates from the rest of the Eastern Interconnection at tie lines between different TOP/BA

areas, the uncontrolled separation points are within the neighboring TOP/BA areas with significant amounts of generation and load pulled into the disconnecting island. This presents unmanageable challenges to system operators, and the system is not designed to separate in this manner for these reasons.

The DISTR model is used on some lines in the simulation to model the actual distance relay settings, and on other lines only the generic OSCAN model is used. Uncontrolled separation occurs in about 3.7 seconds, instead of about 2.7 seconds for controlled separation. Transient instability conditions result in more severe bus voltages for the uncontrolled separation compared with the uncontrolled separation—GSU high side voltages of FRCC units briefly approach 40 percent of nominal (see [Figure 4.7](#)), and the voltage at a nuclear plant in a neighboring system falls below 90 percent for almost two seconds (see [Figure 4.8](#)). The dynamic simulation model does not include all protective relays and auxiliary systems that may trip the unit(s) due to depressed voltage; however, it is clear that the risk of plant tripping is significantly higher for the uncontrolled separation conditions.

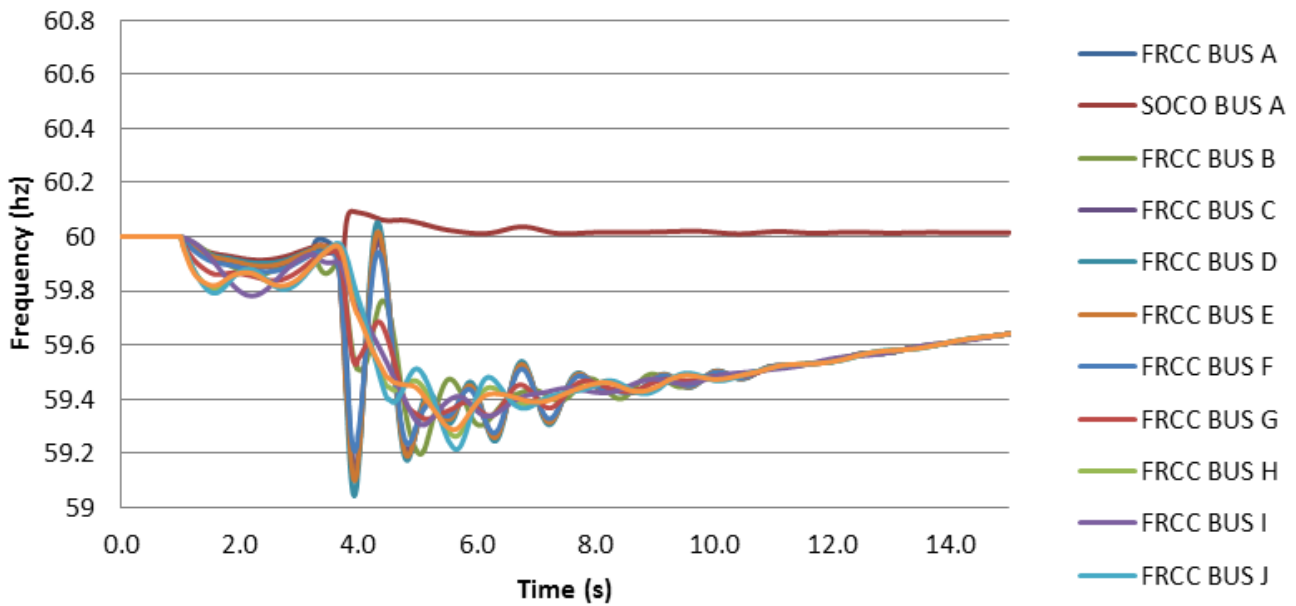

Figure 4.3: Bus Frequencies for Florida Controlled Separation
 [Source: Florida Power & Light]

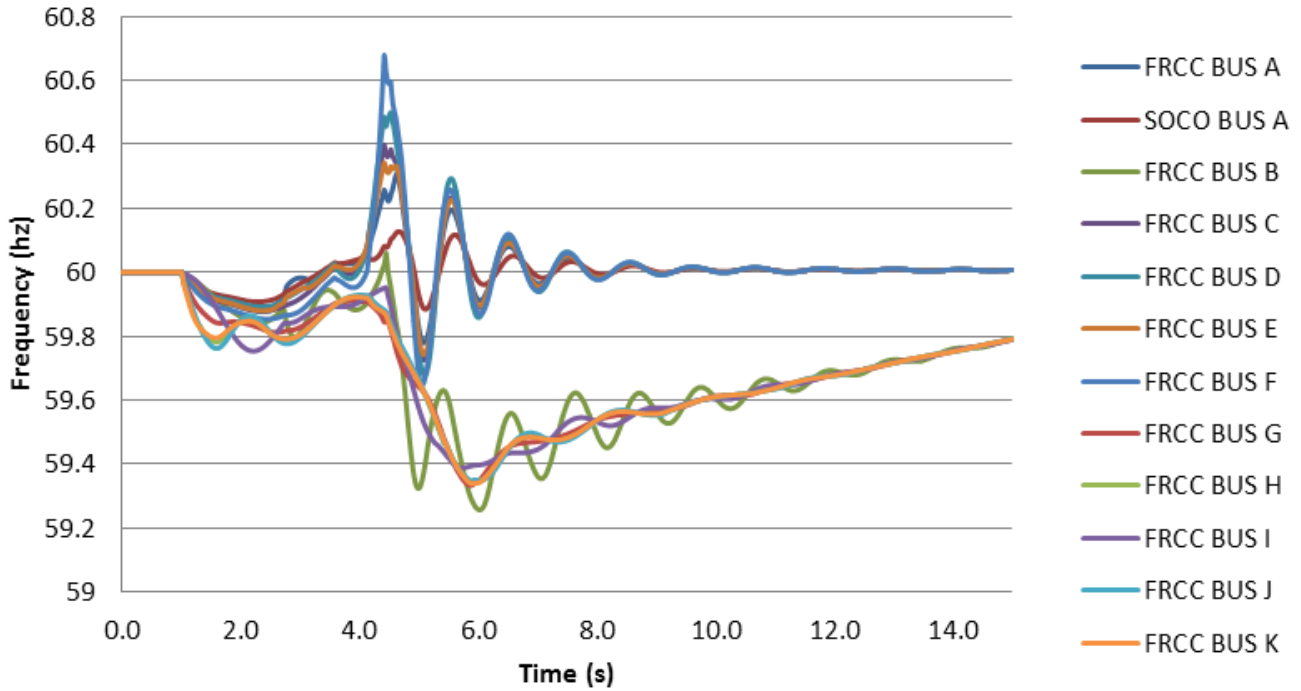

Figure 4.4: Bus Frequencies for Florida Uncontrolled Separation

[Source: Florida Power & Light]

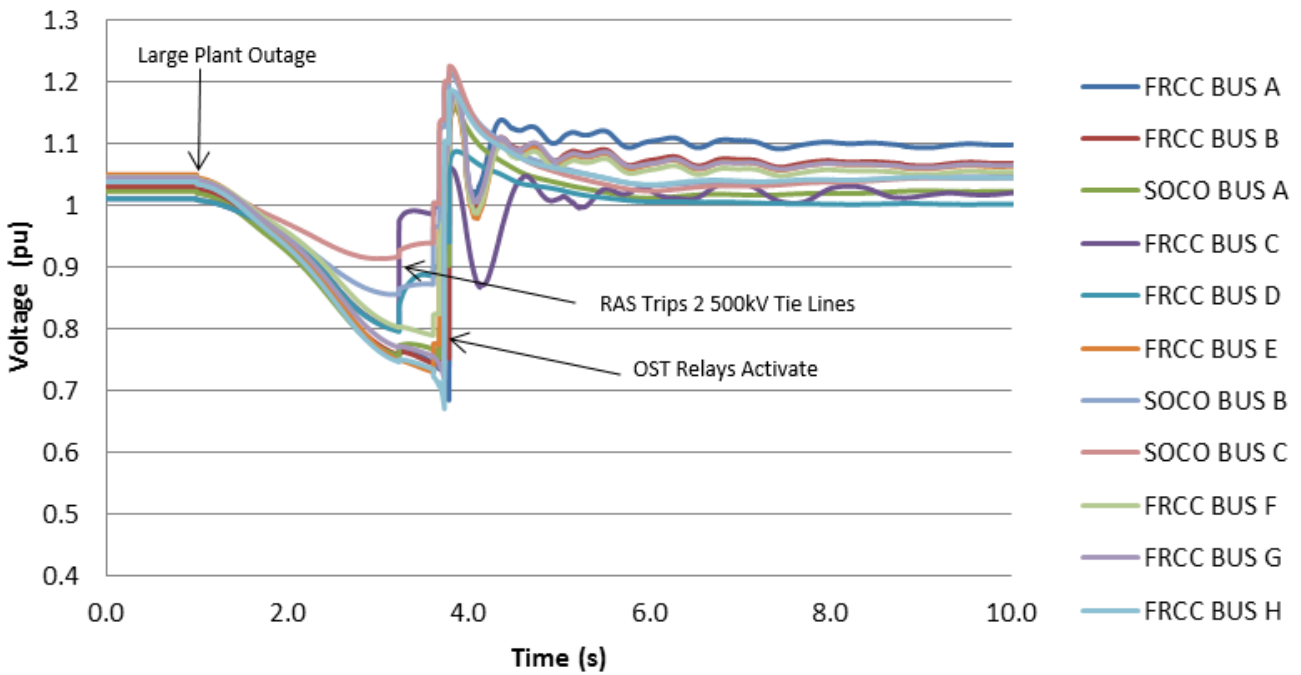

Figure 4.5: Bus Voltage Magnitudes for Florida Controlled Separation

[Source: Florida Power & Light]

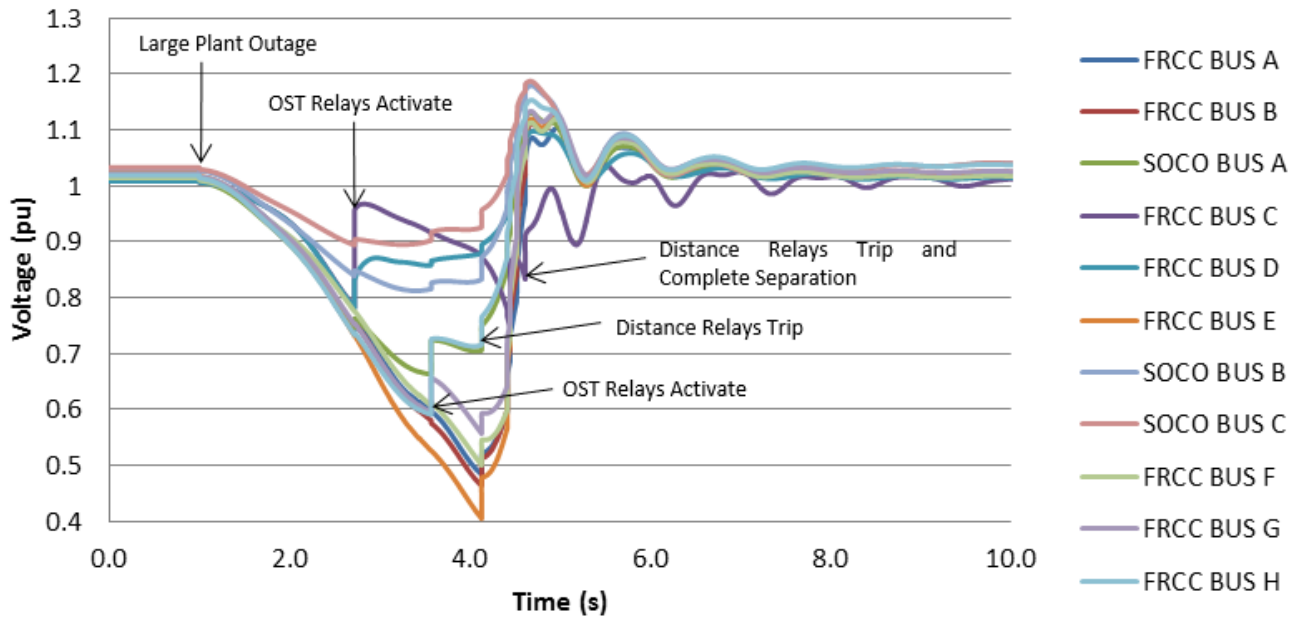

Figure 4.6: Bus Voltage Magnitudes for Florida Uncontrolled Separation

[Source: Florida Power & Light]

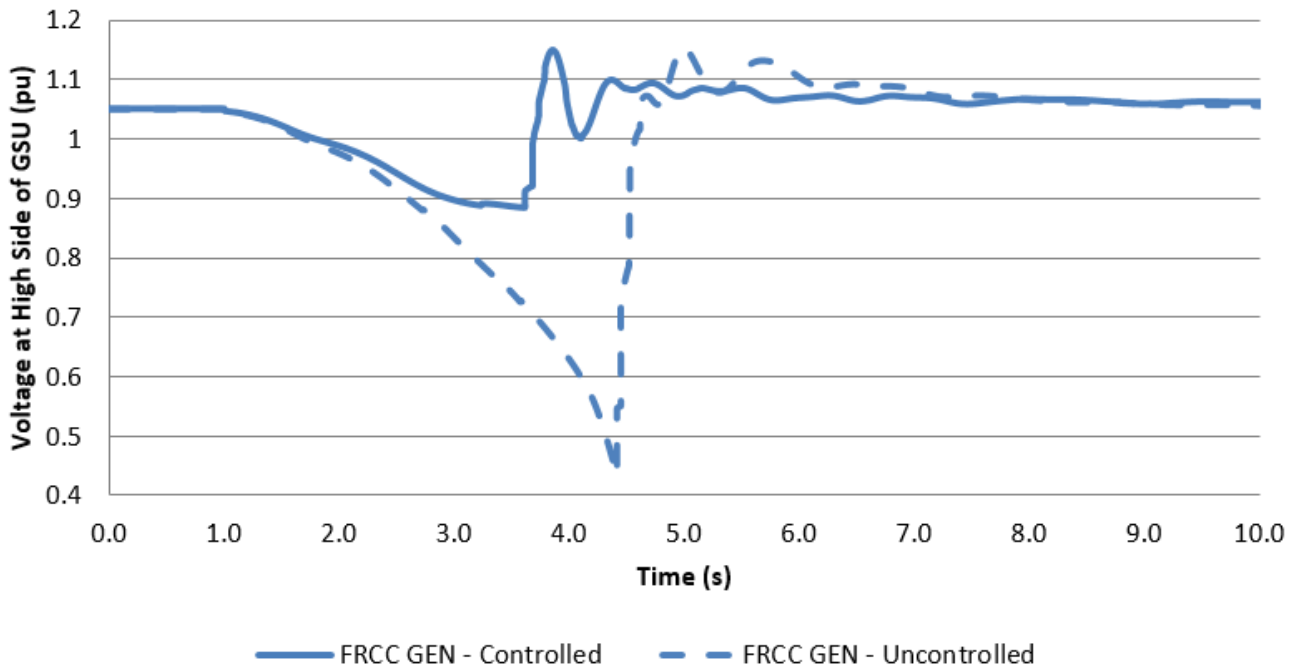

Figure 4.7: Impacts to Plants in Northern Florida for Separation Events

[Source: Florida Power & Light]

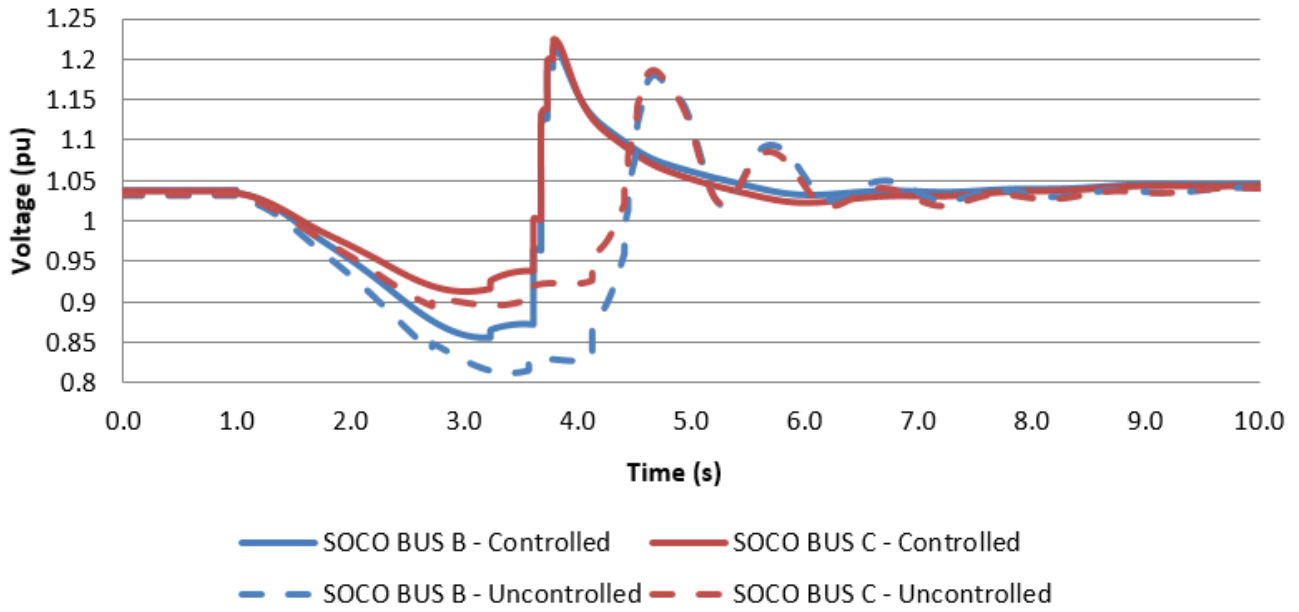

Figure 4.8: Impacts to Nuclear Plant in Neighboring System for Separation Events
 [Source: Florida Power & Light]

Chapter 5: Cascading Analysis Assessment Techniques

This chapter introduces the concepts of cascading, the assumptions and technical considerations that are used in developing a cascading analysis methodology, and then describes a process for cascading analysis techniques.

Proposed Definition and Description of Cascading

The MEITF proposes the following definition for cascading to describe the overall phenomenon:

Cascading: The uncontrolled successive loss of System Elements triggered by a Disturbance.

This definition addresses the true concept of cascading, referring to any uncontrolled⁵³ successive tripping of elements of the BPS. This new definition removes the concept of “widespread” from the definition. Cascading can occur on a system, which may or may not be widespread. The severity of cascading, and not how widespread it is, should be used to determine whether an IROL should be established to ensure reliability. As with stability, it is not the potential of the cascading event itself that determines if an IROL is needed, but the extent of the impact to the BPS that determines if an IROL is needed. For example, if the loss of one transmission circuit causes an overload and successive tripping of another transmission circuit, that is generally characterized as cascading. However, depending on the particular situation, that cascading event may or may not have an impact on the overall reliability of the BPS. This section describes the analysis of cascading and considerations that should be made during analysis of any potential cascading event.⁵⁴

Bounded vs. Unbounded Cascading

One concept that is critical to the determination of cascading and its impact on the BPS is whether or not an uncontrolled successive loss of system elements stops (“bounded”) or continues to some undefined operating state (“unbounded”). These two end states can be described as follows:

- **Bounded Cascading:** Cascading (uncontrolled successive loss of system elements triggered by a disturbance) that stops after some number of elements have been removed from the system is “bounded cascading.” Cascading stops when all elements are within pre-defined thresholds and no further successive tripping of elements will occur. Bounded cascading may occur in situations of higher impedance transmission circuits surrounded by (or connected to) a relatively strong network. The weaker elements with lower thermal capacity may overload and be successively tripped; however, after these elements are tripped, the stronger backbone system is able to accommodate the redistribution of power flows and conditions reach a new state with no further exceedance of facility ratings or system voltage limits. This also can occur around load or generation pockets where insufficient inlets or outlets to a load or generation pocket can lead to cascading within the pocket. Once the load or generation is dropped, the cascading stops because the load or generation is removed and a new balance is found.
- **Unbounded Cascading:** Cascading (uncontrolled successive loss of system elements triggered by a disturbance) that subsequently results in system instability⁵⁵ is considered “unbounded cascading.” The cascading does not reach a new steady-state and the system enters into a truly dynamic, uncontrolled

⁵³ A circuit tripping due to thermal overload (e.g., transmission line sag into right-of-way) on primary or backup protection (e.g., protection to clear a fault) is considered “uncontrolled” and should be considered part of cascading. System protection or RAS that are designed and intended to trip an element following a contingency to prevent overloading, maintain stability, or prevent further uncontrolled actions would be designed and implemented accordingly, and therefore would be considered controlled actions. These are built into the contingency definitions, studied ahead of time, and are a component of any cascading analysis (although not deemed cascading if they occur).

⁵⁴ Another useful industry reference is the NATF Reference Document developed for CIP-014-2 related to Requirement R1 and the development of a risk assessment for defining critical substations. Available: [HERE](#).

⁵⁵ Unbounded cascading inherently results in an outcome of system instability. Otherwise, the instability is quantifiable and further cascading can be analyzed. The unbounded cascading results in an operating condition that is cannot be further studied because it results in an instability that is not quantifiable (i.e., system instability).

condition. A simplified approach to defining unbounded cascading is when the number of system elements successively tripped during the cascading exceeds a limit that is defined in the SOL Methodology. In this situation, the entity is not willing to take the risk of that number of system elements being removed from the system and considers that an unacceptable state. This also helps simplify the simulation techniques to a reasonable number of combinations to study.

The determination of the extent to which cascading is acceptable and whether it requires the establishment of an IROL should be clearly defined in the SOL Methodology and should follow the following concepts:

- If the cascading is unbounded, this is not acceptable and warrants the establishment of an IROL.
- If the cascading is bounded, then the amount of generation and load lost should be quantified, and as follows:
 - If the amount of load loss exceeds the allowable limit established in the SOL Methodology, this is not acceptable and warrants the establishment of an IROL.
 - If the amount of load loss does not exceed the allowable limit established in the SOL Methodology, this is acceptable and does not warrant the establishment of an IROL.

Cascading Fundamentals and Cascading Trees

The analysis of cascading is generally performed using steady-state powerflow tools and contingency analysis to study any successive overloading and potential tripping of system elements. More advanced cascading analysis techniques may also include transient stability simulations to identify potential instabilities that may occur in the dynamics time frame that would not be captured in steady-state. Dynamics may also be considered if a cascading condition results in an unsolved powerflow to verify the instability and identify the element(s) that experienced this as part of the cascading event.

Tripping of transmission elements due to excessive loading of the line is normally due to the physical attributes of the equipment or the relay settings of the relays protecting the equipment. Exceeding a facility's thermal rating can cause failure of that facility. For example, transformers excessively loaded past their thermal ratings may cause a mechanical or dielectric failure, which would cause the transformer to fault and trip out of service. Loading a conductor past its thermal rating can cause excessive sag of the transmission line, and if the line sags past clearances, it may fault and trip out of service. Excessive loading of equipment past its facility rating could also cause misoperation of the associated protective relays. For example, when coupled with depressed voltages, high current on a facility may appear as a fault to an impedance relay.

When transmission elements trip out of service, the power that was flowing on the element must be picked up by the remaining transmission system. The majority of power will be transferred on the electrically close transmission elements. This phenomenon is what creates the potential for cascading. A transmission element that is excessively loaded can trip and distribute that loading to the neighboring transmission elements. The remaining elements could then be excessively loaded and trip, distributing that element's loading to other neighboring transmission elements. This sequence of cascading can continue on to subsequent elements leading to bounded or unbounded cascading.

Cascading can occur in a series configuration (**Figure 5.1**), parallel configuration (**Figure 5.2**), or, most likely, some combination of both. Cascading that propagate in a series configuration tend to occur when the transmission system has high Line Outage Distribution Factors (LODFs) with each other. Because of this, when a line is outaged, the majority of power is transferred to fewer lines, causing those lines to load up more. Cascading can also propagate in a parallel configuration where a single line outage will cause multiple lines to load up and possibly trip. This can cause branches of cascading events that can then propagate further either in a parallel or series configuration. As a potential cascading event is studied, the larger the number of elements that trip and the more branches that are created increases the complexity of the study when trying to determine if it is bounded or unbounded and the extent of the impact.

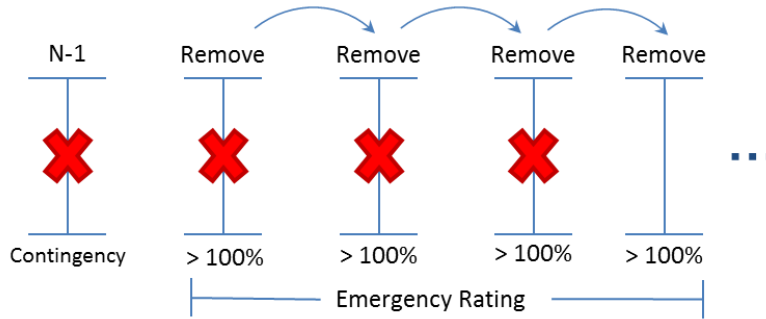

Figure 5.1: Description of Series Cascading
[Source: TVA]

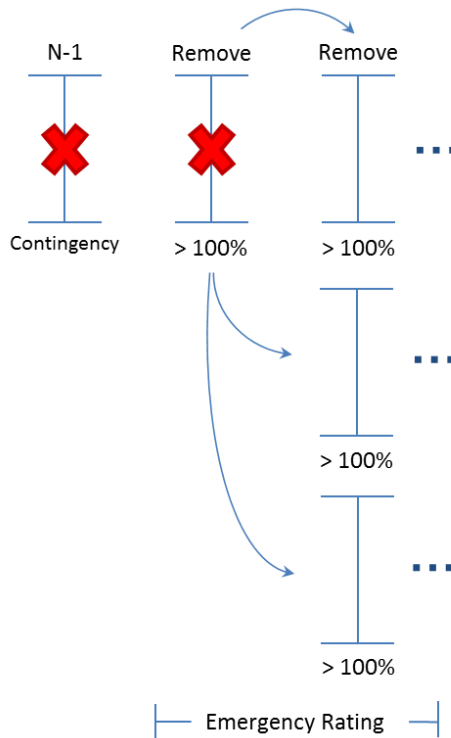

Figure 5.2: Description of Parallel and Series Cascading
[Source: TVA]

The start of a cascading analysis normally begins when a planning or operations planning study shows a potential for a transmission element to be near the overload threshold. This triggers the need for further evaluation to determine if an IROL should be established in order to prevent the system from operating at or past that point. The analysis of cascading should consist of removing elements from service that meet or exceed the overload threshold to determine the extent of the cascading (bounded or unbounded) and the significance of the impact of the cascading. As each element is removed from service, the model is resolved and the power from the contingent element is redistributed on the system. Next, any other elements that exceed the overload threshold are removed from service and the process continues until there are no more elements that exceed the overload threshold. If the cascading propagates far enough, it can be considered unbounded where the powerflow solution diverges.

Figure 5.3 shows an illustration of the cascading analysis sequences. An $N-k$ ⁵⁶ event is used as the initiating disturbance. Three overloads are identified, each with a distinct path. Removing the first results in another overload with two more options. One of those options leads to a diverged powerflow solution (unbounded cascading) while the other option leads to other overloads and/or bounded cascading where a powerflow solution is obtained with no overloading and acceptable voltage levels. The second overload following the first cascading step leads directly to a diverged powerflow solution. Lastly, the third overload leads to additional bounded cascading scenarios.

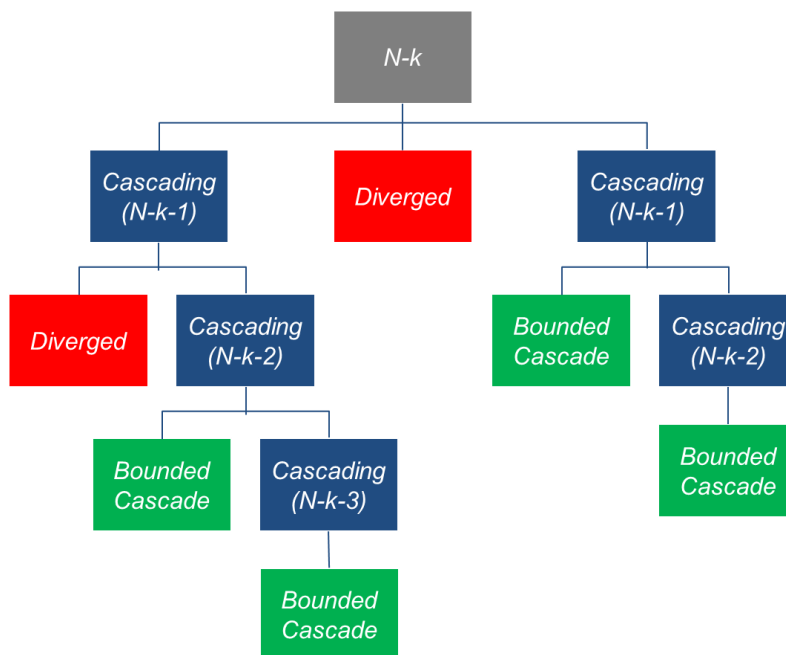

Figure 5.3: Simple Cascading Tree Example

In reality, cascading trees⁵⁷ are much more complex. **Figure 5.4** shows an actual tree from cascading analysis simulations. The initiating event (green node) leads to many different paths of cascading, involving many different elements and operating conditions. The red dots show unbounded cascading (diverged powerflow solution) conditions while blue dots show bounded cascading conditions. Note that some cascading paths lead to unique operating points while other paths converge on a similar operating point. The sequence of outages taken may or may not lead to a unique solution, and the probability of reaching that point may be different.

⁵⁶ $N-k$ simply denotes k elements removed from service from the initiating contingency. This is conventionally $N-1$ or select $N-2$ contingencies for the determination of SOLs. In other cases, for example CIP-014-2 analysis, k may be a larger number for the loss of an entire substation bus(es).

⁵⁷ E. Bernabeu, K. Thomas, Y. Chen, "Cascading Trees", CIGRE Science & Technology, October 2017.

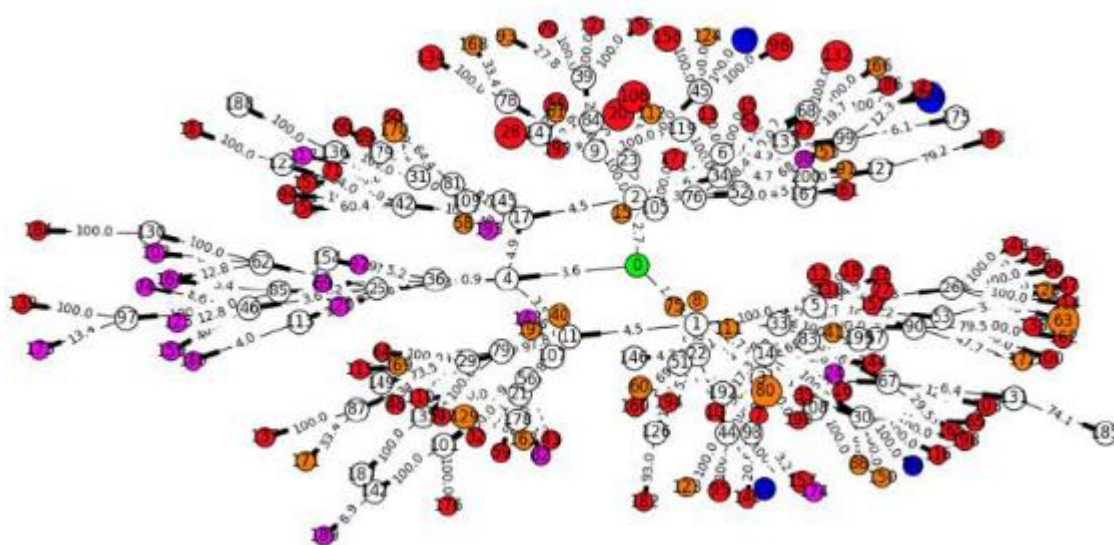

Figure 5.4: Actual Cascading Tree Example

[Source: PJM, Dominion]

To describe the process of cascading analysis, it is important to first discuss the various assumptions that go into the cascading analysis. These are discussed in the subsequent sub-sections and include the following:

- Low voltage generator and load tripping
- Defining cascading overload thresholds
- Inclusion of facility ratings methodologies and protection system assumptions
- Accounting for numerical issues that cause powerflow solution divergence

Low Voltage Tripping as Part of Cascading Analysis

Bus voltages should be monitored during the cascading analysis process, particularly at generator terminal buses and load buses. Low bus voltage that results in tripping of generation or load could exacerbate the cascading through additional overloading, cause the cascading to be deemed unacceptable due to the size of generation or load lost, or mitigate further cascading. The following considerations should be made:

- Generators that experience a low bus voltage have a higher propensity to trip off-line (e.g., auxiliary bus loads) and a generator tripping threshold should be determined. For example, one could assume that generators with steady-state bus voltage less than 0.9 pu would trip—this would align with the requirements of PRC-024-2 generator voltage ride-through requirements. Similarly, one could use slightly lower thresholds, such as 0.8 pu to 0.85 pu, as reasonable generation trip thresholds.

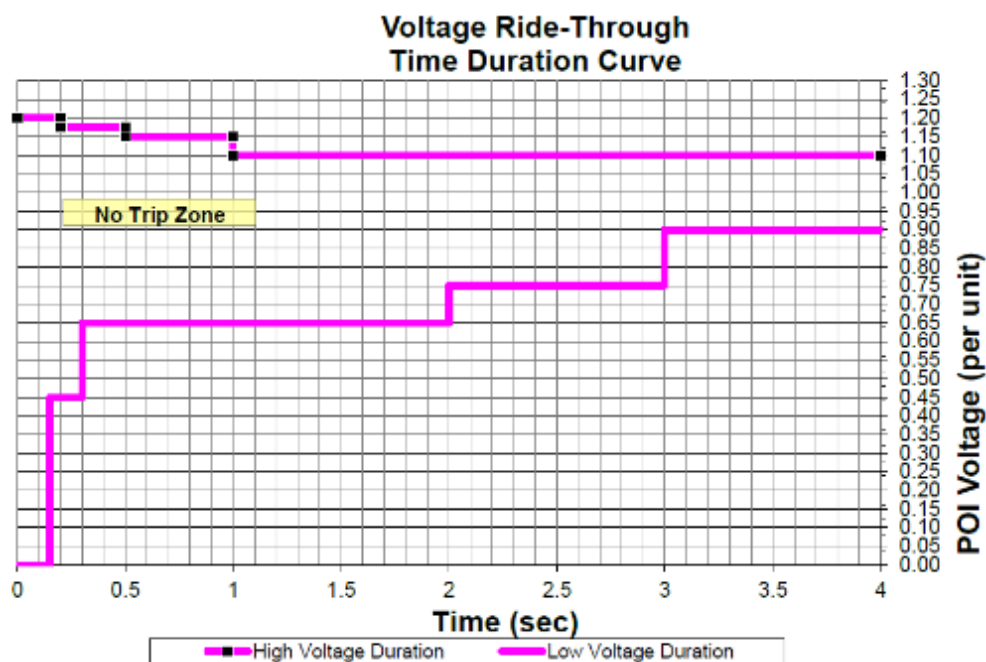

Figure 5.5: PRC-024-2 Voltage Ride-Through Time Duration Curve

- Loads are expected to begin dropping out for a number of reasons (e.g., contactor dropout, process-based controls, power electronic controls). A low voltage threshold for load tripping should be selected based on engineering judgment and an understanding of the load composition. Below this threshold, all or a portion of the load at the affected buses should be tripped as part of the cascading. For example, one could assume that half the load trips at 50 percent voltage and all the load has tripped at 40 percent voltage.⁵⁸

Note that many software tools include a parameter (e.g., PQBRAK in PSS/e) that controls the load characteristic under low voltage conditions. The constant power characteristic holds the load power constant until bus voltage falls below the specified threshold. A current-voltage characteristic (shown in [Figure 5.6](#)) is used to determine the load current for the given voltage. This helps obtain a powerflow solution under severe voltage conditions. However, if this is not set appropriately for cascading analysis, it can skew results. The amount of load reduction should be tracked for each iteration in the cascading analysis, and the value for PQBRAK should be set in coordination with the load tripping fractions (i.e., this parameter could be used to model the load reduction if set and tracked accordingly).

⁵⁸ In reality, this is likely a continuum. However, the simulation tools do not generally have an effective means of voltage-based load tripping. Therefore, engineering judgment and simplifying assumptions are often made.

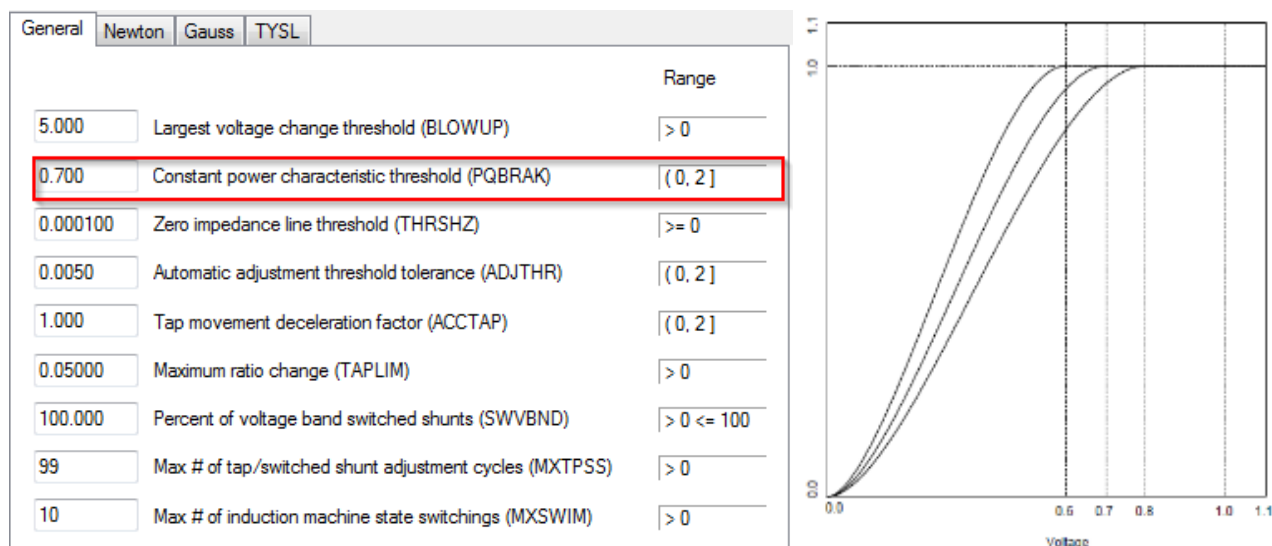

Figure 5.6: Constant Power Load Characteristic Solution Option and Characteristic

[Source: Siemens PTI]

If it is assumed that the load remains connected through the low voltage condition, this is often a conservative assumption. On the other hand, if it is assumed that some load trips, this is often less conservative (although more realistic). In either case, technical justification should be provided for the thresholds used. If the operating state obtained following the powerflow solution is stable (solved powerflow solution) yet the voltages are unacceptably low in a local or wide-area footprint, they may also be considered unacceptable cascading and an IROL established. Rather than perform the detailed analysis to identify tripping of load and generation, the utility may acknowledge that these are assumptions and that the very low voltages across multiple buses is unacceptable from a reliability standpoint and an IROL is established to mitigate this occurrence.

Defining an Overload Threshold for Cascading Analysis

Each element of the BPS has a likelihood of failure and tripping. While the likelihood of this occurring during normal operation is very low, that probability increases as the loading of that element reaches and exceeds its facility rating, particularly its highest Emergency Rating. Cascading analysis studies the successive loss of system elements, and there should be a strong technical basis for the thresholds used to instigate a successive tripping of elements in the studies of cascading and whether that cascading has a sufficiently large impact to establish an IROL. This technical basis should take into account, at a minimum, the following considerations:

- Facility rating—conductor ratings, equipment failure, etc.
- Generator tripping
- Relay loadability

The following sub-sections provide technical basis and recommendations for developing overload thresholds for cascading analysis.

Protection System Considerations

Relay loadability and load encroachment are critical components to cascading outages and should be considered when determining thresholds for cascading analysis. PRC-023-4 (or its successor) sets forth requirements to ensure coordination between relay loadability and relay operation such that transmission elements will not be tripped for

heavy loading conditions and only tripped for fault conditions.⁵⁹ PRC-023-4 (or its successor) provides a list of criteria that can be used to ensure the protective relay does not have a loadability issue. Some key criterion included in PRC-023-4 Requirement R1 include the following:

- Set transmission line relays so they do not operate at or below 150 percent of the highest seasonal facility rating of a circuit for the available loading duration nearest four hours (expressed in amperes).
- Set transmission line relays so they do not operate at or below 115 percent of the highest seasonal 15-minute facility rating of a circuit (expressed in amperes).
- Set transformer fault protection relays and transmission line relays on transmission lines terminated only with a transformer so that the relays do not operate at or below the greater of the following:
 - 150 percent of the applicable maximum transformer nameplate rating (expressed in amperes), including the forced cooled ratings corresponding to all installed supplemental cooling equipment.
 - 115 percent of the highest operator established emergency transformer rating.

From Requirement R1, it is clear that transmission line relays should not trip the element for loading below 115 percent of the seasonal 15-minute facility rating or below 150 percent of the 4-hour rating, and transformer protection should not trip for loading below 150 percent of nameplate rating or 115 percent of highest emergency rating. This ensures that transmission protection will not trip the line (without a fault), providing sufficient time for operator action. The time required to take these actions should be taken into account to determine reasonable percent of facility rating to use for the cascading analysis.

The criteria for thermal overload tripping during cascading analysis simulations should consider the thermal overload magnitude and duration specified in PRC-023-4 (or equivalent). Any transmission circuit is unlikely to trip on line relay operation unless it experiences a thermal overload of at least 115 percent of the 15-minutes emergency rating, or 150 percent of the 4-hour emergency rating, or any equivalent rating (e.g., 125 percent of the 30-minute emergency rating), based on the requirements outlined in the standard.

Facility Ratings and Operator Action

The facility rating for each facility is based on the most limiting component of that facility (e.g., line conductor, wave trap). The conductor rating has a time aspect associated with it that should be carefully taken into consideration in developing a technical basis for a specified cascading threshold. The chosen overload threshold should reflect the expected operating plans and time frame in which operators will have sufficient time to take action. Cascading normally occurs when the time between successive tripping is less than the time it takes for an operator to mitigate the loading on the facilities and bring the system back to a secure state.

To illustrate this concept, consider [Table 5.1](#), which shows actual data for a number of conductor types (columns in the table) for long term emergency (LTE), short term emergency (STE), and drastic action limit (DAL) ratings under expected summer conditions. Each column represents a different conductor type for each of the two sets of conditions (all cases assume ambient temperature of 40°C and pre-contingency conductor temperature of 85°C). For the left half of the table, the first column shows post-contingency ampere loading that results in a conductor operating temperature of 120°C in two to four hours. For example, if a line has a pre-contingency operating temperature of 85°C and then loads to 1270 A post-contingency, it will take two to four hours to reach 120°C (LTE rating). The second row shows post-contingency ampere loading that will result in a conductor operating temperature of 140°C after 15 minutes (STE rating). The third row shows post-contingency ampere loading that will result in a

⁵⁹ Note that PRC-023-4 applies to transmission lines operated at 200 kV and above (except GSUs directly connected to BES generators), transmission lines operated at 100 kV to 200 kV selected by the PC, transmission lines operated below 100 kV that are part of the BES and selected by the PC, transformers with low voltage terminals connected at 200 kV and above, transformers with low voltage terminals connected at 100 kV to 200 kV selected by the PC, and transformers with low voltage terminals connected below 100 kV that are part of the BES and selected by the PC.

conductor operating temperature of 140°C in five minutes (DAL rating). The right half of the table is similar to the left except that it assumes a line with less clearance (100°C instead of 120°C for the LTE and 120°C instead of 140°C for the STE and DAL ratings). The upper portion of the table shows the LTE, STE, and DAL ampere ratings under these conditions. The middle portion of the table relates the LTE (two to four hour) and STE (15 minute) ratings to the DAL rating (five minute) in terms of percentage. The lower portion of the table shows examples of overload threshold that could be applied for cascading analysis.

A blanket statement of some percentage value of the “highest emergency rating” is insufficient technical basis to determine the overload threshold used for cascading analysis. The protection, line sag, and equipment damage aspects should all be accounted for in determining appropriate cascading thresholds. The time aspects of these concerns should be accounted for when establishing this threshold.⁶⁰ Typically, the DAL (five minute) rating is assumed to be too severe for the operator to manage these conditions and either load shedding will occur or the facility will trip due to sag or failure. Similarly, the STE rating of 15 minutes is still relatively quick for an operator to assess whether cascading will actually occur and to be able to maneuver the system back to a point of security. Often, some percentage of the STE rating (15 minute or 20 minute) is used as a threshold for which it is assumed the element has some reasonable likelihood of tripping as part of a cascading event.

Table 5.1: Line Conductor Ratings vs. Time								
RATING*	Pre-load 2/4 hr 120°C				Pre-load 2/4 hr 100°C			
	15 and 5 min 140°C				15 and 5 min 120°C			
ACSR Size (Stranding)	795 (45/7)	954 (45/7)	1272 (45/7)	1590 (45/7)	795 (45/7)	954 (45/7)	1272 (45/7)	1590 (45/7)
LTE: 2 to 4 hour rating	1,270	1,429	1,718	1,988	1,096	1,231	1,476	1,704
STE: 15 minute rating	1,574	1,812	2,268	2,719	1,386	1,590	1,976	2,354
DAL: 5 minute rating	2,061	2,426	3,124	3,824	1,755	2,057	2,632	32,05
DAL as % of LTE	162%	170%	182%	192%	160%	167%	178%	188%
DAL as % of STE	131%	134%	138%	141%	127%	129%	133%	136%
STE as % of LTE	124%	127%	132%	137%	126%	129%	134%	138%
Examples:								
140% of LTE	1,778	2,001	2,405	2,783	1,534	1,723	2,066	2,386
125% of STE	1,968	2,265	2,835	3,399	1,733	1,988	2,470	2,943
115% of STE	1,810	2,084	2,608	3,127	1,594	1,829	2,272	2,707
100% of STE	1,574	1,812	2,268	2,719	1,386	1,590	1,976	2,354

*Ambient temperature: 40°C summer peak, conductor pre-load temp of 85°C

The red values in **Table 5.1** are intended as an example. Assume that a utility is using 125 percent of STE as their cascading threshold value. In this case, for these actual conductor ratings, 125 percent of STE is approaching the DAL (5-minute) rating and should be taken into consideration when establishing the threshold value. This is an optimistic value and it should be assumed that the operator has insufficient time to react. Similarly, assume a utility is using 140 percent of LTE as their threshold. For these conductors, 140 percent of LTE exceeds the STE rating, falling somewhere between the STE and DAL ratings. This means the operator would have somewhere between 5 to 15 minutes to react, which may be relatively unlikely.

⁶⁰ The protection standards focus on near-instantaneous protective relaying. The other noted aspects (e.g., line sag, equipment damage) may have longer duration failure modes. Line sag clearance should be accounted for, from a cascading analysis perspective, to ensure that public safety is not compromised.

The third portion of examples show ampere ratings when applying different cascading threshold values (e.g., 140 percent of LTE, 125 percent of STE, 115 percent of STE, and 110 percent of STE). Notice how the threshold values, for the same set of conductors and ambient conditions, can be significantly different based on the threshold values selected. This can have a substantial impact on the results obtained from the cascading tests. While 100 percent of STE may be on the conservative side for these examples, it is more than reasonable to assume that any overload above 100 percent of the elements highest emergency rating (e.g., STE) could result in tripping and that the operator does not have sufficient time to take action to address the overload. Conversely, it is fairly optimistic to assume that the operator could mitigate overloads up near 125 percent of STE (assuming 15 minute rating) within a suitable amount of time to mitigate cascading.

Key Takeaway

Thermal overload thresholds for cascading analysis should have a technical basis for the value used. This threshold should be based on the overload level with respect to time that overload can be sustained. This involves analysis of conductor ratings, engineering judgment, and expected operator action. Conservative thresholds would use 100 percent of the highest emergency rating while more optimistic thresholds may use a threshold based on operator time in the range of five to 10 minutes (either percentage of 4- or 8-hour rating or 15-minute rating, depending on utility facility ratings practices.)

Other Limiting Elements for Facility Rating

There are a number of other components that may be the most limiting rating in the determination of the facility rating for a BPS element. These components could have a detailed time-overload relationship that would need to be considered in such detail. One may assume that exceedance of those limits will result in failure of the component and tripping of the BPS element. Examples include wave traps, faulty splices, poorly hung conductor, and unmaintained structures. Even after the RC receives the facility ratings from its TOPs, the RC may not have a clear understanding of the most limiting component and its rating of the TOPs' BPS elements.

Figure 5.7 and **Figure 5.8** show the ratio of five minute rating to four hour rating and 15 minute rating, respectively, for circuits in an RC footprint where short term emergency ratings have been developed. **Figure 5.7** shows a gradual drop off towards a 1:1 ratio between the five minute and four hour ratings. At that point, that may be due to two primary factors: no five minute rating was provided to the RC, or the most limiting element is not time-dependent and treated the same as the four hour rating. **Figure 5.8** shows an even more significant drop off, where the majority of lines have a five minute rating that is equal to the 15 minute rating. The RC should consider the consistency of the facility ratings in their system and determine a reasonable value, in conjunction with the time frames associated with their operating plans, for an overload threshold for cascading analysis.

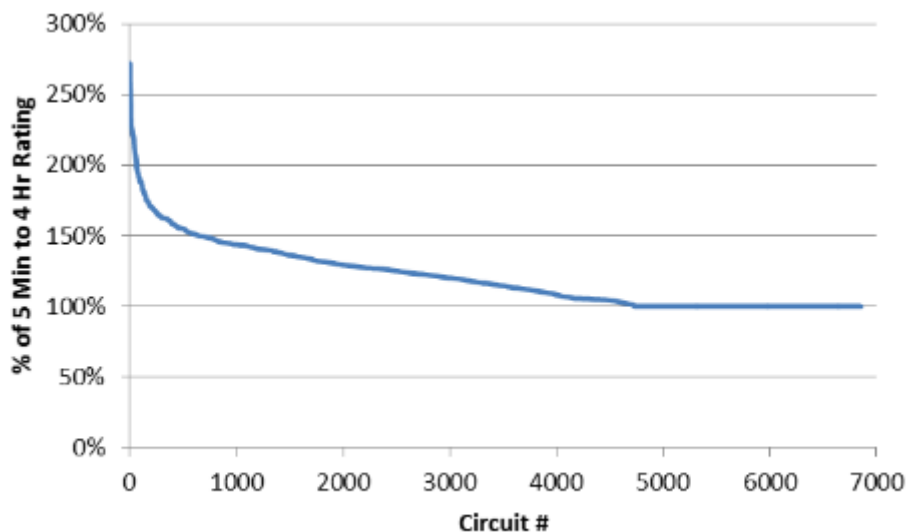
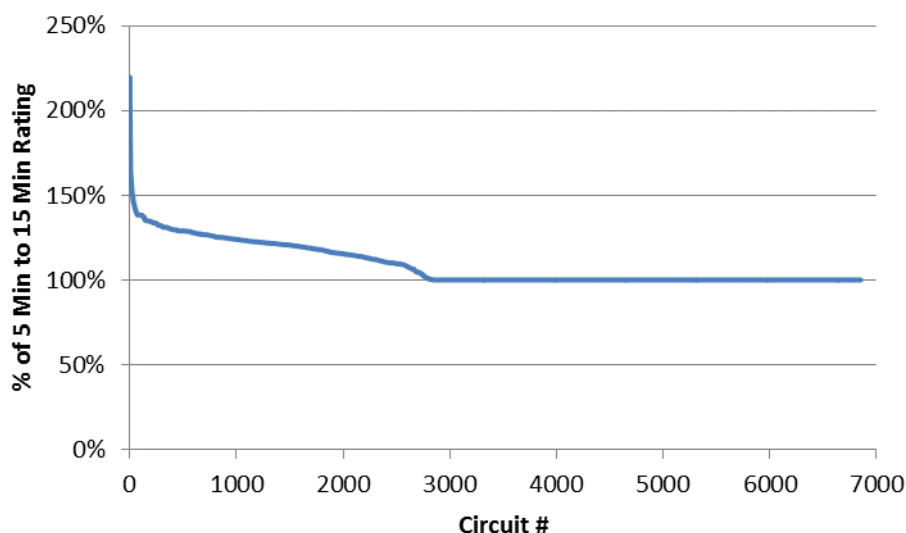

Figure 5.7: Circuit Five Minute Facility Rating as Percentage of Four Hour Rating**Figure 5.8: Circuit 5 Minute Facility Rating as Percentage of 15 Minute Rating**

Divergent Powerflow and “Soft Outage” Considerations

During the course of cascading analysis, and even contingency analysis, one must consider how they are drawing conclusions from the simulation results being provided. Engineering judgment should be used to determine if additional analysis or considerations need to be taken. One aspect of this additional analysis is the occurrence of a divergent powerflow. While this is commonly considered an unacceptable occurrence for contingency analysis purposes (especially in the operating time frame, time and tool permitting), the engineer should ensure that the divergent powerflow solution is actually due to an instability or unachievable operating state as opposed to numerical issues in the software tool. It is common to run into numerical software issues when performing cascading analysis.

A divergent powerflow solution does not necessarily mean that the cascading is unbounded or that instability has occurred. In fact, any analysis methodology that solely uses a divergent powerflow as criteria for characterizing unacceptable levels of cascading should be very careful in determining that the divergent case is truly an unacceptable operating state.

The methodology should consider the power flow solution options used in the study. These may include the following:

- Load ramping at low voltage: does the power flow solution ramp load down below some predefined voltage (e.g., 0.5 pu)?
- Does the solution convert constant power load to constant impedance load below some predefined threshold (e.g., 0.7 pu)?

These options are often configured to some level as default in the software programs and should be addressed to ensure consistency across and RC footprint. This can drastically change the frequency and occurrence of unsolved powerflow cases.

When a system element is removed from service in the powerflow, the solution is moving directly from one steady-state operating state to a new steady-state operating state without consideration for how the system will reach this new state dynamically. Large changes in system state variables may cause the powerflow solution to diverge under

severely stressed conditions. To account for this, a “soft outage” approach has been proposed,⁶¹ referring to how system elements are removed from the case to transition between these operating states. The following steps can be taken to soften the outage numerically while still reaching the same post-contingency operating state. At each step in the “soft outage” approach the powerflow is solved to reach an intermediary operating point while the system is eased into the new operating point.

- **Transmission Element Impedance Increase:** The impedance (predominantly the reactance) of a transmission element, such as a line or transformer, can be increased in steps to gradually reduce the power transfer across the element (see [Figure 5.9](#)). At some threshold (e.g., 0–20 percent of initial flow) the element can be removed from service and the redistribution of flow and change in voltages will be less severe than the initial outage of the element.

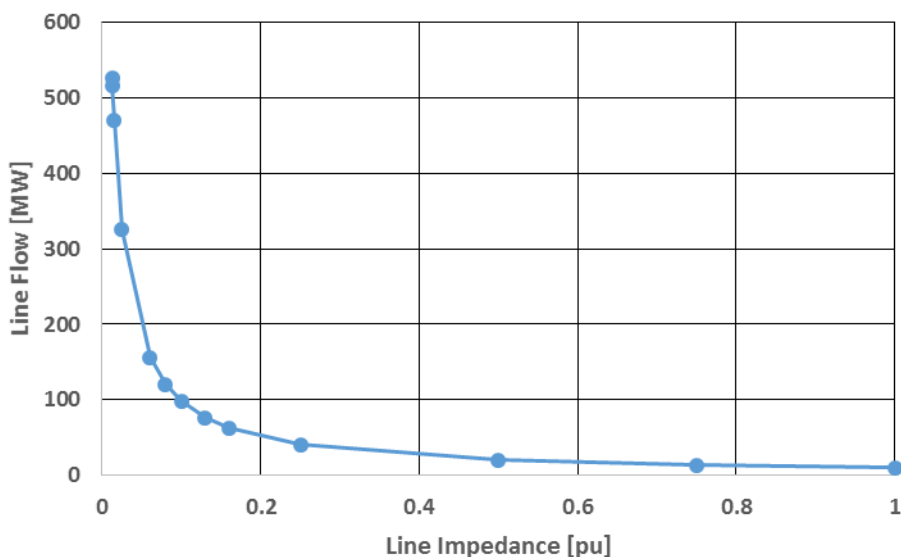

Figure 5.9: Line Flow vs. Line Impedance

- **Generator Output or DC Power Order Reduction:** The same concept applies to gradually reducing power output from a generator or power transfer across an HVDC element. Once the output or transfer is low enough, the user can open the element and solve the powerflow.
- **Reactive device output reduction steps:** Delivery of reactive power to maintain voltage is critical in cascading analysis, particularly as the outages weaken the system and drive higher need for reactive power (higher impedance). Reactive element (e.g., SVCs, STATCOMs, shunt reactive elements) outputs can also be ramped down gradually to ease the powerflow solution.

These steps are useful in situations where a diverged powerflow is reached. The previous successfully solved powerflow solution (with the element in service) is used as the starting point and that element is gradually removed from the case through a sequence of powerflow solutions. Load levels are not changed based on collapsing voltage at these soft outage steps, only outaged grid elements are adjusted to ease the tripping effects in the load flow solution. If a new operating state is reached, the cascading analysis can continue as normal. If a diverged powerflow solution is still the outcome, it can be concluded that this is likely an actual system instability condition or unacceptable operating state.

⁶¹ “Cascading Trees: A Methodology to Integrate Resiliency in Transmission Planning,” CIGRE Grid of the Future Symposium, 2017.

“Cascading Trees: Probabilistic Risk Assessment Methodology.” Electric Grid Resiliency Modeling Industry Summit, Industry workshop facilitated by Dominion Energy and PJM, Sept 22, 2015.

This analysis is very beneficial in identifying the root cause of the instability due the element being removed from service. For example, line flows and system voltage can be monitored at each successive powerflow solution. Generally a select set of bus voltages or overloads are the cause of the instability. This type of information is not available in the initial solution where a diverged powerflow is the outcome—the gradual ramping and intermediary solutions provide this information. However, this method does include some shortcomings (along with the standard approach described herein as well), such as lack of protection system modeling, no dynamic simulation, etc. However, it may not be practical to consider all these aspects in the cascading analysis.

Typical Cascading Analysis Process

It may not be practical to simulate all possible combinations of cascading; however, it is important to understand that the cascading phenomenon consists of a tree of potential solutions and that the assumptions used in cascading analysis drastically simplify the analysis down to a certain set of cascading paths in the tree. While all possible combinations of cascading should ideally be studied, two methods are often considered when selecting the next element to remove from service as part of the cascading:

- Trip the highest overloaded element
- Trip all overloaded elements above some threshold

Simultaneous tripping of overloaded elements is very rare. Even if a couple seconds apart from each other, this is not considered simultaneous. Therefore, tripping all overloaded elements in a single iteration of the cascading analysis should be avoided. On the other hand, experience has shown that tripping the most overloaded element may not always lead to the worst outcome or the highest likelihood sequence. To identify each of those cases would require a full analysis of the cascading tree. Regardless, tripping the element with the highest overload is a reasonable assumption for sequential cascading analysis.

Key Takeaway:

Tripping the element with the highest thermal overload is a reasonable assumption for cascading analysis and recommended unless more extensive cascading trees or sensitivities are explored. After each successive tripping, a credible powerflow solution should be obtained and bus voltages and thermal overloads monitored.

Tripping of successive elements to simulate cascading is performed in an iterative process. **Figure 5.10** provides a flowchart that should, at a minimum, be used for cascading analysis. The following steps describe the process:

1. The initiating contingency is taken, similar to contingency analysis.
2. Solve the powerflow.
 - a. If a direct powerflow solution cannot be attained, then the “soft outage” techniques are used to attempt to achieve a solution. If a solution is still not feasible,⁶² and model and data accuracy have been validated, this is considered system instability and an IROL should be established.
 - b. If a solution is attained, continue to the cascading analysis.
3. Identify if any elements are overloaded.
 - a. If no elements are overloaded, go to Step 7.
 - b. If elements are overloaded, identify them and rank their overload severity.
4. Disconnect or trip the highest overloaded element in the case.

⁶² During the soft outage, if a clearly quantifiable collapsing load pocket is identifiable, one may analyze whether protective relaying (e.g., line distance protection or bus UVLS, if applicable) may trip the load or element. If this can be proven, cascading analysis can be continued. Otherwise, a viable solution is not obtained and it is deemed system instability since there is no way to determine how the collapsing elements will propagate into the system. Any reduction in load due to low voltage should not occur during the “soft outage” steps.

5. Track the cumulative amount of load tripped consequentially from the cascading. This may get compared against a load loss threshold or considered with other factors in the determination of an IROL.
6. Solve the powerflow.
 - a. If a direct powerflow solution cannot be attained, then the “soft outage” techniques are used to attempt to achieve a solution. If a solution is still not feasible, and model and data accuracy have been validated, this is considered unbounded cascading and an IROL should be established.
 - b. If a solution is attained, continue in the cascading analysis.
7. Check generator and bus voltage magnitudes for any above or below acceptable limits where they are expected to trip.
 - a. If no generator or load bus voltage magnitudes are above or below the thresholds, return to analyzing the overloaded elements and solving the powerflow solution.
 - b. At this point, if no overloaded elements are identified, this is considered bounded cascading and the cascading is expected to stop.
 - c. If high or low bus voltages exist, trip the generator or load⁶³ at that bus.
8. Solve the powerflow.
 - a. If a direct powerflow solution cannot be attained, then the “soft outage” techniques are used to attempt to achieve a solution. If a solution is still not feasible, this is considered unbounded cascading and an IROL should be established.
 - b. If a solution is attained, continue in the cascading analysis.
9. Track the cumulative amount of load tripped (along with the load consequentially tripped after the overloaded element removal). Again, this may get compared against a load loss threshold or considered with other factors in the determination of an IROL.
 - a. If the cumulative amount of load lost exceeds any identified threshold, this should be considered unacceptable cascading performance and an IROL should be established.
 - b. If not, return to the successive analysis of checking overloaded elements and continue the cascading analysis.

Entities may consider slight modifications to this process that strengthen the analysis. This could include analyzing powerflow solution mismatches as well as incorporating stability simulations as part of the cascading analysis. These techniques were omitted in the description simply because they complicate a description of the overall process and may not be required for the minimum set of cascading analysis steps.

⁶³ While generation is likely to trip, one may consider a method for tripping a fraction of the load at a given bus rather than the entire load at that bus. As the fractional value of load is tripped, this may help alleviate the voltage issue. Hence, the justification of tripping only a fraction of the load. The load diversity and different voltages seen along the distribution feeder also help support this method.

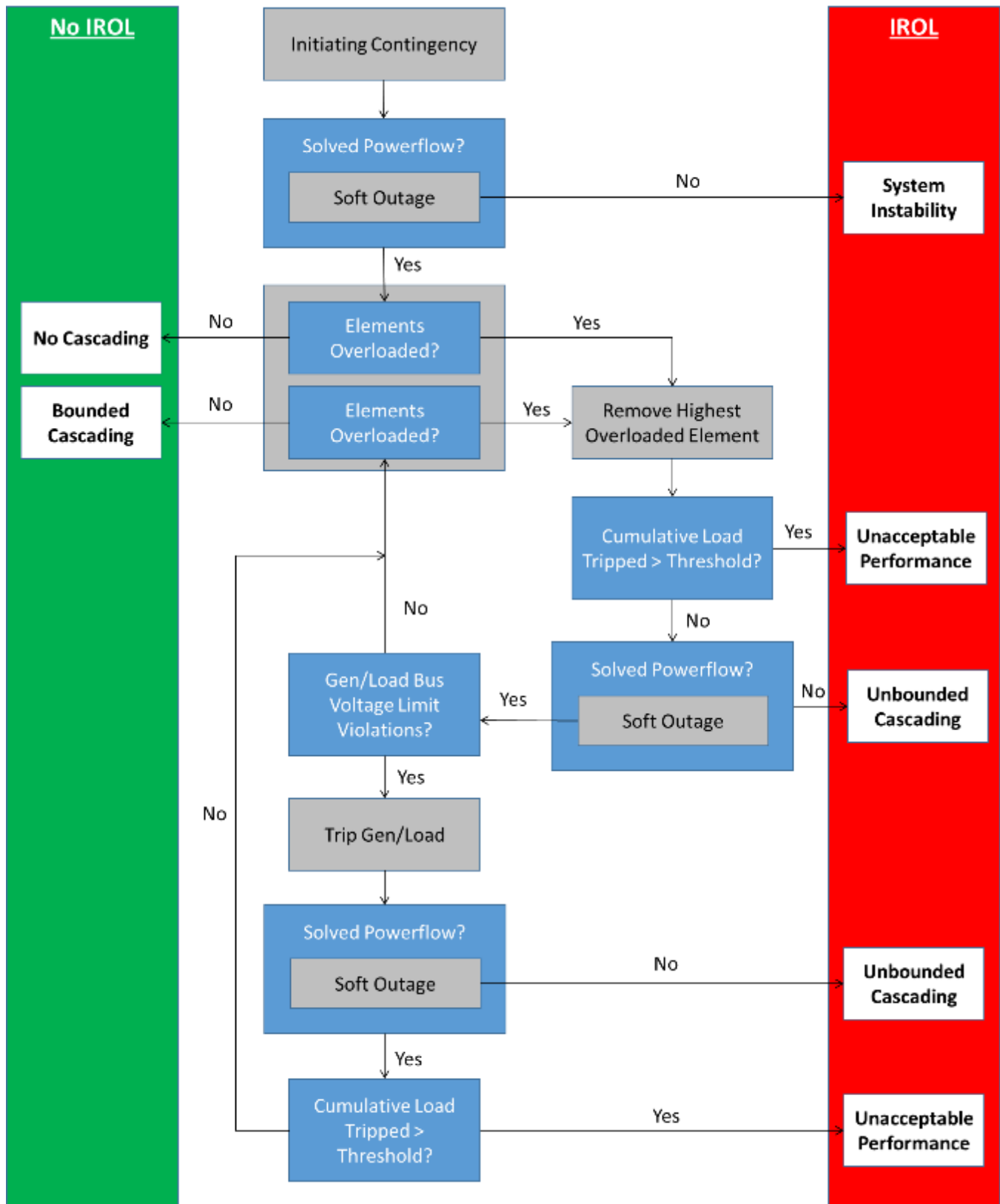

Figure 5.10: Cascading Analysis Flowchart

Probabilistic or Risk-Informed Cascading Analysis

Cascading events inherently involve some level of probability that the sequence of events will occur. Some cascading events may have a very low probability of occurring (e.g., multiple elements tripping sequentially due to exceeding their highest emergency rating by one percent) while other cascading events may have a very high probability of occurring (e.g., multiple elements tripping sequentially due to exceeding their highest emergency rating by 50 percent). Particularly under high system stress or outage conditions, the probability of cascading is likely higher since the redistribution of flows has a higher impact on adjacent facility loadings.

Some entities have considered using probabilistic or risk-informed methods for cascading analysis. This type of analysis uses the probability of tripping, potential equipment loss of life, and amount of load loss at each sequence of the cascading path. **Figure 5.11** shows an example of a probability-based tripping curve. Each condition is assigned a probability of tripping based on engineering judgment and known facts of the equipment being considered. For example, the probability of tripping may be based on the overloading level of a transmission line, the overloading level of a transformer, the encroachment of distance protection, the magnitude of low terminal bus voltage at a generator, etc.

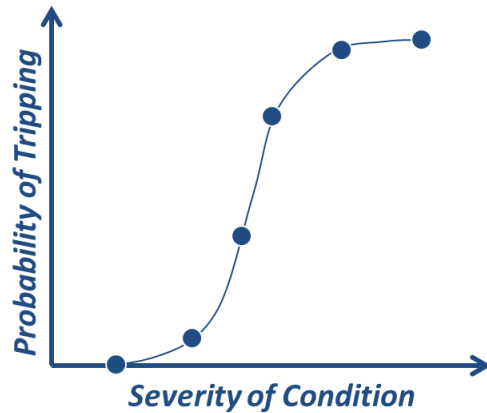

Figure 5.11: Concept of Probabilistic Tripping

Each step in the cascading path is then assigned a probability, and the conditional probability of this path occurring is calculated to determine the overall likelihood of the cascading to occur. The probability for each cascading path can be calculated as follows:

$$P(c) = P(c_1|N-1) \cap P(c_2|c_1) \cap \dots \cap P(c_n|c_{n-1})$$

Where the probability of the cascading event $P(c)$ is the conditional probability of cascading, c_1 is the first cascading event, $N-1$ is the initiating disturbance,⁶⁴ $P(c_1|c_2)$ is the probability of cascading event two given cascading event one, and $P(c_n|c_{n-k})$ is the probability of cascading event n given cascading event $n-k$. Whether the cascading is bounded or unbounded, the probability of its occurrence is taken into consideration to determine whether the probability meets a defined risk threshold. That risk threshold should have a technical basis (e.g., one percent risk of cascading vs. 0.1 percent risk of cascading), and any unbounded cascading should be protected regardless of its probability unless thorough analysis and technical justification can prove why that risk is being assumed.

These probabilistic concepts for cascading analysis are continuing to evolve and improve, and the tools associated with the analysis of cascading are also improving. As these tools and techniques continue to evolve, it is likely that the study practices will also improve. Currently the ability to perform probabilistic assessments in the operations horizon is limited; however, this may be more doable in the longer term planning horizon.

⁶⁴ The initiating disturbance does not necessarily have to be an N-1 contingency. It could be a credible N-2, or it could even be the loss of an entire substation for CIP-014-2 security assessment.

Appendix A: FERC Orders and Directives

This section provides relevant paragraphs from FERC Orders that discuss IROLs. Note that the Commission speaks through its orders (and not the absence thereof). Each order should be read in its entirety to obtain the appropriate context of a particular order. The paragraphs describing IROLs are provided here only for reference.

FERC Order No. 693 (Issued March 16, 2007)⁶⁵

519. “The Commission reaffirms its belief that Reliable Operation of the [BPS] can only be achieved by coordinated efforts of all operating entities, such as [RCs], [TOPs] and [BAs] in operating their respective systems and performing their respective functions in accordance with their responsibilities and authorities. Most operating actions taken by [TOPs] and [BAs] in real-time would only affect their own areas and equipment and have no adverse impacts on the [IROLs], and therefore they have unilateral authority to act. However some operating actions that would have impacts beyond their own areas must involve the [RC] who has the wide-area views and the necessary operating tools, including monitoring facilities and real-time analytic tools with wide-area representation to enable the [RC] to fulfill its responsibility... the Commission believes that actions that have an impact beyond an area will, in general, vary based on the conditions at the time of the action.”

F225. “The NERC glossary states that A reliability coordinator is the “entity that is the highest level of authority who is responsible for the reliable operation of the bulk electric system, has the wide-area view of the bulk electric system, and has the operating tools, processes and procedures, including the authority to prevent or mitigate emergency operating situations in both next-day analysis and real-time operations. The reliability coordinator has the purview that is broad enough to enable the calculation of IROLs, which may be based on the operating parameters of transmission systems beyond any transmission operator’s vision.” NERC Glossary at 15.”

524. “...which requires each [RC] to ensure that all [TOPs], [BAs] and others operate to prevent the likelihood that a disturbance, action, or non-action in its reliability coordinator area will result in a SOL and IROL violation in another area of the Interconnection. In order for the [RC] to carry out its function under IRO-005-1, it must have information from the [TOPs] and [BAs]. However, IRO-005-1 does not require [TOPs] and [BAs] to provide the [RC] with the information it would need to prevent the likelihood that an action from these two entities will result in a SOL or IROL violation in another area of the Interconnection. The Commission’s directive ensures that the [RC] has such information. Therefore, we do not believe that COM-002-2 is duplicative of IRO-005-1.”

554. “...load shedding is the option of last resort and there may be other options available to alleviate IROL violations within 30 minutes.”

555. “With regard to the wording of the proposed modification stating that load shedding should be capable of being implemented “as soon as possible and in much less than 30 minutes,” the Commission agrees...that this language may be unclear and unduly subjective. In the NOPR, we stated that the reference to 30 minutes could suggest that anything up to that limit was acceptable and proposed the modification to emphasize our concern that implementation was expected much sooner than in 30 minutes...Accordingly, we direct the ERO to develop a modification through the Reliability Standards development process clarifying that when the load reduction plan of Requirement R2 involves load shedding, such load shedding be capable of being implemented as soon as possible when required to mitigate an IROL violation but in no case in more than 30 minutes.”

577. “...As explained in the NOPR and in the Blackout Report, actions undertaken under the TLR procedure are not fast and predictable enough for use in situations in which an operating security limit is close to being, or actually is being, violated...the Commission agrees...that the TLR procedure may be appropriate and effective for use in

⁶⁵ Mandatory Reliability Standards for Bulk-Power System, 18 CFR Part 40, Docket No. RM06-16-000, Order No. 693 (Issued March 16, 2007). Available: <https://www.ferc.gov/whats-new/comm-meet/2007/031507/E-13.pdf>

managing potential IROL violations. Accordingly, the Commission will maintain its direction that the ERO modify the Reliability Standard to ensure that the TLR procedure is not used to mitigate actual IROL violations.”

578. “...we are precluding use of TLR procedures at times of actual IROL violations, but are not otherwise specifying permissible responses.”

710. “In response to EEI’s concerns that removing the existing 200 kV threshold could expose the Bulk-Power System to a new set of risks, we clarify that we are not immediately modifying this Reliability Standard. Instead, it will go into effect as written and the ERO will revise it through the Reliability Standards development process, with the expectation that the applicability of this Reliability Standard will expand to include additional facilities that impact reliability that currently are not covered by this Reliability Standard. A modification that reduces the applicability of this Reliability Standard would not meet the Commission’s directives. In response to SoCal Edison’s argument that the Reliability Standard already addresses the Commission’s concerns, the Commission agrees that while there appears to be a mechanism for inclusion of additional lines, none have been included. This lack of inclusion is in spite of the evidence that some lower voltage lines can have significant impacts on the [BPS], including IROLs and SOLs.”

757. “EEI and TVA raise concerns that this modification promotes commercial use of the grid rather than ensuring Reliable Operation of the [BPS], and relates more to transmission access than reliable operations. The Commission disagrees that this modification relates primarily to transmission access. When the transmission operators know which component within the transmission element is limiting they have more information to inform their decisions about how to provide for the Reliable Operation of the [BPS]. Our proposed modification does not require any entity to invest in equipment to increase ratings of any facility; it simply requires the next limiting component of each facility to be identified in order to understand what components are causing the limits that are to be used in reliability mitigation assessments. The identification of the first limiting component is already an inherent requirement in the existing rating process. As clarified above, the modification to identify an increase in rating of the transmission element that would result from removing the first limiting component applies only to critical facilities whose thermal ratings have been reached causing an SOL or IROL condition. As Dominion highlights in its comments, this information is already identified in the planning processes of some RTOs and ISOs.”

864. “...“near-real time” system review by [RCs] may be more practical, while still being efficient and effective in achieving reliability goals. A proactive approach, i.e. one that involves RCs in a way that permits them to make wide-area assessments of composite interchange transactions for purposes of evaluating reliability impact, including identifying potential IROL violations and mitigating them using TLR procedures before they become actual IROL violations, is far superior to a reactive approach, i.e., one that brings RCs in after the fact to invoke TLR procedures to avoid an IROL violation or other operating actions to extricate the system from reliability problems such as an actual IROL violation.”

885. “The Commission believes that making a modification to an existing interchange schedule on paper for current or imminent reliability-related situations involving actual IROL violations is ineffective because its implementation usually takes much longer than the 30 minutes period that is allowed in the relevant IRO or TOP Reliability Standards. However, the Commission interprets INT-010-1 as allowing the actual physical transaction to be modified to alleviate an IROL event without first documenting the modification. The interchange schedule would then be modified after the fact to document the physical actions taken.”

886. “...the Commission clarifies that our concern is related to using interchange schedules to address actual IROL violations. We have no concern in using this as a tool help prevent potential SOL and IROL violations as asserted by ISO-NE. We further note that the phrase in Requirements R2 and R3 “current or imminent reliability-related reasons” can be interpreted as potential or actual IROL violations...and therefore modifications to INT-010-1 are needed.”

898. “When system integrity or reliability is jeopardized, e.g., exceeding IROLs or SOLs, the relevant reliability entities must take corrective control actions to return the system to a secure and reliable state as soon as possible and in no longer than 30 minutes. This is important to satisfy the relevant Reliability Standards such as IRO-005-0 and TOP-004-0 to minimize the amount of time the system operates in an insecure mode and is vulnerable to Cascading outages.”

926. “Our proposed directive is to augment the Requirement that the plans to alleviate SOL and IROL violations are assessed to ensure that the control actions can be implemented and effective within 30 minutes after a contingency.”

F300. “IRO-004-1 Purpose Statement states in part “Plans must be developed to alleviate SOL and IROL violations.””

929. “The proposed Reliability Standards IRO-005-1 and TOP-004-0 require that in the event of an IROL violation, i.e. power flow on an interface exceeding its IROL, the system must be returned to a secure state within 30 minutes regardless of the cause of the violation, so that the system is once again capable of withstanding the next contingency without resulting in Cascading failures.”

930. “...our intent is not to mandate an increase in security from N-1 to N-2, but rather is to ensure there is no reliability gap in the IROL-related Reliability Standards. To do this, the Commission believes it is necessary to provide operators with control actions needed to mitigate an IROL violation while within the 30 minute period after a first contingency. We are not requiring an increase to N-2, which would require planning the system for any two contingencies at all times.”

931. “...it is just as important for day-ahead operation planners to review and derive system operating limits to deal with a myriad of contingencies for different system configurations and generation dispatches, as it is for them to assess the feasibility of returning the system to a secure operating state after these contingencies have occurred. Similar to reviewing and deriving SOLs and IROLs to ascertain that system reliability will be maintained based on the most onerous forecast conditions and critical contingencies, identifying corrective control actions would not encompass each and every contingency and system condition. This is because previous operating experiences and established operating practices would have covered a significant portion of the contingencies and the corresponding control actions already.”

946. “The Commission clarifies the intent of and need for the proposed survey. We reiterate that the intent is to learn about the operating experiences and practices of operating entities; specifically, how they operate their systems to respect IROLs in the normal system conditions, i.e. prior to a contingency. The survey results will facilitate future development and modifications of IROL-related Reliability Standards to better clarify and eliminate potential multiple interpretations of respecting IROLs that may exist in the proposed Reliability Standards.³⁰³ In addition, the survey will identify the reliability risks and the frequency and number of operating practices involving drifting in and out of IROL.³⁰⁴ The survey results will also provide guidance on the frequency, duration and magnitude of IROL violations, their causes and whether these IROL violations occur during normal or contingency conditions.”

947. “...we note that the proposed Reliability Standards only require reporting on those violations that have exceeded IROLs for longer than 30 minutes. The current reporting requirements and results will not provide an adequate assessment of the existing operating practices regarding IROLs and the reliability risks and the extent of drifting in and out of IROLs.”

950. “The appropriate control actions to respect IROLs and SOLs are the responsibilities of a [RC] and [TOP]. If load shedding is required, it is the responsibility of a [RC] or a [TOP] to direct the appropriate entities including LSEs to carry it out.”

951. “Accordingly, the Commission approves Reliability Standard IRO-005-1 as mandatory and enforceable...The Commission further directs that the Measures and Levels of Non-Compliance specific to IROL violations must be commensurate with the magnitude, duration, frequency and causes of the violations and whether these occur during normal or contingency conditions. Finally, the Commission directs the ERO to conduct a survey on IROL practices and actual operating experiences by requiring [RCs] to report any violations of IROL, their causes, the date and time, the durations and magnitudes in which actual operations exceeds IROs to the ERO on a monthly basis for one year beginning two months after the effective date of the Final Rule. We may propose further modifications to IRO-005-1 based on the survey results.”

1393. “...the Commission approves Reliability Standard PER-002-0...the Commission directs the ERO to develop a modification to PER-002-0 through the Reliability Standards development process that...(3) expands the Applicability section to include (a) [RCs], (b) local transmission control center operator personnel (as specified in the above discussion), (c) [GOPs] centrally-located at a generation control center with a direct impact on the reliable operation of the [BPS] and (d) operations planning and operations support staff who carry out outage planning and assessments and those who develop SOLs, IROs or operating nomograms for real-time operations; (4) uses the Systematic Approach to Training (SAT) methodology in its development of new training programs and (5) includes the use of simulators by [RCs], [TOPs] and [BAs] that have operational control over a significant portion of load and generation.”

1438. “In the case, however, of a system element protected by a single protection system with a failed relay that threatens system reliability, that scenario would require the use of appropriate operating solutions including removing a system element from service. Another possible solution is to operate a system at a lower SOL or IROL that recognizes the degraded protection performance.”

1608. “As we explained in the NOPR, TOP-002-2 serves an important purpose in ensuring that resources and operational plans are in place to enable system operators to maintain the [BPS] in a reliable state...Accordingly, the Commission approves Reliability Standard TOP-002-2... [and] directs the ERO to develop a modification to TOP-002-2...that...(2) requires the next-day analysis for all IROs to identify and communicate control actions to system operators that can be implemented within 30 minutes following a contingency to return the system to a reliable operating state and prevent Cascading outages...”

¶1637. “We disagree...that TOP-007-0 covers reporting of “drifting” in and out of IROL violations because that Reliability Standard only requires reporting of IROL violations exceeding 30 minutes...we believe a survey is appropriate to determine actual practices, and simply modifying the compliance reporting procedures may not provide sufficient data to determine the reliability impacts of such practices and whether a modification to the Reliability Standard is appropriate. Accordingly, we direct the ERO to conduct a survey on the operating practices and actual experiences surrounding drifting in and out of IROL violations.”

1855. “Since a [RC] is the highest level of authority overseeing the reliability of the [BPS], the Commission believes that it is important to include the [RC] as an applicable entity to assure that adequate voltage and reactive resources are being maintained...other Reliability Standards address responsibilities of [RCs], but we agree...that it is important to include [RCs] in VAR-001-1 as well. [RCs] have responsibilities in the IRO and TOP Reliability Standards, but not the specific responsibilities for voltage levels and reactive resources addressed by VAR-001-1, which have a great impact on system reliability. For example, voltage levels and reactive resources are important factors to ensure that IROs are valid and operating voltages are within limits, and that [RCs] should have responsibilities in VAR-001-1 to monitor that sufficient reactive resources are available for reliable system operations. Accordingly, the ERO should modify VAR-001-1 to include [RCs] as applicable entities and include a new requirement(s) that identifies the [RC’s] monitoring responsibilities.”

1876.”With respect to MidAmerican’s suggestion of exempting areas that are not susceptible to voltage instability from the requirement to perform voltage stability analysis, the Commission notes that such exemption is not

appropriate. We draw an analogy between transient stability limits and voltage stability limits. The requirement to perform voltage stability analysis is similar to existing operating practices for IROLs that are dictated by transient stability. Transient stability IROLs are determined using the results of off-line simulation studies, and no areas are exempt. In real-time operations, these IROLs are monitored to ensure that they are not violated. Similarly, voltage stability is conducted in the same manner, determining limits with off-line tools and monitoring limits in real-time operations. Areas that are susceptible to voltage instability are expected to run studies frequently, and areas that have not been susceptible to voltage instability are expected to periodically update their study results to ensure that these limits are not encountered during real-time operations.”

FERC NOPR Leading to Order No. 705 in Docket RM07-3-000 (Issued August 13, 2007)⁶⁶

41. “With respect to NERC’s proposed definition of IROL, the Commission identified in Order No. 693 that the statutory definition of Reliable Operation is to assure that the system is operated within thermal, voltage and stability limits such that instability, uncontrolled separation, or cascading failures will not occur. IROLs are a specific subset of the operating limits at which instability, Uncontrolled separation, or cascading failures may occur. All IROL violations will have an adverse impact on the reliability of the bulk electric system.”

42. The definition of IROL in the approved NERC glossary is “The value (such as MW, MVAR, Amperes, Frequency or Volts) derived from, or a subset of the System Operating Limits, which if exceeded, could expose a widespread area of the Bulk Electric System to instability, uncontrolled separation(s) or cascading outages.” The revised definition is consistent with the intent of the statute with the exception of the phrase “that adversely impacts the reliability of the bulk electric system.” This may give the impression that violation of some IROLs that do not adversely impact the reliability of the bulk electric system are acceptable. The Commission proposes to accept the definition in FAC-014 with the understanding that all IROLs impact bulk electric system reliability.

43. [...] The Commission proposes to accept the definition in FAC-014 with the understanding that the only time it is acceptable to violate an IROL is in the limited time after a contingency has occurred and the operators are taking action to eliminate the violation.

FERC Order No. 705 (Issued December 27, 2007)⁶⁷

53. “In Order No. 693, the Commission noted that “allowing for the 30 minute system adjustment period, the system must be capable of withstanding an N-1 contingency, with load shedding available to system operators as a measure of last resort to prevent cascading failures. Order No. 693 stated that the transmission system should not be planned to permit load shedding for a single contingency.”

93. “the Commission has stated that regional differences are permissible if they are either more stringent than the continent-wide Reliability Standard or if they are necessitated by a physical difference in the [BPS].”

111. The Commission did not adopt the proposed interpretation of Cascading Outages. Rather, they remanded the definition, stating that “NERC may refile a revised definition that addresses our concerns.”

112. The Commission stated concerns with removing “the qualifying language “by studies””, which “would allow an entity to identify a “predetermined area” based on considerations other than engineering criteria. For example, under the proposed definition of Cascading Outages, an entity could predetermine that an outage could spread to

⁶⁶ Facilities, Design, Connections and Maintenance Mandatory Reliability Standards, Notice of Proposed Rulemaking, 72 FR 160 (Aug. 20, 2007), FERC Stats. And Regs. ¶ 32,622 (Aug. 13, 2007). Available: <https://www.ferc.gov/CalendarFiles/20070813182314-RM07-3-000.pdf>.

⁶⁷ Facilities Design, Connections and Maintenance Reliability Standards, 18 CFR Part 40, Docket No. RM07-3-000, Order No. 705 (Issued August 13, 2007). Available: <https://www.ferc.gov/CalendarFiles/20070813182314-RM07-3-000.pdf>

the edge of its footprint without considering the event to be a Cascading Outage. The Commission is concerned that the limits placed on outages should be determined by sound engineering practices.”

113. Ambiguity between the definition of Cascading and the proposed definition of Cascading Outages were addressed, stating that NERC “did not explain any distinction between the two terms. Nor did NERC explain why the new term is necessary and requires a separate definition.”

114. “If NERC decides to propose a new definition of Cascading Outages, the commission would expect any proposed definition to be defined in terms of an area determined by engineering studies, consistent with the definition of Cascading. In addition, the Commission is concerned with the consistent, objective development of criteria with which the “pre-determined area” would be determined. Therefore, the Commission suggests that NERC develop criteria, to be found in a new Reliability Standard or guidance document, that would be used to define the extent of an outage, beyond which would be considered a Cascading Outage.”

123. “As proposed in the NOPR, the Commission accepts NERC’s definition of IROL.”

128. “The Commission approves NERC’s proposed definition of IROL Tv...”

173. “The Commission agrees with NERC that FAC-014-1, Requirement R5 is not aimed at the prevention and/or mitigation of IROLs, but rather the communication of SOL and IROL information...the Commission believes that this Requirement applies to both real-time operations and the planning time frames, by ensuring that inter-dependent IROLs in adjacent footprints are duly considered in the planning time frame and timely remedial actions are taken in real-time operation.”

174. “Ineffective communication was identified as a factor common to the August 2003 blackout and other previous major blackouts.”

175. “...the communication of those limits to those with a reliability related need, ensures the protection of [BPS] facilities, thus preventing Cascading failures of the interconnected grid...”

FERC Order No. 748 (Issued March 17, 2011)⁶⁸

40. “NERC and others suggest that these Reliability Standards are not intended to remove all responsibility for the analysis and monitoring SOLs from the RC. We agree. These Standards generally establish a clear distinction of primary responsibility for SOLs and IROLs between the [TOP] and [RC] respectively. As NERC notes, however, the [RC] will continue to have the ability and the responsibility to analyze and monitor SOLs that could turn into IROLs.”

41. “...IRO-002-2 continues to require each [RC] to monitor SOLs other than IROLs both within its [RC] area and in surrounding [RC] areas.”

42. “...as noted by NERC and other commenters, there exists a subset of “grid-impactive” SOLs other than IROLs that the Commission believes may warrant closer analysis by the [RC], in addition to the analysis being conducted by the [TOP], that focuses on whether these particular “grid-impactive” SOLs could become IROLs. The Commission believes that there can be considerable benefit derived from some overlap in the responsibility for analyzing and monitoring these “grid-impactive” SOLs since, by definition, every IROL emanated from an SOL.”

44. “...to determine whether a need exists to further refine the delineation of responsibilities between the [RC] and [TOP] for analyzing a class of “grid-impactive” SOLs.”

⁶⁸ Mandatory Reliability Standards for Interconnection Reliability Operating Limits, 18 CFR Part 40, Docket No. RM10-15-000, Order No. 748 (Issued March 17, 2011). Available: <https://legacyexternalwebsitefiles.balch.com/upload/Order%20748.pdf>.

55. The Commission approved IRO-009-1, mentioning that the NERC Reliability Coordinator Working Group should further study this issue and determine if there is a need for [RCs] to have action plans developed and implemented with respect to certain grid-impactive SOLs.”

Order 802 (Issued November 20, 2014)⁶⁹

10. “Requirement R1 [of CIP-014-1] requires applicable [TOs] to perform risk assessments on a periodic basis to identify their transmission stations and transmission substations that, if rendered inoperable or damaged, could result in widespread instability, uncontrolled separation, or cascading within an Interconnection.”

31. “The Commission...directs NERC to remove the term “widespread” from Reliability Standard CIP-014-1 or, alternatively, to propose modifications to the Reliability Standard that address the Commission’s concerns. The differing views expressed in the comments validate the concern raised in the NOPR that the meaning of the term “widespread” is unclear and subject to interpretation.”

32. We stated in the March 7 Order that “the Reliability Standards that we are ordering today apply only to critical facilities that, if rendered inoperable or damaged, could have a critical impact on the operation of the interconnection through instability, uncontrolled separation or cascading failures on the Bulk-Power System. We affirm the March 7 Order’s statement that “[m]ethodologies to determine these facilities should be based on objective analysis, technical expertise, and experienced judgment.”

33. However, incorporating the undefined term “widespread” in Reliability Standard CIP-014-1 introduces excessive uncertainty in identifying critical facilities under Requirement R1. As the Commission stated in the March 7 Order, only an instability that has a “critical impact on the operation of the interconnection” warrants finding that the facility causing the instability is critical under Requirement R1. The March 7 Order did not intend to suggest that the physical security Reliability Standards should address facilities that do not have a “critical impact on the operation of the interconnection.” This understanding is, we believe, unintentionally absent in Requirement R1 because the requirement only deems a facility critical when, if rendered inoperable or damaged, it could result in widespread instability, uncontrolled separation, or Cascading within an Interconnection. The definition in Requirement R1 should not be dependent on how an applicable entity interprets the term “widespread” but instead should be modified to make clear that a facility that has a critical impact on the operation of an Interconnection is critical and therefore subject to Requirement R1.

FERC Remand NOPR (Dockets RM13-12-000, RM13-14-000) (Issued November 21, 2013)⁷⁰

51. The Commission was concerned with “NERC’s proposal because, unlike the currently-effective TOP Reliability Standards, the proposed standards do not require the [TOP] to plan and operate within SOLs, only non-IROL SOLs that are identified by the [TOP] as supporting reliability internal to its area and identified as a result of an [OPA]. For example, non-IROL SOLs that appear to be excluded from the proposed standard are non-IROL SOLs that are in a [TOP’s] area that impact another [TOP’s] area or more than one [TOP’s] area.”

52. “During deteriorating system conditions, an SOL can rapidly degrade into an IROL. Limiting the requirement for [TOPs] to analyze and operate within SOLs only to non-IROL SOLs identified by the [TOP] for its internal area can

⁶⁹ Physical Security Reliability Standard, 18 CFR Part 40, Docket No. RM14-15-000, Order No. 802 (Issued November 20, 2014). Available: <https://www.ferc.gov/whats-new/comm-meet/2014/112014/E-4.pdf>.

⁷⁰ Monitoring System Conditions – Transmission Operations Reliability Standard, Transmission Operations Reliability Standards, Interconnection Reliability Operations and Coordination Reliability Standards, 18 CFR Part 40, Docket Nos. RM13-12-000, RM13-14-000, and RM13-15-000, Notice of Proposed Rulemaking (Issued November 21, 2013). Available: <https://www.ferc.gov/whats-new/comm-meet/2013/112113/E-3.pdf>.

reduce system reliability because operators have less situational awareness of the system and conditions. Even if we accept the argument that our rules for operating bulk electric facilities should not be concerned with “equipment damage or [element] loss of life,” NERC has not explained adequately why the only “true reliability requirement is to operate within IROLs and that non-IROL SOLs are a local operating issue.” Major Cascading events including the Northeast Blackout of 2003 and the 2011 Southwest Outage were initiated by a non-IROL SOL exceedance, followed by a series of non-IROL SOLs exceedances until the system entered a sequence of Cascading events. Thus, while non-IROL SOLs are essentially defined as not posing a risk of Cascading outages, instability or uncontrolled separation if they are exceeded, experience indicates that operators do not always foresee the consequences of exceeding such SOLs and thus cannot be sure of preventing harm to reliability. The Commission believes that when any facility ratings or stability limits are exceeded or expected to be exceeded (i.e. causing a SOL or an expected SOL on jurisdictional facilities), these conditions should be mitigated to avoid the possibility of further deteriorating system conditions and a cascade event.”

53. “We recognize that, if IROLs and non-IROL SOLs are determined accurately, the reliability consequences of an exceedance should usually be greater for the former than the latter.”

54. “...the [TOP] should have an operational plan to operate within all [BPS] IROLs and SOLs for all cases when facility ratings or stability limits are exceeded during anticipated normal and contingency event conditions. The operational plan is needed to ensure the [TOP] operates in, or can return its system to, a reliable operating state. For example, the 2011 Southwest Outage Blackout Report raised a similar concern, stating that [TOPs] should “ensure that post-contingency mitigation plans reflect the time necessary to take mitigating actions, including control actions, to return the system to secure N–1 state as soon as possible but no longer than 30 minutes following a single contingency.” We believe that the [TOP] should have operational or mitigation plans for all [BPS] IROLs and SOLs that can be implemented within 30 minutes or less to return the system to a secure state. Absent such plans, system conditions can linger in an unsecure or emergency state exposing the system to Cascading outages upon the next contingency.”

55. “...TOP–001–2, Requirements R8 through R11 address [TOP] notification, operation and action with respect to IROLs and some SOLs based on the transmission operator’s next-day [OPA]. Because proposed Reliability Standard TOP–001–2, Requirement R8 requires a [TOP’s] notification of only those SOLs identified in a next-day [OPA], the Commission believes it is possible for additional SOLs to develop or occur in the same-day or real-time operational time horizon. This could impose an operational risk to the interconnected transmission network...there are various reasons why a SOL could occur in real-time operations due to the dynamic nature of the real-time interconnected transmission network and not be identified in the next-day [OPA]. To assure that [TOPs] are equipped to react to such situations, we believe that the Requirement R8 operational responsibilities and actions should pertain to all IROLs and all SOLs for all operating time horizons.”

56. The Commission remanded proposed Reliability Standards TOP–001–2 and TOP–002–3 and directed NERC to modify standards requirements “to ensure that [TOPs] develop mitigation plans for all IROLs and SOLs expected to be exceeded.” The Commission also directed NERC modify the standards to “require that [TOP] actions apply to all SOLs identified in all operational time horizons (operations planning, same-day operations and real-time operations)” as well as “require that [TOP] specified actions apply to all SOLs related responsibilities in the real-time operations time horizon.”

FERC Order No. 817 (Issued November 19, 2015)⁷¹

27. “While it appears that regional discrepancies exist regarding the manner for calculating IROLs, we accept NERC’s explanation that this issue is more appropriately addressed in NERC’s Facilities Design, Connections and

⁷¹ Transmission Operations Reliability Standards and Interconnection Reliability Operations and Coordination Reliability Standards, 18 CFR Part 40, Docket No. RM15-16-000, Order No. 817 (Issued November 19, 2015).

Maintenance or “FAC” Reliability Standards. NERC indicates that an ongoing FAC-related standards development project - NERC Project 2015-09 (Establish and Communicate System Operating Limits) - will address the development and identification of SOLs and IROLs. We conclude that NERC’s explanation, that the Project 2015-09 standard drafting team will address the clarity and consistency of the requirements for establishing both SOLs and IROLs, is reasonable. Therefore, we will not direct further action on IROLs in the immediate TOP and IRO standard-related rulemaking. However, when this issue is considered in Project 2015-19, the specific regional difference of WECC’s 1,000 MW threshold in IROLs should be evaluated in light of the Commission’s directive in Order No. 802 (approving Reliability Standard CIP-014) to eliminate or clarify the “widespread” qualifier on “instability” as well as our statement in the Remand NOPR that “operators do not always foresee the consequences of exceeding such SOLs and thus cannot be sure of preventing harm to reliability.”

68. “...valid operating limits, including transient stability limits, are essential to the reliable operation of the interconnected transmission network and that a [TOP] must not enter into an unknown operating state.”

70. “[TOPs] must perform a [RTA] at least once every 30 minutes...the establishment of transient stability operating limits is adequately addressed [through the TOP and FAC standards]...”

Appendix B: Examples of Instability Analysis

This section provides illustrative examples of types of instability, including system instability, and the analysis methods and considerations that may be used in the determination of whether an IROL should be established.

Example of System Voltage Instability during Contingency Analysis

Figure B.1 shows an example system of a large metropolitan area⁷² with multiple element outages (the assumed combination of planned and forced outages). In the precontingency operating state, voltages are moderately depressed but within acceptable system voltage limits. However, voltages collapse across many buses post-contingency after a 500 kV line trips that is serving the load area. Contingency analysis results in a diverged powerflow solution, and a “soft outage” approach to the contingency (see Chapter 5: Cascading Analysis Assessment Techniques, section “Divergent Powerflow and “Soft Outages” Considerations”) confirms that the voltage collapse is not simply numerical instability—the collapse is a credible post-contingency result. At this point, the engineer studying this area should decide if further investigation is warranted to determine if the voltage collapse is contained. If further analysis is not performed to prove containment, then the instability should be classified as system instability and an IROL should be established since the amount of affected generation and/or load is not quantifiable.

Figure B.2 shows the results of the “soft outage” approach just prior to the point of voltage instability—the impedance of the outaged line is increased up to the point of collapse and the results are analyzed at this point. Bus voltages in the metro area are depressed across the lower nominal voltage buses while the 500 kV backbone maintains voltages near nominal. A visual boundary appears to be observable in the solution results obtained. However, a visual boundary of low voltage is not sufficient technical evidence to prove containment of a voltage collapse. Evidence is needed to prove that protection systems would operate during the collapse to separate the collapsing system from the rest of the network. In addition, assumptions on load dropping may also be incorporated, but voltages should be proved to be low enough to warrant some form of voltage-based tripping of load.

In this example, depressed voltages (around 0.88 pu) immediately before the simulated collapse are observed across many buses in the metropolitan area. Current flow into the area is insufficiently high enough to demonstrate actuation of protective relaying. Since voltages are depressed across a widespread area of the metropolitan area, and the simulation is unable to clearly demonstrate protective relay actuation to separate the collapsing voltage, this situation should be classified as system instability.

⁷² This system was stressed beyond realistic planning conditions to illustrate the concept of voltage instability assessment unit contingency analysis.

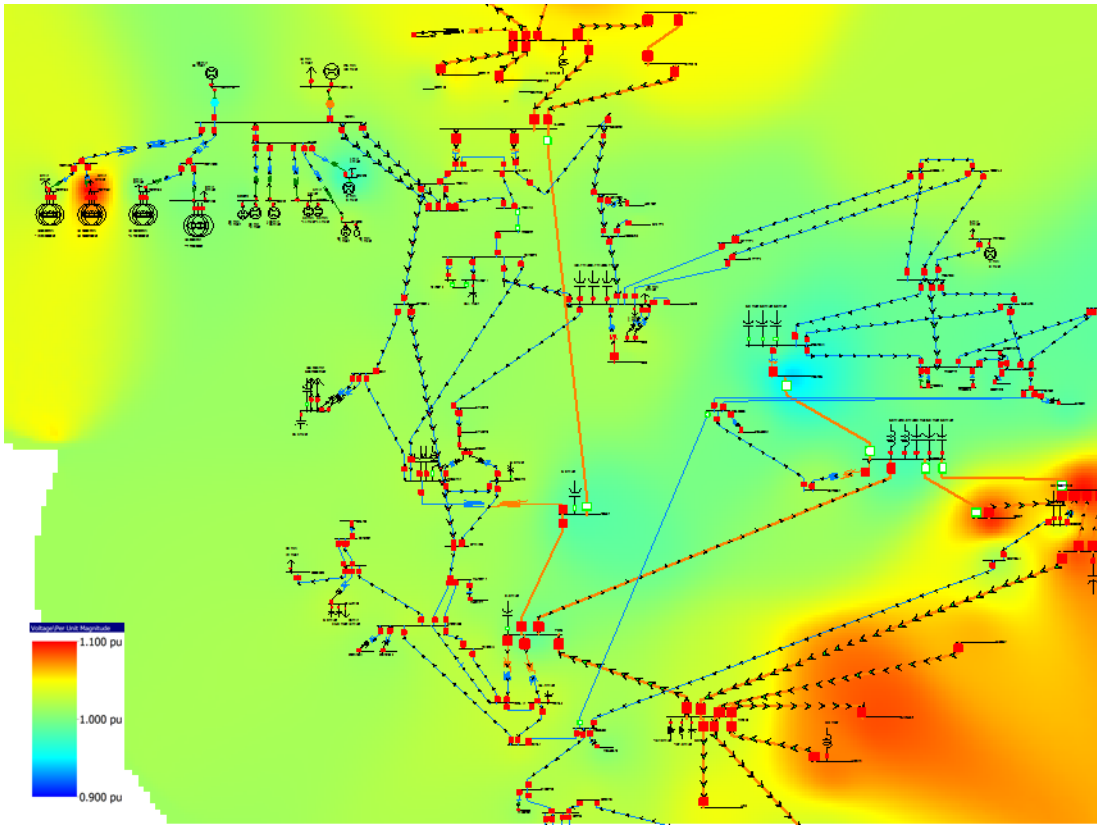

Figure B.1: Pre-Contingency Voltages for Example Large Load Area Voltage Collapse

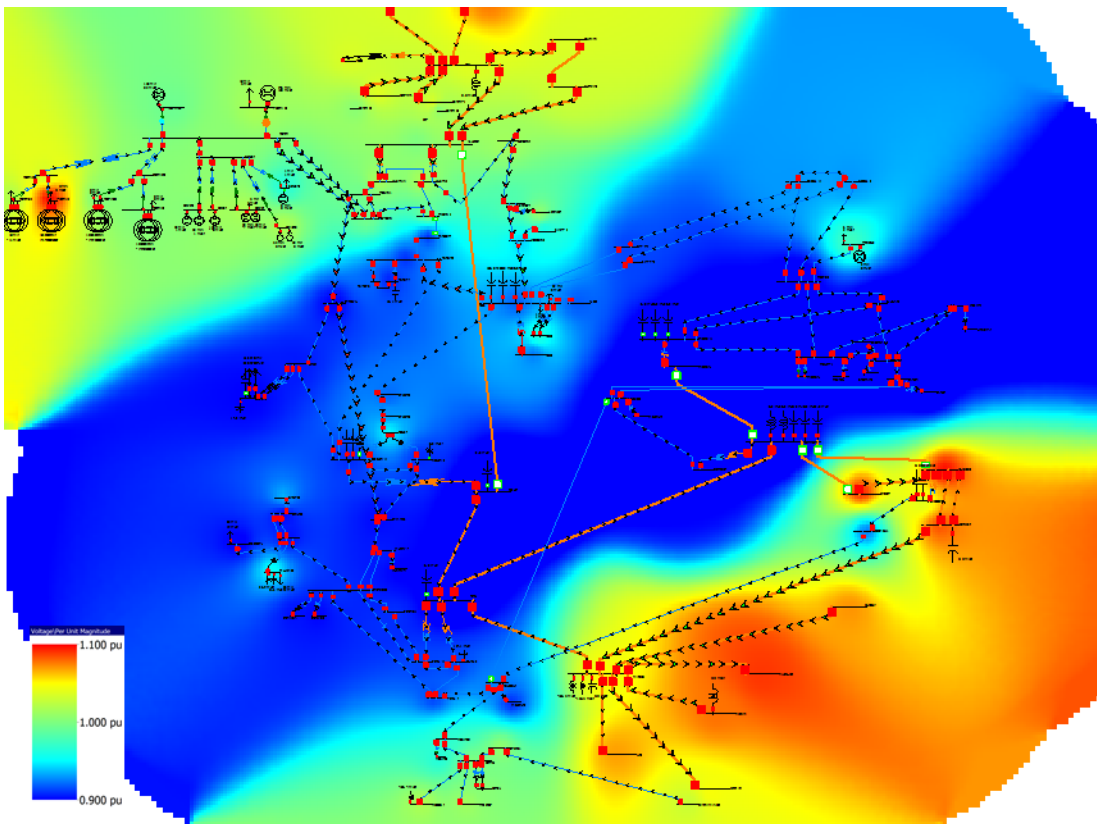

Figure B.2: Post-Contingency Voltages for System Voltage Instability Example

Example of Transient Voltage Instability Analysis

Figure B.3 shows bus voltage magnitudes at 345 kV buses for a severe contingency in the New England system. The study shows that bus voltages recover and oscillations damp acceptably; however, a transient voltage response criteria⁷³ is violated due to the prolonged voltage below 0.8 pu during the first couple swings. While this may be deemed unacceptable performance criteria, the resulting conditions do not result in system instability and an IROL would not be established. A proxy (interface) SOL should be established to monitor these marginally stable transient voltage stability conditions. However, transient voltage instability is a highly asymptotic form of instability and the potential for an IROL past the established SOL should be explored.

Figure B.4 shows generator rotor angles for key generators in the same area. The same fault is applied to this system, which is now stressed an additional 50 MW at the most critically located single plant within the constrained area. With the increase in export from the area, multiple generating units lose synchronism and adversely impact stability of the entire area. **Figure B.5** shows the transient voltage collapse for system bus voltages across the area. Voltage drops well below 0.7 pu within two seconds of the fault, which results in loss of an entire area and, in the second transient swing, remote generation. Due to the impact to neighboring RC areas, the large loss of generation and load in the studied area, and the inability to identify a clear boundary of affected buses experiencing this instability, this should be considered system instability and an IROL should be established to protect against these conditions.

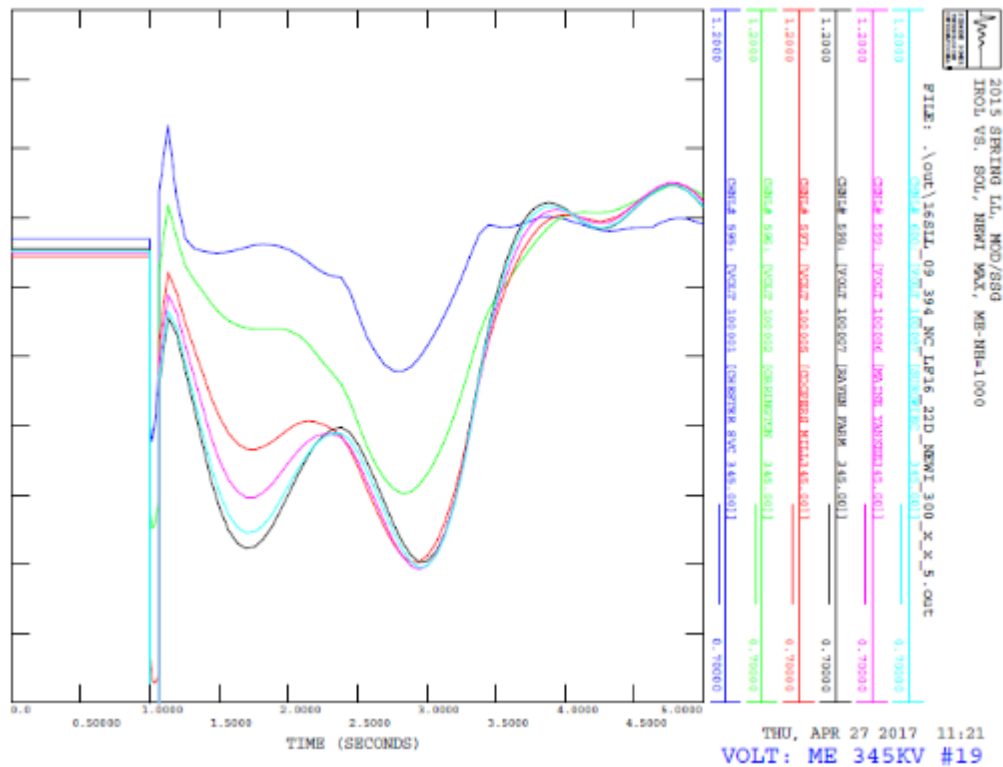

Figure B.3: Example of Unacceptable Transient Voltage Performance

⁷³ Transient voltage response criteria are frequently established to mitigate potentially undesirable system events such as loss of load due to low voltage (including loss of key power plant auxiliary loads, which will in turn cause loss of the power plant) and potential inadvertent actuation of relays on power swings. If transient voltage response exceedances occur at a generating unit's terminals or point of interconnection, unit instability or system instability may ensue for slight increases in system stress (i.e. more power output from the plant or power transfer through the stressed interface).

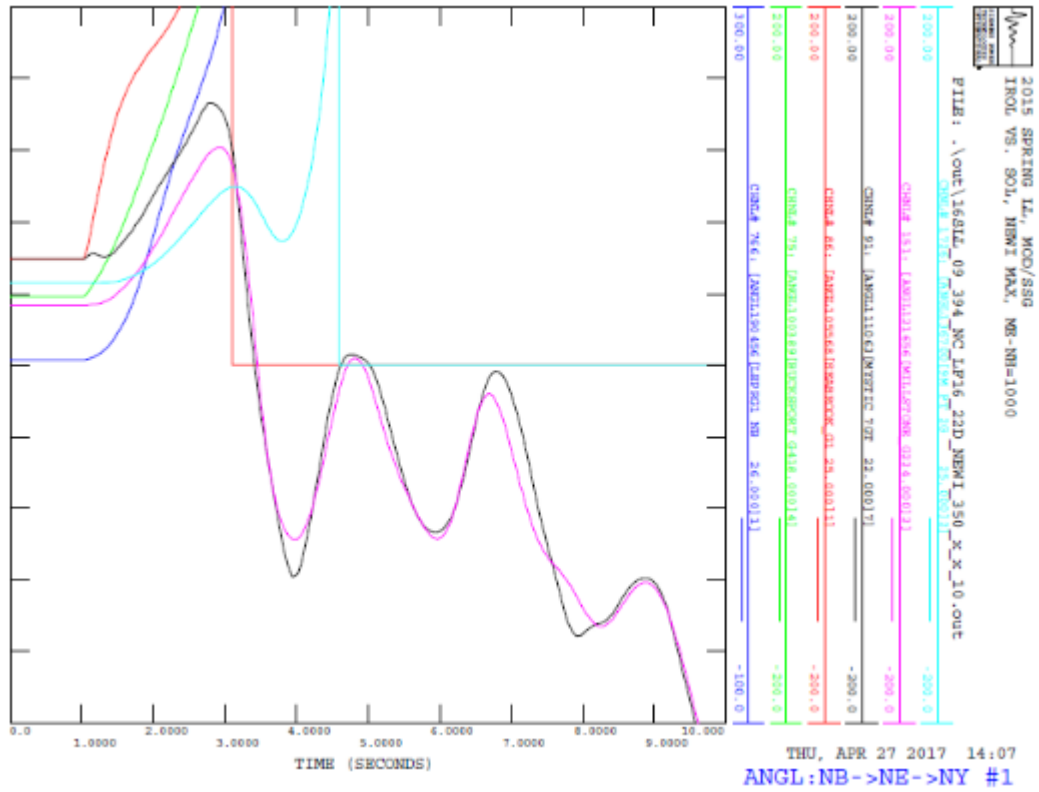

Figure B.4: Example of Rotor Angles for Transient Voltage Collapse Case – System Instability

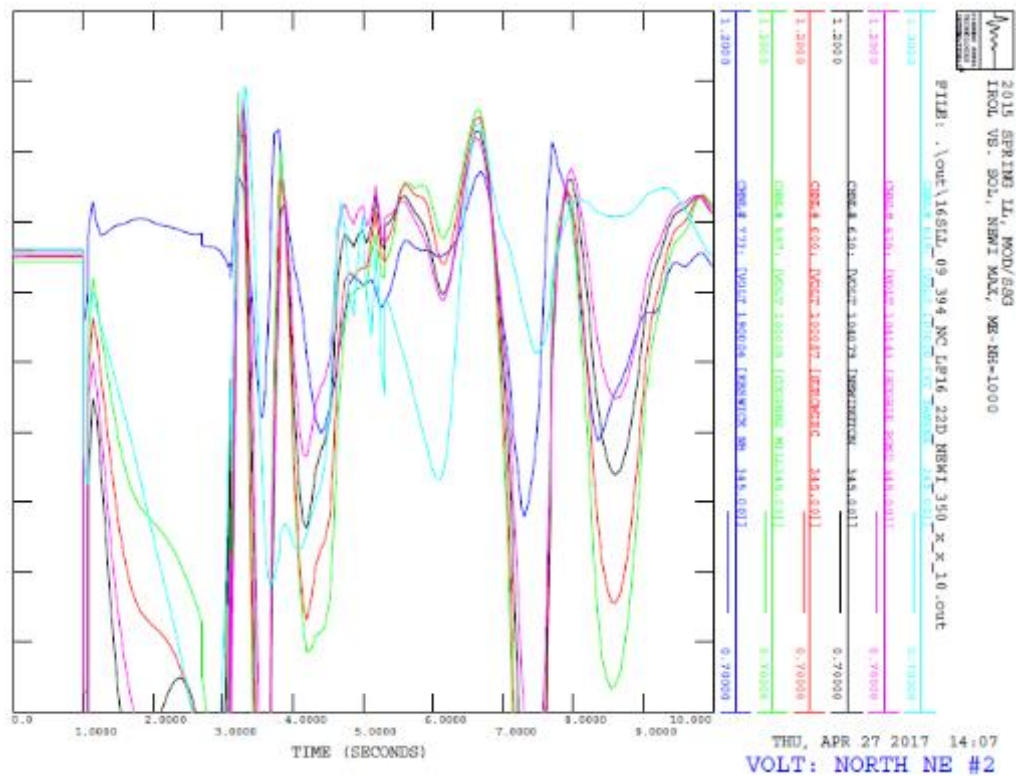

Figure B.5. Example of Bus Voltages for Transient Voltage Collapse Case – System Instability

Example of Unit Instability Analysis

Figure B.6 shows an example system configuration of a unit connected to a BES substation that includes four transmission circuits. One transmission circuit is out of service for planned maintenance. Prior to the transmission line being removed from service for planned maintenance, a stability assessment was conducted as part of the development of an OPA. The stability assessment used conservative assumptions associated with expected transmission system conditions (e.g., expected demand levels, generation dispatch pattern, expected planned and forced outages, expected transfers).

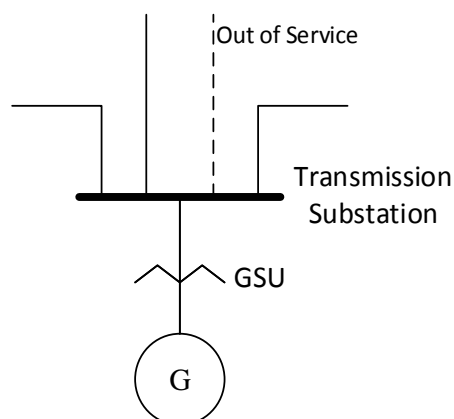

Figure B.6: Generating Unit Connection to BES, One Transmission Circuit Out of Service

The stability assessment resulted in the identification of an SOL in the form of a limit on the plant (unit) MW output that is less than the normal maximum MW output rating for the unit. Figure B.7 shows a plot of the rotor angle of the unit for the worst single contingency at the unit's SOL, demonstrating both marginal transient and dynamic (acceptable damping) stability. The unit is expected to maintain marginal stability for the SOL; however, stability is maintained. Some entities that perform stability assessments may apply additional time to the expected design fault clearing. This practice provides margin in case actual system conditions turn out to be more onerous than what was studied in setting the SOLs.

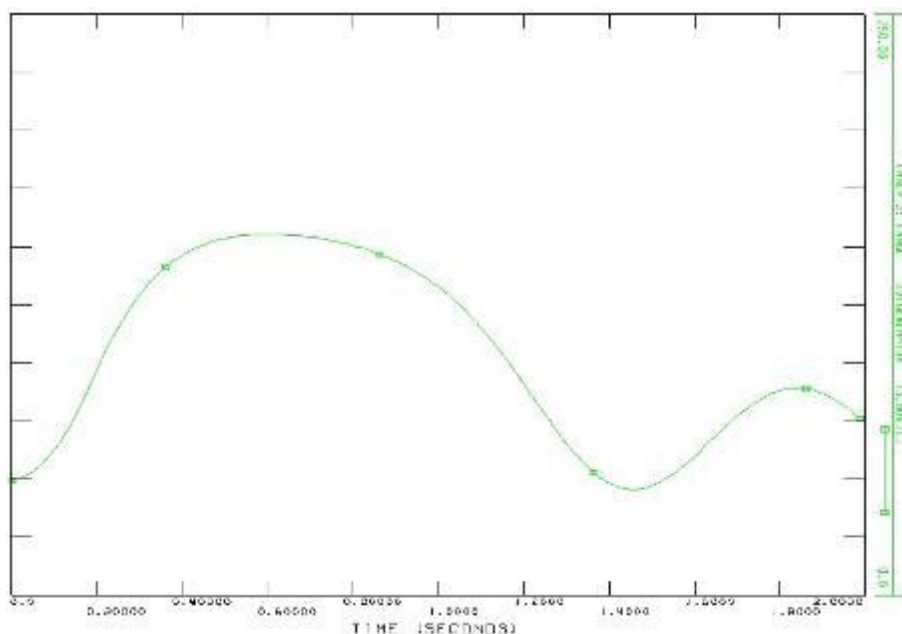

Figure B.7: Marginally Stable Rotor Angle Plot for Worst Contingency at SOL

[Source: Southern Company]

Figure B.8 shows the unstable response of the same unit for the same contingency when the unit is operating just slightly past the SOL. While the rotor angle plot clearly shows that the unit did not maintain stability, it does not by itself demonstrate whether or not the instability should be classified as system instability. Expected out of step protection was modeled using a mho characteristic at the high side of the unit’s GSU looking towards the GSU and the unit (see Figure B.9). The impedance swing for the unstable rotor angle plot clearly shows the impedance swing entering into the out of step characteristic. This sequence of events was further confirmed by monitoring the stability log file (see example in Figure B.10), which contains records from the generic out of step model in “report mode” confirming the impedance swing entered into the “Zone 1” region of the GSU protection.

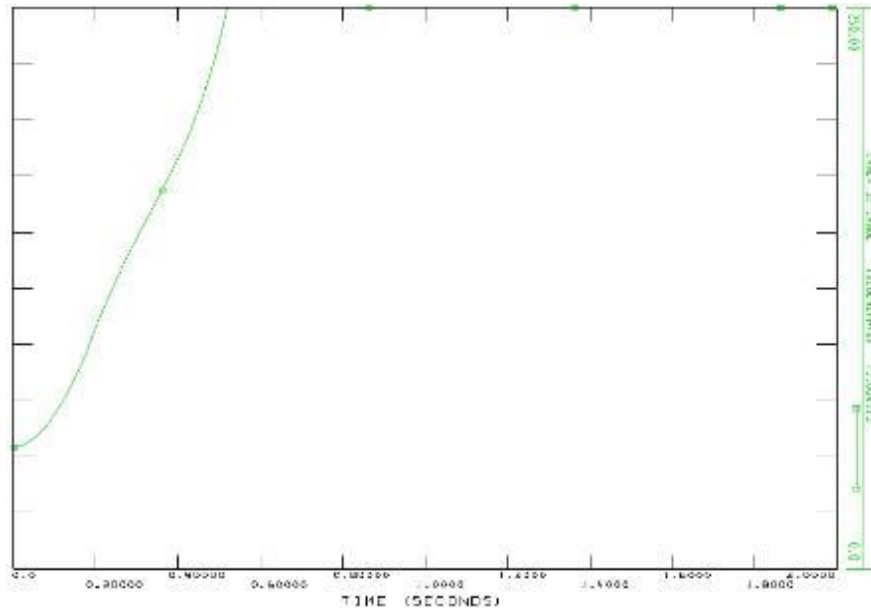

Figure B.8: Unstable Rotor Angle for Worst Contingency with Output Exceeding SOL
 [Source: Southern Company]

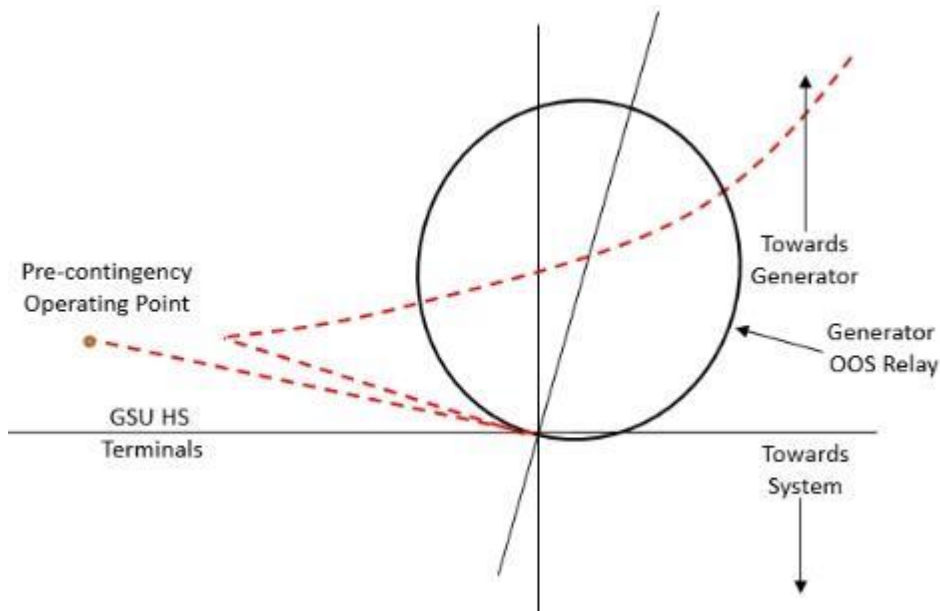

Figure B.9: RX Diagram and Impedance Swing Relative to Out of Step Relay with Unit Exceeding SOL
 [Source: Southern Company]

RELAY SCAN ALARMS AT TIME = 0.2000:

X----- F R O M -----X X----- T O -----X

BUS# X-- NAME --X BASKV BUS# X-- NAME --X BASKV CKT CIRCLE MW MVAR VOLTAGE

1234 BUS#1 230.00 5678 BUS#2 18.00 1 A 103.9 1679.5 0.3989

Figure B.10: Example Out of Step Relay Scan from Simulation Log File

[Source: Southern Company]

The impedance swing clearly shows that the out of step relay would operate and trip the unit for the unstable conditions. Furthermore, the apparent impedance swing does not enter “into the transmission system,” and therefore, it can be concluded that the instability would not propagate into the transmission system. An additional simulation was performed that included tripping the unit upon instability, and the resulting system conditions were stable and within allowable limits (e.g., voltage magnitudes and thermal loading). With clear justification that the instability is contained to the local unit, this instability should not be classified as system instability and no IROL should be established. The unstable operating conditions should be managed by an SOL.

An additional step was taken to confirm that the instability should not be classified as system instability by taking the unit to full output and performing the same analysis. The intent of performing the additional simulation was to determine if, at the maximum possible SOL exceedance, the worst case contingency would be expected to cause system instability that could merit the establishment of an IROL. Again, the impedance swing was observed and showed that it did not enter “into the system” and the unit would be tripped (see [Figure B.11](#)). Stable and acceptable conditions were obtained following tripping the unit for this instability as well.

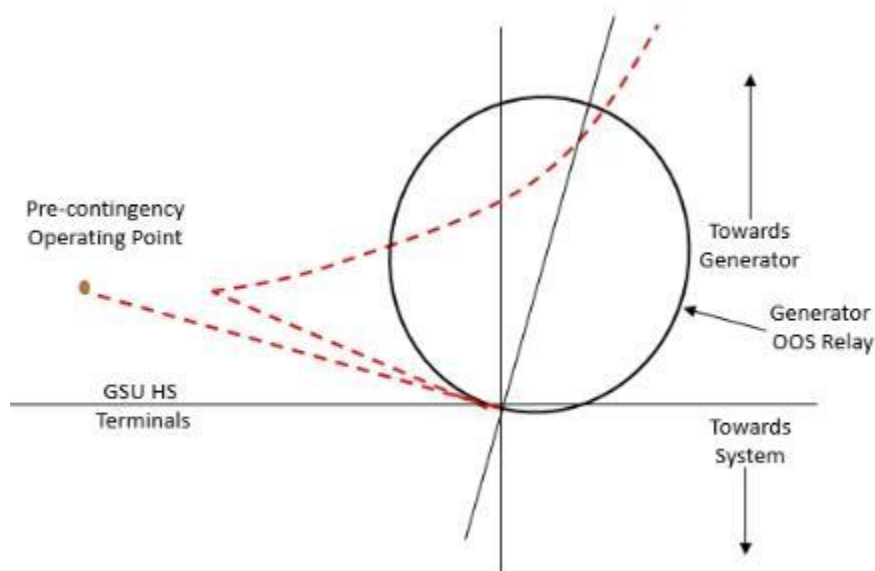

Figure B.11: RX Diagram and Impedance Swing with Unit at Maximum SOL Exceedance

[Source: Southern Company]

Appendix C: Examples of Uncontrolled Separation Analysis

This section presents examples of analyzing system separation and determining if the separation is considered uncontrolled separation or controlled separation.

Alberta-British Columbia Separation Scheme

Alberta Electric System Operation (AESO) is connected to the Western Interconnection through four lines: one 500 kV line and two 138 kV lines to BC Hydro, and one 230 kV line connecting Alberta to Montana. AESO demand is approximately 10 percent of the total Western Interconnection demand, and the studied light spring demand for the Western Interconnection is 92.7 GW. AESO is importing 750MW prior to the separation event, which is initiated by a fault on the 500 kV line between AESO and BCHA.

Figure C.1–Figure C.4 show two bus voltages and frequencies for two different scenarios. One involves controlled separation based on control system action operating as designed and planned, and the other involves uncontrolled separation where several layers of controlled separation protection schemes have been disabled (to illustrate the impact of the uncontrolled separation).

- **Controlled Separation:** Following the 500 kV line outage, a direct transfer trip signal is sent to trip the transmission line between AESO and Montana. A transfer trip signal is also sent to open the two 138 kV lines. Following the controlled separation, frequency in the Western Interconnection increases slightly as the area now has a slight generation surplus. The AESO island experiences a frequency decline since it is deficient in generation. However, frequency stability in both islands is maintained since sufficient governor action and primary frequency response is able to arrest these frequency deviations. Voltages at the points of separation drop to about 0.75 pu where relays are designed to trip the line.
- **Uncontrolled Separation:** The 500 kV line is removed due to the contingency. Transfer trip is initiated and the Montana tie is disconnected. However, the relay that completes the controlled separation by disconnecting the two 138 kV lines does not operate (in this example). Instead, the AESO remains connected to the Western Interconnection through these 138 kV lines. Frequency in AESO declines and oscillates, and voltages and power flows at the ties between the two areas experience large magnitude sustained oscillations. The oscillations persist and there is no purposeful protection operation to complete the separation. This is because the Zone 2 relays that would likely trip for this sustained oscillatory behavior are not modeled in the simulation. As a result, the oscillation begins to propagate into the rest of the Western Interconnection, leading to system instability since it is unclear which relays would operate exactly and what the consequences or extent of the instability would be.

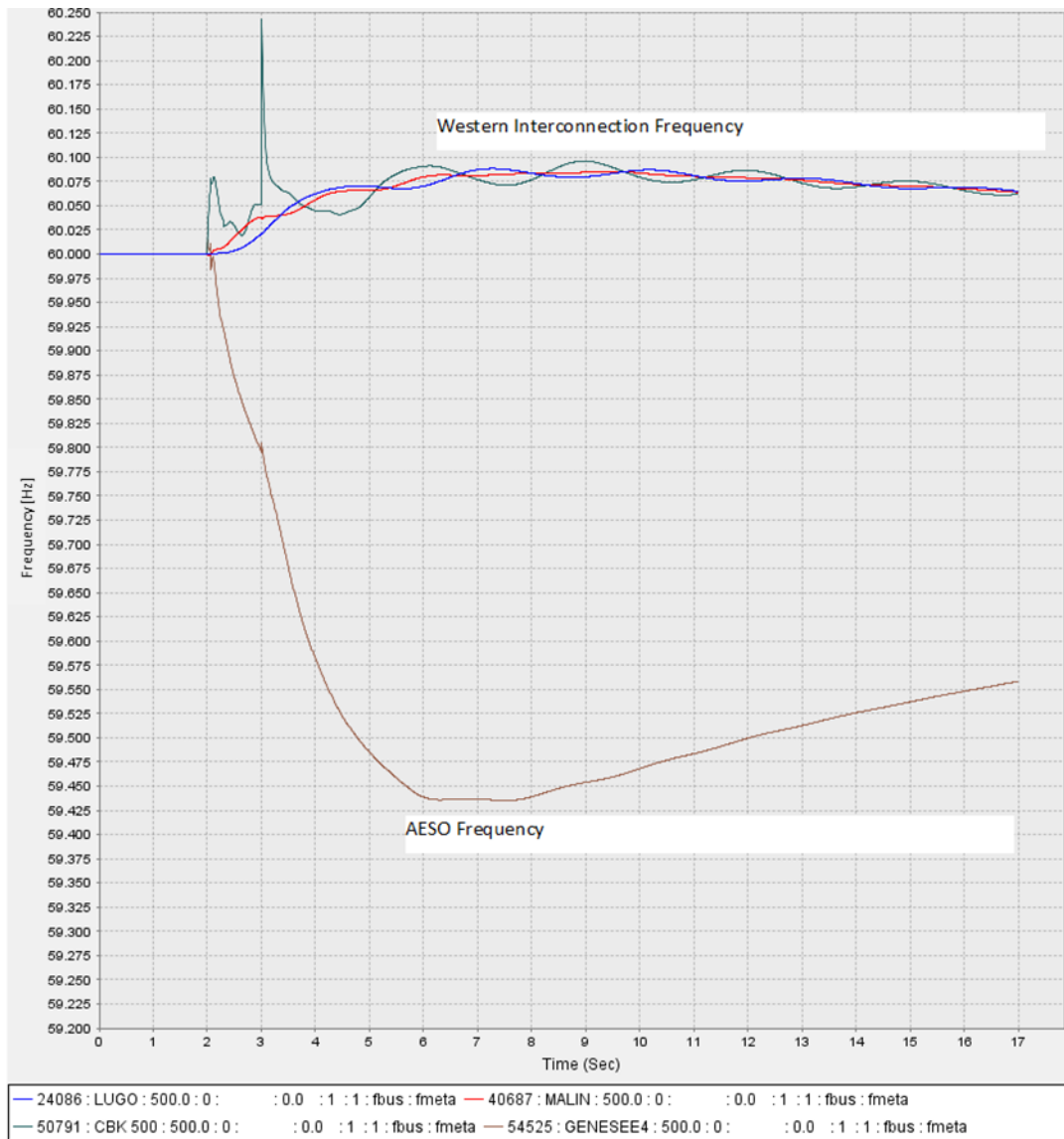

Figure C.1: Bus Frequencies for Controlled AESO Separation

[Source: Peak]



Figure C.2: Bus Voltages for Controlled AESO Separation

[Source: Peak]

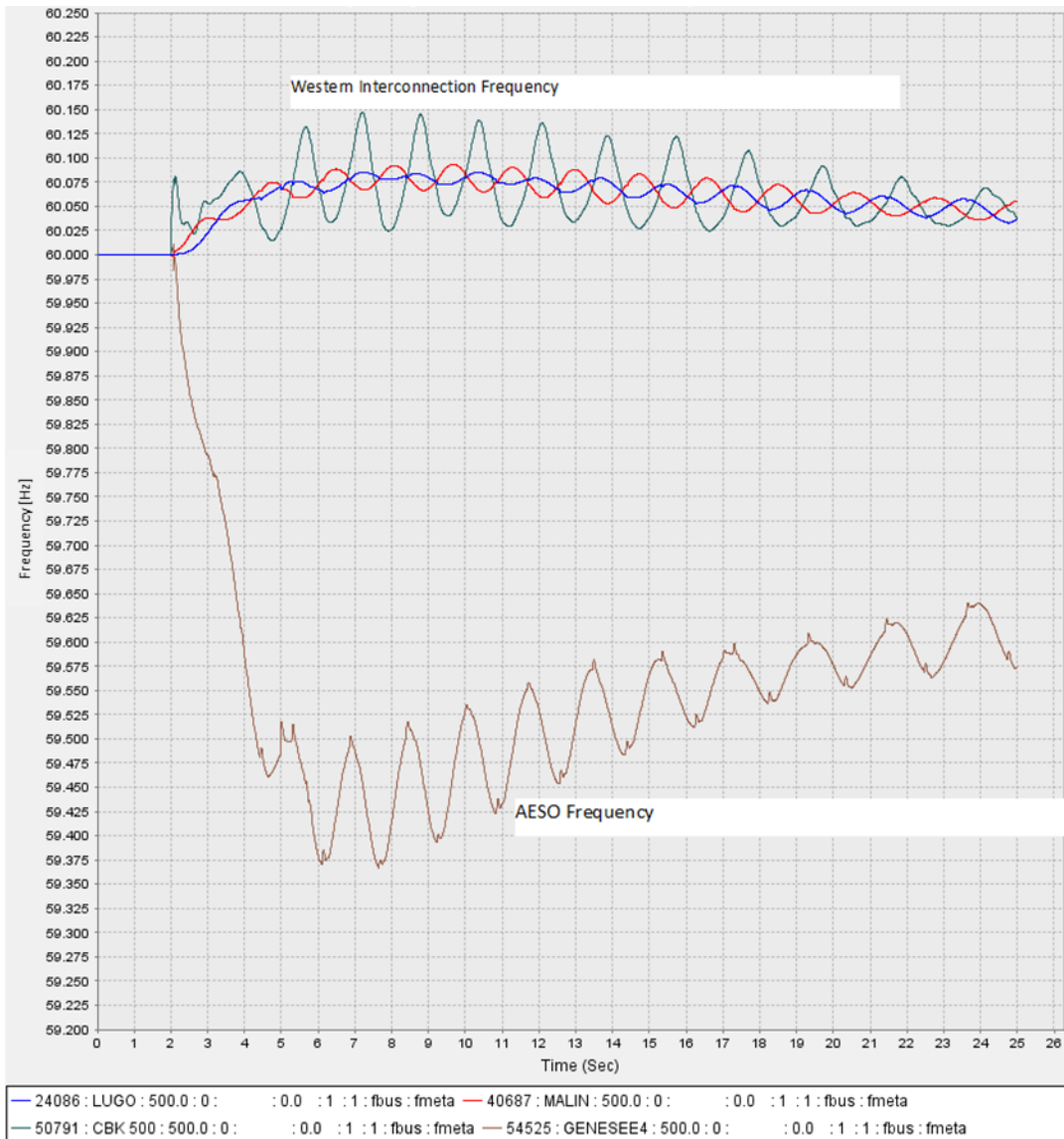

Figure C.3: Bus Frequencies for Uncontrolled AESO Separation

[Source: Peak]

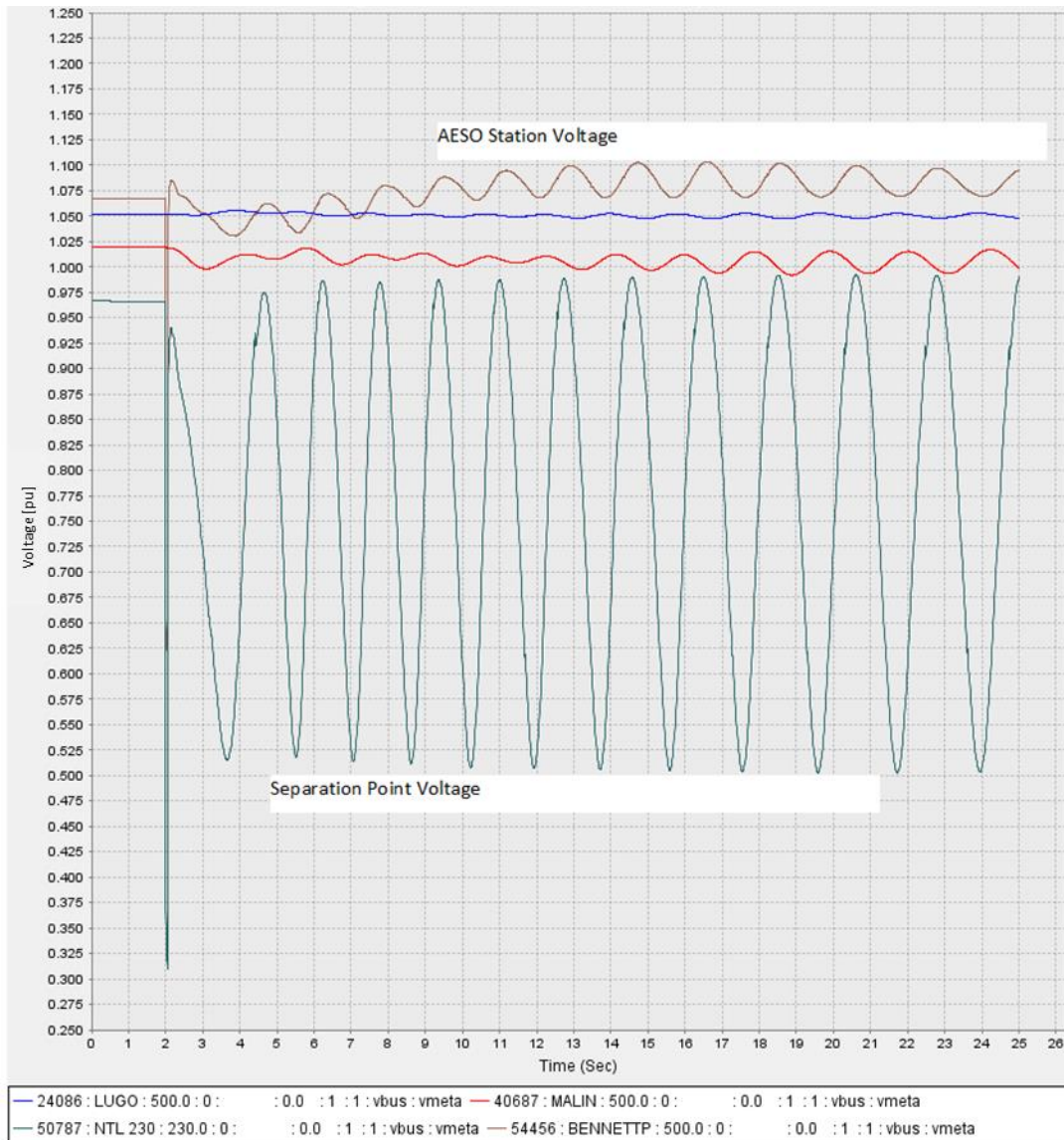

Figure C.4: Bus Voltages for Uncontrolled AESO Separation
 [Source: Peak]

Appendix D: Examples of Cascading Analysis

This section provides examples of the analysis of cascading and considerations that may be made during the analysis. These examples provide an illustration of bounded and unbounded cascading.

Example 1a: Bounded Cascading in Local Load Pocket

The system in [Figure D.1](#) consists of a local pocket of 250 MW load and 50 MW generation fed by two 230 kV lines and one 115 kV line. Power therefore flows from the BPS to the load pocket most of the time, particularly under peak conditions. The system is planned to be N-1 secure and stable under all expected operating conditions. However, consider an operating condition where one of the 230 kV lines is out indefinitely (e.g., storm, required maintenance). Loss of the other 230 kV line results in contingency analysis showing the 115 kV line loaded to 130 percent of its highest emergency thermal rating with no low voltage issues. This results in the creation of an operating plan to address the SOL exceedance and minimize the possibility of these conditions occurring.

The question arises as to whether an IROL should be established for this condition since this post-contingency condition results in an overload and high potential for cascading (since the line is overloaded to 130 percent of its highest emergency facility rating). Loss of the 230 kV line overloads the 115 kV line, and loss of the 115 kV line (e.g., due to line sag) results in the loss of the local pocket of generation and load. Upon tripping this pocket, no further risk of cascading exists and the cascading is considered bounded. The RC then determines if the amount of load lost is within reason for IROL establishment. In this case, an IROL is not established.

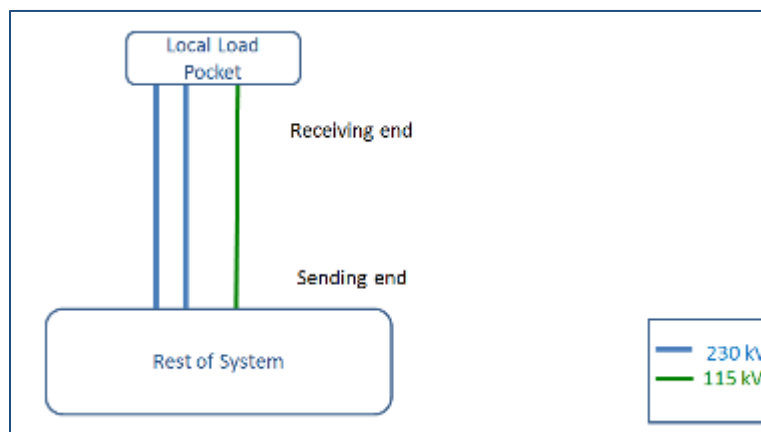

Figure D.1: Example 1a and 1b System

Example 1b: Bounded Cascading in Local Load Pocket Voltage Collapse

Now consider the same system as Example 1a; however, in this example the loss of one 230 kV line with the other 230 kV line out of service causes a divergent powerflow solution in contingency analysis. A “soft outage” on the second 230 kV line shows that as the line impedance is increased, voltages begin to fall to below 0.7 pu in the load pocket. Voltages on the sending end of the line remain near nominal (within acceptable post-contingency limits).

The post-contingency point during the “soft outage,” just before solution divergence, most likely will not show that the apparent impedance of the line relay (at the sending end) falling within the primary or secondary protection zones due to the constant power load modeling assumption. A dynamic simulation with a detailed load model is used to study the voltage collapse. The simulation shows that either the collapse⁷⁴ causes the line relay to operate, or the

⁷⁴ In the dynamic simulation, the modeling of motor loads and other load dynamics may show a significantly higher draw of current during the collapse. This may further depress system voltages and possibly result in the apparent impedance encroaching on the relay zones of protection.

load protection trips itself off and the system recovers to within facility ratings. Either result is an example of a bounded cascading event.

In this case, the instability is clearly studied and identifiable, and the analysis shows that the voltage collapse caused by the 230 kV line loss is contained to the local load pocket. The loss of load is within acceptable levels for the establishment of an IROL. Therefore, an SOL is established but an IROL is not.

Example 2: Bounded Cascading with Substation Mid-Line

The system under consideration for Example 2 is similar to that of Example 1, except that Substation A is a tap off the 115 kV line between the load pocket and the BPS. For the studied conditions, loss of both 230 kV lines results in the 115 kV #2 line loading to 130 percent of its emergency rating and no other overloads or low voltages on the system post-contingency. Cascading analysis shows that the loss of those 230 kV lines and the subsequent overload on the #2 line will result in tripping of the #2 line. The loss of that line severs the load pocket from the BPS and again the cascading is considered bounded and within acceptable limits of load loss. No IROL is established.

Similar to Example 1b, assume that the loss of the two 230 kV lines results in a divergent powerflow solution. In this case, the RC may study the instability to determine its containment by following the guidance in this document. Conversely, the RC may determine it prudent to sectionalize the load pocket and Substation A, following the first 230 kV line outage by opening the 115 kV #1 line. The load pocket is served from the 230 kV line and Substation A is served from the 115 kV #2 line, and no further contingency analysis violations show up.

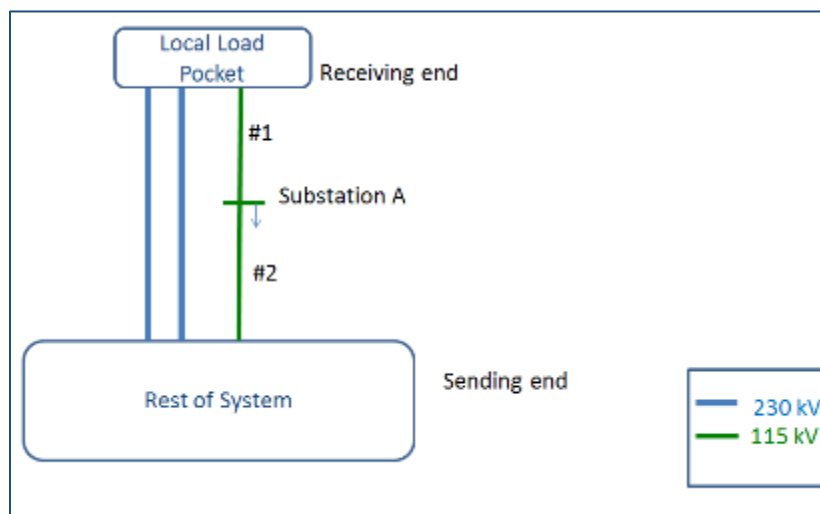

Figure D.2: Example 2 System

Example 3: Load Pocket Interactions

This example involves the test system shown in Figure D.3, which includes a local load pocket, a larger metropolitan area, and connections to the larger BPS. The local load pocket is again fed by two 230 kV lines and one 115 kV line. The larger metropolitan area is connected to the BPS through multiple 230 kV lines and also connected to a substation feeding the local load pocket through a 115 kV line.

Now consider an operating condition where loss of the two 230 kV lines will result in the 115 kV #1 line loading to 130 percent of its highest emergency rating and the 230/115 kV transformer loading to 125 percent of its highest emergency rating. No other overloads or low voltages exist on the system.

Cascading analysis that trips the highest overloaded element first would result in first tripping the 115 kV line. This would result in losing the local load pocket generation and load, and the remaining system returns to acceptable

operating conditions. The cascading is considered bounded (as shown in the previous examples). No IROL is established for this condition.

Now consider the situation where the transformer is removed before the 115 kV #1 line as part of the cascading analysis. The local load pocket is then served from the 115 kV #1 and #2 lines. This subsequently causes some thermal overloaded and low voltages in the metropolitan area. Subsequent cascading analysis shows that the large metropolitan area experiences voltage collapse from the cascading, and no clear boundary can be determined. This is considered system instability that resulted from the cascading, and the unbounded cascading is not considered acceptable. Therefore, an IROL should be established in this situation to protect against the unbounded cascading that ends in system instability.

If the large metropolitan area did have a clear and quantifiable boundary of instability and analysis showed clear protection operation for the boundary lines, then the determination of an IROL for this instability would be based on the size of load lost in the both the metropolitan area and local load pocket. If the load lost exceeded the allowable limits established in the SOL Methodology, then an IROL would be established.

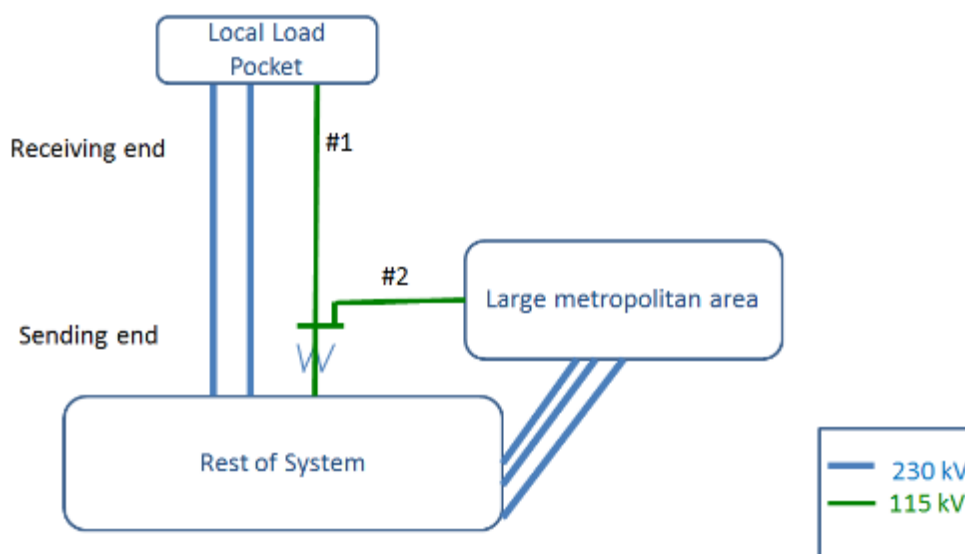

Figure D.3: Example 3 System

Example 4: Bounded Cascading Sequence of Events

This example uses an actual system with a severe contingency applied to a stressed operating condition. **Figure D.4** shows the sequence of cascading events that would occur (assuming sequential tripping of the highest overloaded element), read from left-to-right and top-to-bottom. The initiating contingency is loss of a substation (top left), resulting in a number of elements removed from service and subsequent depressed voltage. The sequence of cascading then causes this low voltage pocket to continue to get worse; however, voltage instability does not occur in the simulation. However, after five cascading events following the loss of the substation, the load pocket is tripped off-line due to the last remaining overloaded transmission line serving that pocket tripping. Following that cascading event, voltage returns to near nominal and all flows are within expected limits.

This is a clear example of bounded cascading that results in a quantifiable amount of load loss. Some RCs may use a threshold for load loss established in the SOL Methodology and assessed by the RC using risk analysis to determine if an IROL should be established.

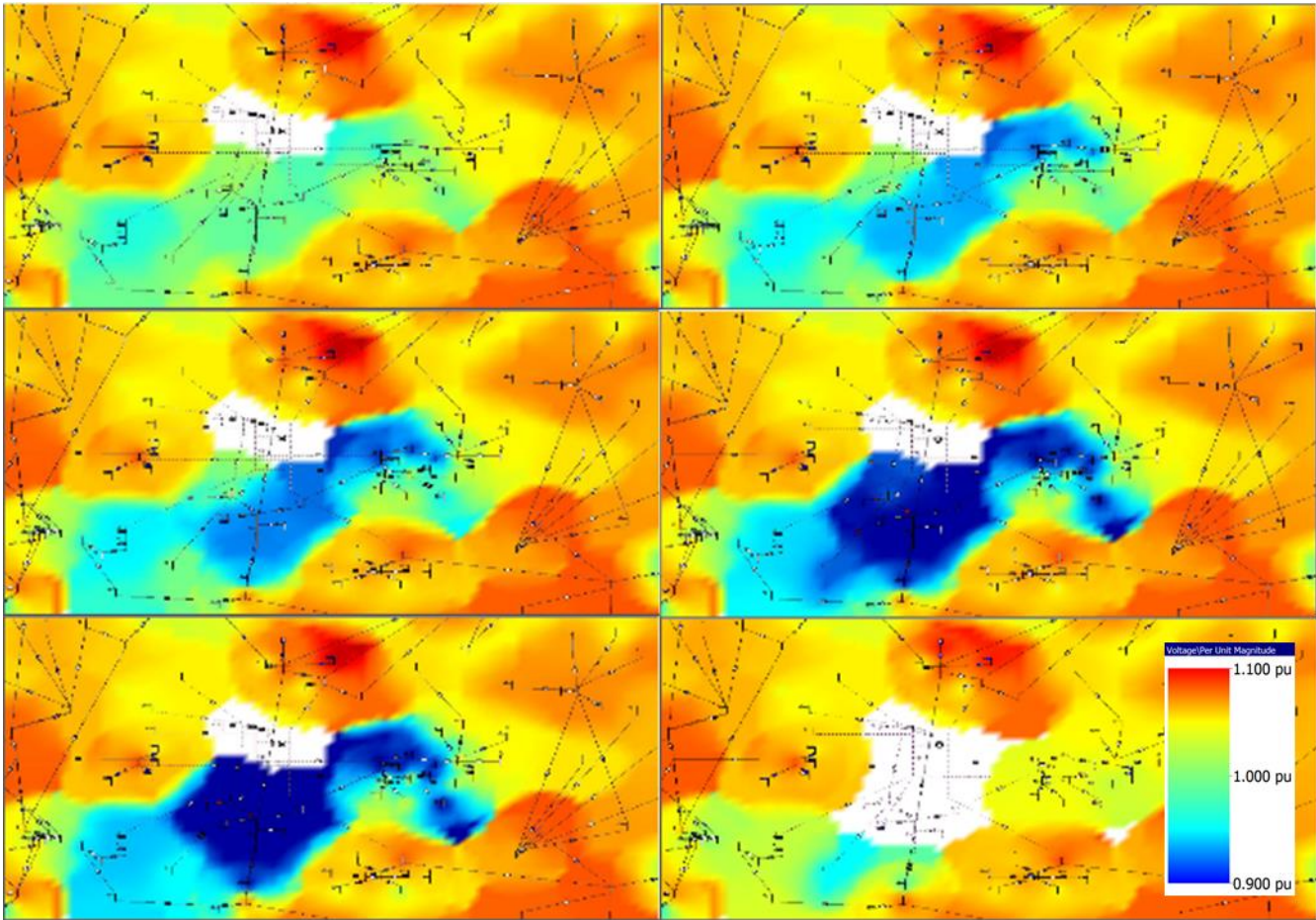

Figure D.4: Example 4 Bounded Cascading Sequence [Source: PJM]

Example 5: Unbounded Cascading Sequence of Events

This example also uses an actual system with a severe contingency applied to a stressed operating condition. **Figure D.5** shows the sequence of cascading events that would occur (assuming sequential tripping of the highest overloaded element), read from left-to-right and top-to-bottom. The initiating contingency has minimal impact to the area, with no voltage issues and a couple of thermal overloads. The sequence of cascading continues to three cascading events (bottom left), and the subsequent outage results in a diverged powerflow solution.

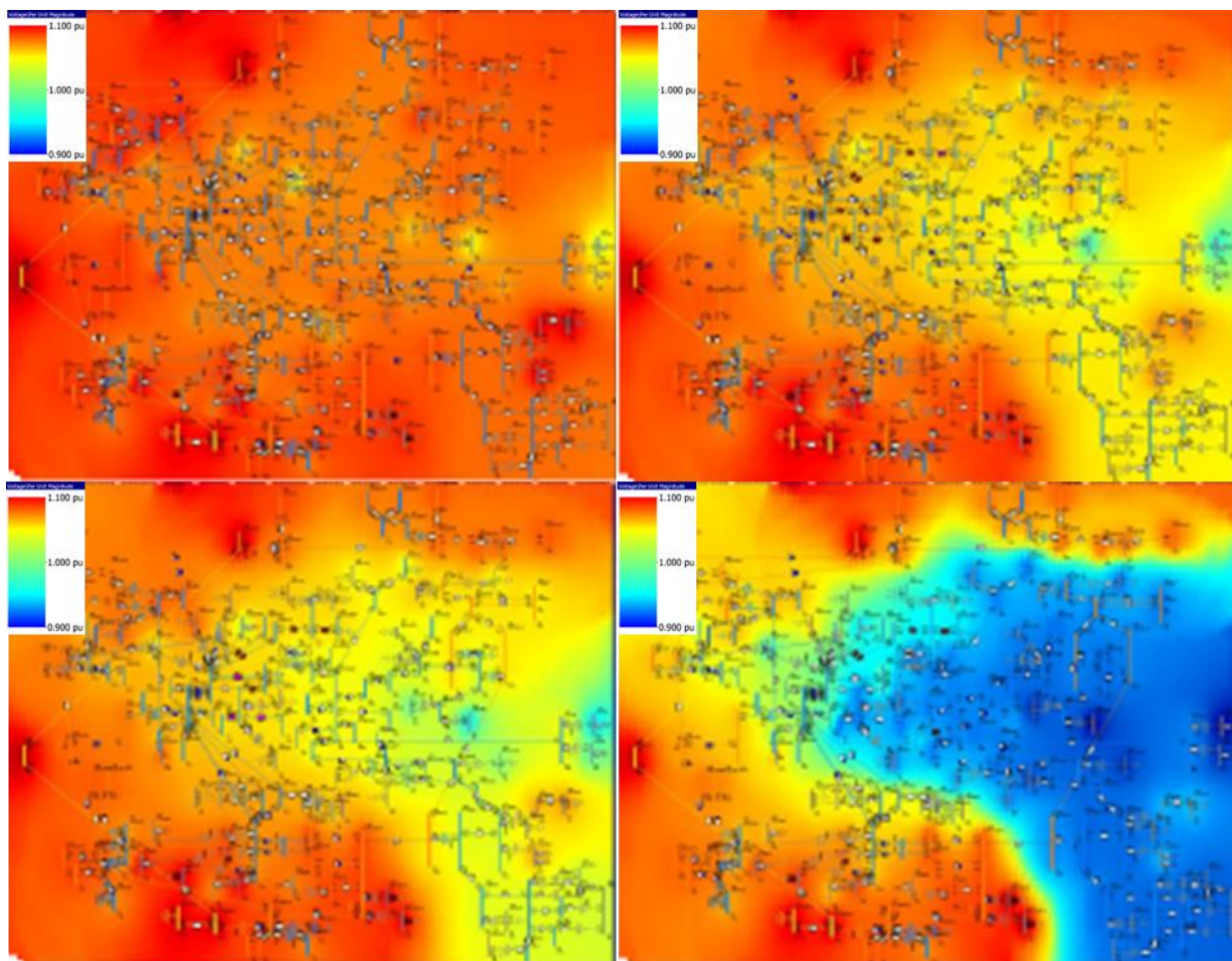

Figure D.5: Example 5 Cascading Sequence up to Collapse [Source: PJM]

To analyze the divergent solution, the “soft outage” approach is used. The line outage that causes the impending voltage collapse is taken by increasing the line impedance towards infinity until a collapsed (divergent) case is attained. **Figure D.6** shows the sequence of soft outages as the impedance is increased on the contingent line. It is clear that the voltage falls drastically low (< 0.7 pu) across a wide area of buses. As the impedance is increased, that zone of impact increases to widen the region of collapsed buses. At the point of instability, the large load pocket has actually severed the adjacent parts of the system from each other.

This situation was deemed unbounded cascading that led to system instability due to the wide breadth of buses affected by the cascading events as well as the inability to clearly draw a boundary around the collapsed system. With many remaining transmission lines connecting the load pocket to the rest of the BPS, there is too much uncertainty as to how exactly the collapse would transpire and whether or not it would expand to a wider area. The result is a declaration of system instability and the establishment of an IROL.

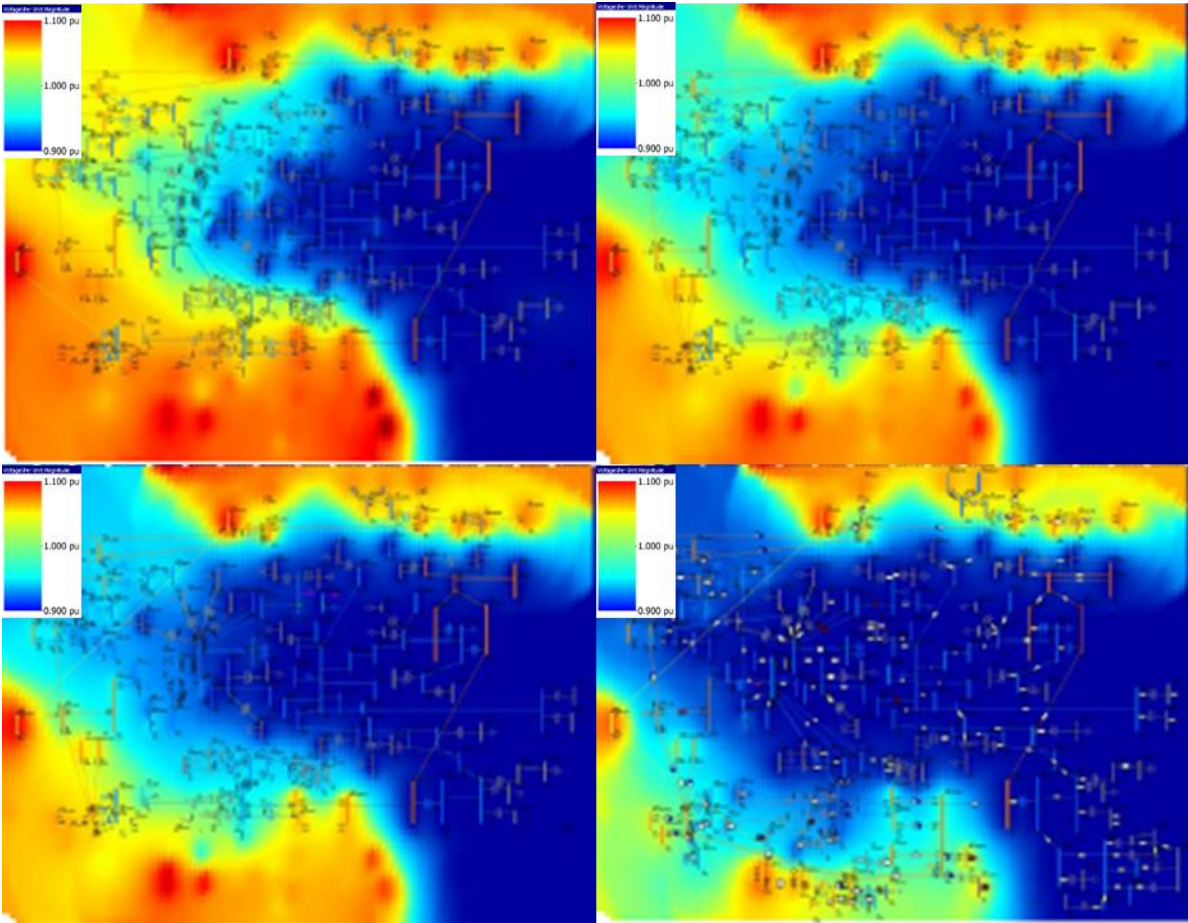

Figure D.6: Example 5 Soft Outage Confirmation of System Instability [Source: PJM]

Appendix E: Using Real-Time Stability Tools for IROLs

The use of near real-time stability tools for establishing and/or updating IROLs has significant benefits as well as notable challenges. Often, this depends on the type of instability being studied and the degree of complexity that instability introduces. This section describes important considerations—benefits and challenges—of implementing

Benefits of Real-Time Tools for RTAs

The NERC Reliability Standards require each TOP and RC to ensure that a RTA is performed at least once every 30 minutes and that associated operating plan(s) are initiated to mitigate a potential or existing SOL exceedance identified as part of its RTA. Periodic RTA are used by TOPs and RCs to maintain situational awareness of the BPS and to measure performance against SOLs. There are many methods, information sources, tools, and applications available to complete an RTA. Real-time tools include state estimation, topology processor, RTCA, voltage stability analysis tools, transient stability analysis tools, oscillation detection tools, and generation and load (MW and MVAR) distribution factor analyses. Such tools are capable of analyzing the impact on system reliability resulting from changes in system load, system voltages, dynamic real and reactive power and reserves, system topology, PSS or AVR status, scheduled interchange, parallel flows, etc. on Reliable Operation.

Providing a system operator with a suite of real-time tools and supporting operating plans allows the system operator to analyze the impact of changing system conditions, implement effective strategies to mitigate SOL exceedances, and ensure that SOL exceedances do not result in system instability, uncontrolled separation, or cascading. When these tools work in concert with security constrained economic dispatch, cascading analysis, intelligent situational awareness tools, etc., the operator has the advantage of responding to system events by using a dynamic set of tools.

Entities that rely on OPAs (off-line studies) to update IROL limits prior to real-time operation generally operate to more conservative limits by applying more conservative study assumptions and operating limit margin that reflect the potential impact of varying operating scenarios their operator tools are unable to model in real-time. In these situations, RCs may take a conservative approach by establishing additional IROLs that otherwise may not be required if real-time tools and associated operating plans are in place. Real-time tools provide the operator with flexibility to determine the BPS operating state with respect to SOLs more effectively as well as enable more effective cascading analysis and voltage stability assessments. While potential IROLs still need to be explored and established in the OPAs or other time horizons, real-time tools enable effective updates to these limits to utilize the system capacity to the best extent possible based on actual system conditions met in real-time.

Potential Issues with Real-Time Transient Stability Analysis

In the operations arena, the majority of TOPs and RCs use tools such as contingency analysis to perform steady-state assessments of near real-time conditions on a continual basis. This allows for SOL and IROL exceedances to be identified in real-time. However, the implementation of near real-time transient and small signal stability tools is much more limited compared to near real-time powerflow tools. Some of the limitations and potential issues to consider with implementing these tools include the following:

- Some real-time stability analyses have computational limitations that may require that a subset of contingencies be selected for evaluation in order to complete a timely assessment of the impending system conditions. Techniques have been developed and implemented by entities that extend these limitations, such as early simulation termination logic based on the swing margin threshold and/or peak to peak angle margin threshold that shortens simulation time for stable contingencies while extending simulation time for contingencies displaying initial unsatisfactory damping.
- Real-time tools often use simplifying assumptions that do not determine all types of potential stability limits. For example, near real-time stability tools generally use simplified load models that are not as detailed or inclusive of induction motor load behavior as compared with the off-line study tools.

- Maintaining an updated powerflow and associated dynamics data file for all real-time operating conditions requires automation and has significant challenges with its implementation. For example, the dispatch and responsiveness of generators can alter the simulation results, particularly for wide-area system instability events. Gathering near real-time parameter values for generators and other control devices, particularly those outside the RC/TOP footprint, are a challenge.
- Initialization issues for areas outside the RC/TOP footprint may lead to the inability to perform the stability simulations. For this reason, external areas are often equivalenced. There are proven tools available to the industry that are used to build representative external dynamic model equivalents; however, many engineer man-hours with appropriate subject matter expertise are required.
- Generation and load modeling is becoming increasingly complex. Acquiring data and building models to represent inverter-based resources, especially distributed energy resources (DER), are a challenge even in the Long-Term Planning horizon. These complexities result in challenges in managing near real-time assessments that are running continuously.
- The execution of dynamic simulation studies is inherently complex, involving the solving of a large number of differential equations every time step (typically every $\frac{1}{2}$ cycle). It requires SME support, either on-site or on-call, on a 24x7 basis.
- The determination of whether an instability is more localized or whether it is a system instability requires significant engineering judgment and expertise. This type of analysis is not automated in any of the stability tools used in planning or operations.

For the reasons listed above, RCs and TOPs may determine transient or small signal stability based SOLs and IROLs in the planning horizon for use in the operations horizon. Limits may be updated as real-time approaches, and the operating conditions around these IROLs are closely monitored in real-time. Some example of these types of SOLs or IROLs include the following:

- Stability limits for lines at plants that do not have redundant pilot protection and may be subject to Zone 2 protection operation. The limit may be the amount of generation that can be dispatched at that plant to maintain stability for the worst contingency. This type of analysis is not typically implemented in near real-time assessments due to the complications of managing the real-time status of pilot schemes and subsequent changes to the stability screening to include appropriate Zone 2 fault(s).
- Stability limits associated with complex load dynamics (e.g., fault induced delayed voltage recovery (FIDVR)). Some stability limits may be based on phenomenon that requires detailed stability studies and sensitivity analysis to fully understand and establish limits. These sensitivities (e.g., generation dispatch, demand level, transmission topology) require time and engineering judgment to identify the key drivers for the instability and the best indicator for establishing an IROL.
- Stability limits where the contingency or affected area is external to the area being studied. For example, a large loss of generation in one part of the system could cause uncontrolled separation or voltage or transient instability in another part of the system. Similarly, a contingency in the studied area could have a severe impact on neighboring areas. To fully understand and coordinate these limits with neighbors requires time and engineering judgment, often making these conditions unmanageable in near real-time assessments. Ultimately, it is the responsibility of the RC to coordinate with a wide-area view, which may be done using either real-time tools or off-line studies. The benefit of real-time tools is that many of the unknown variables in off-line studies are known in real-time, leading to more updated results.

Appendix F: M-8 Reporting by Reliability Coordinators

The MEITF reviewed how each RC reports IROLs for the M-8 IROL exceedance metric (quarterly NERC ALR 3-5 IROL exceedance report). **Table F.1** shows the reporting methods for each RC as documented at the time of publication.

The MEITF proposed modifications to the M-8 reporting metrics to address the disparate reporting techniques and recommends that RCs report the Pre-Determined IROL (without margin) that is either pre-determined one or more days prior to real-time or updated in near real-time (based on the RC operating practices).

Reliability Coordinator	Pre-Determined IROL (with Margin)	Pre-Determined IROL (No Margin)	Real-Time IROL (with Margin)	Real-Time IROL (No Margin)	After-the-Fact IROL
ERCOT				✓	
FRCC					✓
HQ	✓				
ISO-NE					✓
MISO ⁷⁵	✓			✓	
NB	✓				
NYISO	✓				
IESO	✓				
Peak		✓		✓	
PJM				✓	
SaskPower	✓				
Southern Co.		✓		✓	
SPP		✓			
TVA					✓
VACAR South	✓		✓		

⁷⁵ MISO reports Actual IROL exceedances as well as Pre-Determined IROL (with margin) exceedances, depending on the type of IROL.

Appendix G: List of Acronyms

Table G.1: List of Acronyms	
Acronym	Term
ATC	Available Transfer Capability
AVR	Automatic Voltage Regulator
BA	Balancing Authority
BPS	Bulk Power System
BES	Bulk Electric System
DAL	Drastic Action Limit
EMT	Electromagnetic Transient
FACTS	Flexible AC Transmission System
FERC	Federal Energy Regulatory Commission
GO	Generator Owner
GOP	Generator Operator
HP	High Pressure
HVDC	High Voltage Direct Current
IGE	Induction Generator Effect
IROL	Interconnection Reliability Operating Limit
LODF	Line Outage Distribution Factor
LP	Low Pressure
LTE	Long-Term Emergency Rating
MEITF	Methods for Establishing IROls Task Force
NERC	North American Electric Reliability Corporation
OEL	Over Excitation Limiter
OLTC/ULTC	On-Load Tap Changer/Under-Load Tap Changer
OOS	Out of Step
OPA	Operational Planning Analysis
PC	Planning Coordinator
PTDF	Power Transfer Distribution Factor

Table G.1: List of Acronyms	
Acronym	Term
P-V	Active Power-Voltage Analysis
RAS	Remedial Action Scheme
RC	Reliability Coordinator
RTA	Real-Time Analysis
SAR	Standard Authorization Request
SCR	Short Circuit Ratio
SDT	Standard Drafting Team
SOL	System Operating Limit
SSA	Small Signal Analysis
SSCI	Subsynchronous Control Interaction
SSI	Small Signal Instability
STATCOM	Static Compensator
STE	Short-Term Emergency Rating
SVC	Static Var Compensator
TA	Torsional Amplification
TI	Torsional Interaction
TLR	Transmission Loading Relief
TO	Transmission Owner
TOP	Transmission Operator
TP	Transmission Planner
UEL	Under Excitation Limiter
UFLS	Underfrequency Load Shedding
UVLS	Undervoltage Load Shedding
V-Q	Voltage-Reactive Power Analysis

Appendix H: Contributors

NERC gratefully acknowledges the contributions of the MEITF members and contributors. In addition, many of the topics and concepts addressed throughout this guideline were introduced by the IEEE/CIGRE Joint Task Force on Definition and Classification of Power System Stability. NERC gratefully acknowledges the joint task force for introducing the concepts and serving as a cornerstone for which practical application of the concepts can be developed and applied.

Table H.1: Contributors

Name	Entity	Status
Andrew Arana	Florida Power & Light (FPL)	Member
Wayne Guttormson	SaskPower	Member
Vic Howell	Peak Reliability	Member
Gary Keenan	Northwest Power Pool (NWPP)	Member
Dean LaForest	Independent System Operator-New England (ISO-NE)	Member
Charles-Eric Langlois	Hydro Quebec (HQ)	Member
Durgesh Manjure	Midcontinent Independent System Operator (MISO)	Member
Jonathan Prater	Tennessee Valley Authority (TVA)	Member
Nathan Schweighart	Tennessee Valley Authority (TVA)	Member
Hari Singh	Xcel Energy	Member
David Souder	PJM Interconnection	Member
John Stephens	City Utilities of Springfield, MO	Member
Lee Taylor	Southern Company	Member
Dan Woodfin	Electric Reliability Council of Texas (ERCOT)	Member
Emanuel Bernabeu	PJM Interconnection	Contributor
Xinghao Fang	Independent System Operator-New England (ISO-NE)	Contributor
Hamody Hindi	Bonneville Power Administration (BPA)	Contributor
Grant Marchewca	ReliabilityFirst (RF)	Contributor
Don McInnis	Peak Reliability	Contributor
Sasa Mizdrak	Independent Electricity System Operator (IESO)	Contributor
John Simonelli	Independent System Operator-New England (ISO-NE)	Contributor
Kyle Thomas	Dominion Virginia Power	Contributor
Carl Turner	Florida Municipal Power Agency (FMPPA)	Contributor
Brad Woods	Texas Reliability Entity	Contributor
Ryan Quint (Coordinator)	North American Electric Reliability Corporation	NERC Staff
John Skeath	North American Electric Reliability Corporation	NERC Staff
Ganesh Velumylyum	North American Electric Reliability Corporation	NERC Staff