

NERC

NORTH AMERICAN ELECTRIC
RELIABILITY CORPORATION

Reliability Guideline

Primary Frequency Control

September 2023

RELIABILITY | RESILIENCE | SECURITY



**3353 Peachtree Road NE
Suite 600, North Tower
Atlanta, GA 30326
404-446-2560 | www.nerc.com**

Table of Contents

Preface	iii
Preamble	iv
Executive Summary.....	v
Chapter 1: Background.....	vi
Purpose.....	vi
Applicability	vi
Chapter 2: Frequency Control – Fundamentals	1
Arresting Period.....	1
Recovery Period.....	2
Post Recovery Period.....	2
Chapter 3: Primary Frequency Control	3
Allocation and Distribution of Frequency Responsive Reserve for Sustained Primary Frequency Response	3
Coordination between a Resource’s Governors and Output Controls	4
Ability of Natural Gas Turbines to Sustain Primary Frequency Response Following Large Loss-of-Generation Events	7
Primary Frequency Response from Inverter-Based Resources	8
Fast Frequency Controls on Electronically Coupled Wind Generation and Sustained Primary Frequency Response	9
Chapter 4: Governor Deadband and Governor Droop Settings.....	11
Eastern Interconnection	12
ERCOT Interconnection	13
Western Interconnection	13
Quebec Interconnection.....	14
Chapter 5: Performance Assessment.....	15
Appendix A: Typical Unit Response to Low and High Frequency Events by Unit Type.....	16
Appendix B: Sample Validation, Response Type Classification, and Droop/Deadband Verification	23
Sample Validation.....	23
Response Type Classification.....	23
Governor Deadband and Droop Verification	24
Appendix C: Definitions and Terminology	25
Appendix D: Related Documents	27
Contributors	28
Guideline Information and Revision History.....	29
Metrics	30

Preface

Electricity is a key component of the fabric of modern society and the Electric Reliability Organization (ERO) Enterprise serves to strengthen that fabric. The vision for the ERO Enterprise, which is comprised of the NERC and the six Regional Entities, is a highly reliable, resilient, and secure North American bulk power system (BPS). Our mission is to assure the effective and efficient reduction of risks to the reliability and security of the grid.

Reliability | Resilience | Security
Because nearly 400 million citizens in North America are counting on us

The North American BPS is made up of six Regional Entities as shown on the map and in the corresponding table below. The multicolored area denotes overlap as some load-serving entities participate in one Regional Entity while associated Transmission Owners/Operators participate in another.

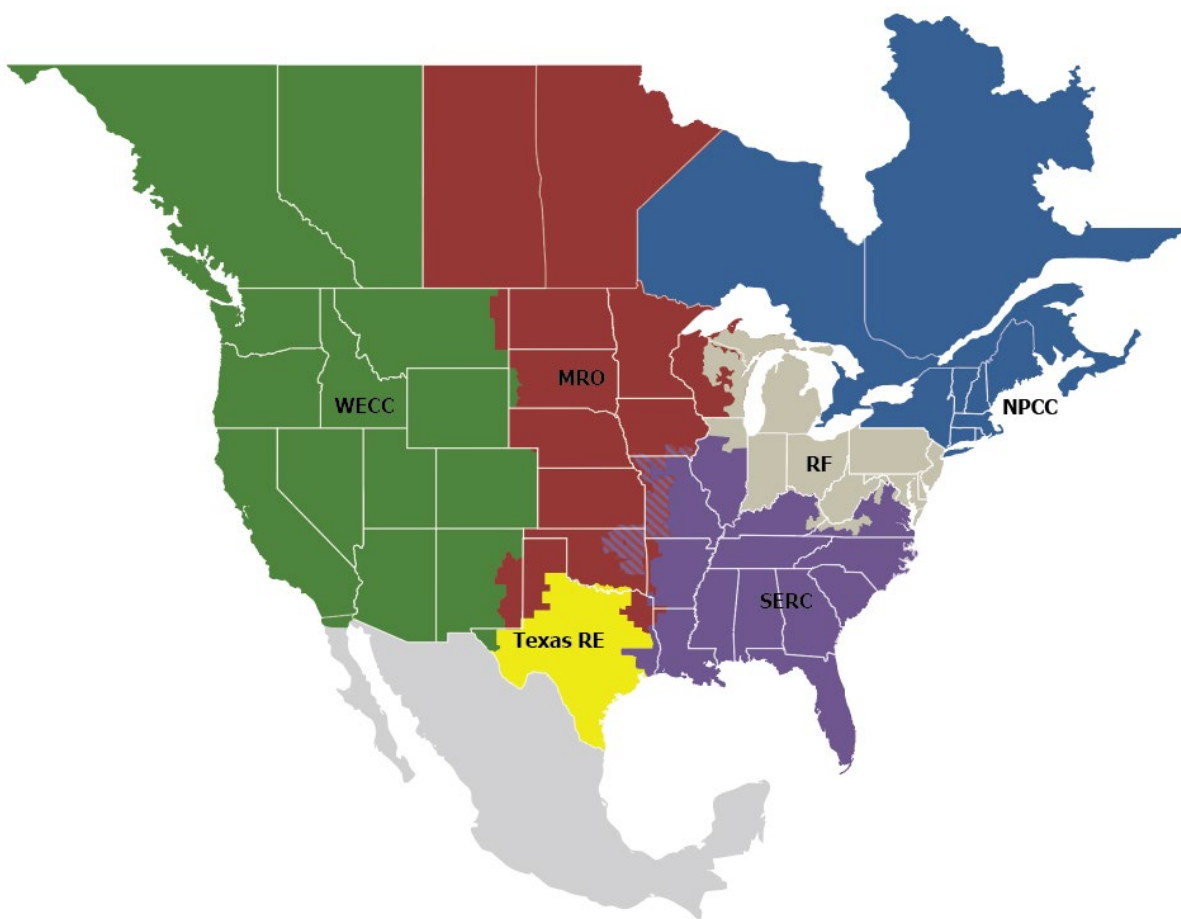

MRO	Midwest Reliability Organization
NPCC	Northeast Power Coordinating Council
RF	ReliabilityFirst
SERC	SERC Reliability Corporation
Texas RE	Texas Reliability Entity
WECC	WECC

Preamble

The NERC Reliability and Security Technical Committee (RSTC), through its subcommittees and working groups, develops and triennially reviews reliability guidelines in accordance with the procedures set forth in the RSTC Charter. Reliability guidelines include the collective experience, expertise, and judgment of the industry on matters that impact BPS operations, planning, and security. Reliability guidelines provide key practices, guidance, and information on specific issues critical to promote and maintain a highly reliable and secure BPS.

Each entity registered in the NERC compliance registry is responsible and accountable for maintaining reliability and compliance with applicable mandatory Reliability Standards. Reliability guidelines are not binding norms or parameters nor are they Reliability Standards; however, NERC encourages entities to review, validate, adjust, and/or develop a program with the practices set forth in this guideline. Entities should review this guideline in detail and in conjunction with evaluations of their internal processes and procedures; these reviews could highlight that appropriate changes are needed, and these changes should be done with consideration of system design, configuration, and business practices.

Executive Summary

This reliability guideline provides recommendations to the industry for frequency control, covering governor deadband and governor droop settings that can enable generating resources (synchronous, inverter-based, and other technologies) to provide needed primary frequency response (PFR) to the Interconnection.

NERC Regional Reliability Standard BAL-001-TRE-1 Primary Frequency Response in the ERCOT area establishes required governor settings for generating resources operating in the Texas Interconnection. Similarly, WECC has a regional criterion (PRC-001-WECC-CRT-2.1) that establishes a range of acceptable governor droop settings for generators operating in their footprint.

This guideline does not create binding norms, does not establish mandatory Reliability Standards, and does not create parameters by which compliance with Reliability Standards are monitored or enforced. In addition, this reliability guideline is not intended to take precedence over any regional procedure.

Chapter 1: Background

Purpose

This Reliability Guideline outlines a coordinated operations strategy for resources to stabilize system frequency when frequency deviates due to a grid event. It is designed to keep frequency within allowable limits while maintaining acceptable frequency control.

Applicability

This reliability guideline is intended to assist Balancing Authorities (BAs), Generator Operators (GOPs), Generator Owners (GOs), Transmission Operators (TOPs), and Transmission Owners (TOs) in understanding the fundamentals of frequency control, the recommended governor deadband and governor droop settings (so as to provide more effective frequency response during major grid events), and the techniques of measuring frequency response at a resource level. It is offered as information to other functional model entities. It outlines a coordinated operations strategy to restore system frequency after frequency has deviated due to a BES disturbance.

The primary focus of this guideline is the PFR provided by generating resources during loss of generation scenarios. Other forms of resources providing frequency response should have similar response characteristics described herein for governors.

Chapter 2: Frequency Control – Fundamentals

The instantaneous balance between generation and load is directly reflected in an interconnected electric power system’s frequency. Reliable power system operation depends on controlling frequency within predetermined boundaries above and below a nominal value. In North America, this value is 60 cycles per second (or 60 Hertz (Hz)). These concepts unambiguously apply to other Interconnections with different nominal frequencies.

BAs are responsible to dispatch generation and manage their area control error (ACE) in a manner that maintains frequency at the scheduled value using automatic generation control (AGC) on a continuous basis. NERC BAL standards establish the frequency control performance requirements for BAs.

Resilient interconnection frequency response to a sudden loss of generation or load depends upon the coordinated interplay of inertia, load damping, and defined control actions.

Figure 2.1 shows a simplified illustration of frequency and power trends that would be seen in a properly functioning power system in response to a sudden loss of generation. The event has been segmented into three periods to aid in the discussion of frequency control actions. Frequency is managed by the combined actions of primary, secondary, and tertiary controls.

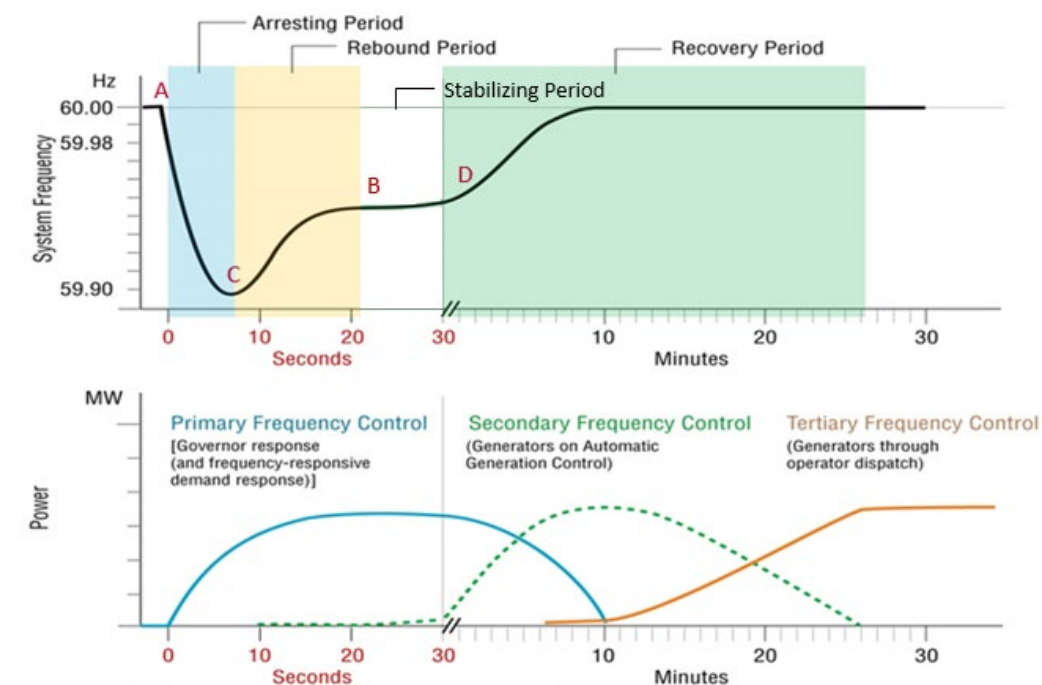

Figure 2.1: The Sequential Actions and Impacts on System Frequency of Primary, Secondary, and Tertiary Frequency Control¹

Arresting Period

As shown in the top trace (**Figure 2.1**), the “A Point” is defined as the predisturbance frequency. The time period beginning with a generation loss at T_0 and ending at the lowest frequency deviation, frequency nadir or C-Point, is labeled the “Arresting Period.” Primary control action, indicated by the solid blue line in the bottom part of the figure,

¹ Source: Eto, et al. LBNL: Use of a Frequency Response Metric to Assess the Planning and Operating Requirements for Reliable Integration of Variable Renewable Generation

starts to engage immediately once frequency falls outside the deadband. In this period, the decay of frequency must be arrested to avoid triggering under frequency load shedding (UFLS). The decline of frequency is arrested only when the combined response from load changes, load damping, demand response, and PFR responsive equals the size of generator loss. Inertia plays a critical role in determining the timing with which frequency response must be delivered to arrest the decline of frequency. The behavior of frequency after the arrest depends on the effect of primary and secondary control action and load changes.

Recovery Period

The recovery period can be divided into three sub-periods referred to as rebound, stabilizing, and recovery. In the example event referenced earlier in [Figure 2.1](#), the rebound period is defined by the sharp recovery of frequency between the C Point and T+20 seconds. Early withdrawal of primary response, as indicated by the dashed blue line, dampens the rebound and slows the recovery of frequency. The stabilizing period is defined as the window between T+20 to T+60 seconds when frequency has leveled out after the rebound period. During the stabilizing period, the collective PFR establishes a new balance between load and generation at a frequency called the settling frequency. In NERC BAL-003-1.1, the frequency defined by the period extending from T₊₂₀ to T₊₅₂ seconds is averaged and identified as the “B-Point” or the value at which frequency has been stabilized by PFR.

As mentioned above, frequency is stabilized at a value lower than the original scheduled frequency. This is an expected and necessary consequence of PFR delivered via droop control with a defined deadband. Governor droop changes resource output in proportion to the deviation of frequency once frequency has exceeded the deadband limit. PFR alone does not restore frequency to the original scheduled value primarily because governor-directed changes only occur when frequency is beyond the governor deadband.

Application of secondary control action begins when deviations of frequency and power flows are detected and continues until scheduled values have been restored. The action of automatic generation controls may be augmented or modified by manual control actions directed by system operators such as deploying contingency reserves, demand response, or establishing emergency interchange schedules. Secondary frequency control actions take place more slowly than primary frequency control actions. For example, in the case of AGC, secondary frequency control is initiated by external automated commands sent every two to six seconds. Resources typically employ a rate-of-change limit on the AGC input to the unit control system. This results in a ramp response of a resource to secondary control action.

Secondary response may require 5 to 15 minutes (and sometimes more) to complete the restoration of frequency to the scheduled value. It is therefore critical to recognize that the sustained delivery of PFR is essential for stabilizing frequency throughout the recovery period to ensure system reliability.

Post Recovery Period

In the third stage, frequency has been restored to its scheduled value, and the reserves held to provide primary and secondary frequency control are restored by tertiary control. The goal of tertiary control actions is to restore the reserves that were used to deliver PFR and secondary frequency response during the recovery period. Reserves may be restored using redispatch, commitment of resources, or establishing new interchange schedules. Restoring these reserves completes the repositioning of the power system so that it is prepared to respond to a future loss-of-generation event.

Chapter 3: Primary Frequency Control

NERC recommends that all generating resources be equipped with a functioning governor. FERC Order 842² requires any new synchronous and nonsynchronous generators to install, maintain, and operate equipment capable of providing PFR as a condition of interconnection. Primary frequency control is the first active response of resources to arrest the locally measured or sensed changes in speed/frequency. Governors are continuously active, automatic, not driven by a centralized system, and respond instantaneously to frequency deviations exceeding its governor deadband limits. Governor action is delivered proportionally on the droop curve for excursions of frequency beyond the governor deadband limits. Examples of PFR to high and low frequency events by generation type can be found in [Appendix A](#).

Allocation and Distribution of Frequency Responsive Reserve for Sustained Primary Frequency Response

The sudden loss of a generating resource will cause frequency to decline. Loss of generation events are fairly common. For this reason, each Interconnection should be designed and operated to withstand the sudden loss of a certain amount of generation without jeopardizing reliability. BAs are required to meet a frequency response obligation for their areas. Providing frequency response in such events is accomplished by maintaining frequency responsive reserve (FRR) capacity that is adequate to arrest and stabilize the decline in frequency and to reserve additional headroom that is adequate to restore frequency to its scheduled value. In a scenario where the reserved capacity of generation providing frequency response and secondary response is lower than the loss of generation, frequency would continue to decline and could potentially lead to the loss of load through the triggering of UFLS. The aggregate performance of the units supplying the reserve capacities can vary based on the number of generators and the generation mix of the fleet. Overall, the expectation is that the reserved capacity exceeds its largest expected generation loss with margin in order to account for uncertainty in the actual performance of the fleet. The NERC RSTC approved Operating Reserve Management Guideline³ provides additional details on the recommended methods to determine FRR needs.

The frequency response expected of generators should not exceed the amount they can produce before the declining frequency triggers UFLS. It is highly recommended that FRR be distributed among many generators rather than a select few in order to limit the response each unit individually needs to contribute; additionally, distributed FRR facilitates the mitigation of and recovery from wide scale events. Drawing frequency response from a large pool of geographically diverse resources makes frequency response faster, more reliable, and more effective than drawing from select isolated resources. That, in turn, helps arrest frequency earlier resulting in a higher frequency nadir and reduces the risk that some units may not provide the expected response.

The responses to generation loss from two sets of reserves are compared in Figure 3.1: Sustaining vs Nonsustaining Primary Frequency Response Effect on System Frequency [Figure 3.1](#). One (blue trace) is composed of resources that sustain PFR throughout the event in aggregate, and the other (red trace) is composed of resources that respond initially but do not sustain PFR throughout the event in aggregate. PFR is withdrawn from the set of reserves represented by the red trace before secondary frequency response is applied. In the initial phase of the event, the frequency trends for the two simulations are nearly identical because the same amount of PFR has been delivered. However, even as the nadir is reached, the effect of a lower amount of sustaining PFR of the reserves represented by the red trace can be observed; this leads to a lower apparent settling frequency. As the event progresses, the nonsustaining portion of the reserves represented by the red trace continues to reduce the PFR delivered. During the stabilizing period, frequency begins to decline again as there continues to be an imbalance of load and resource due to nonsustained PFR. This increases the risk of load being shed due to UFLS action.

² <https://www.ferc.gov/whats-new/comm-meet/2018/021518/E-2.pdf>

³

https://www.nerc.com/comm/RSTC_Reliability_Guidelines/Reliability_Guideline_Template_Operating_Reserve_Management_Version_3.pdf

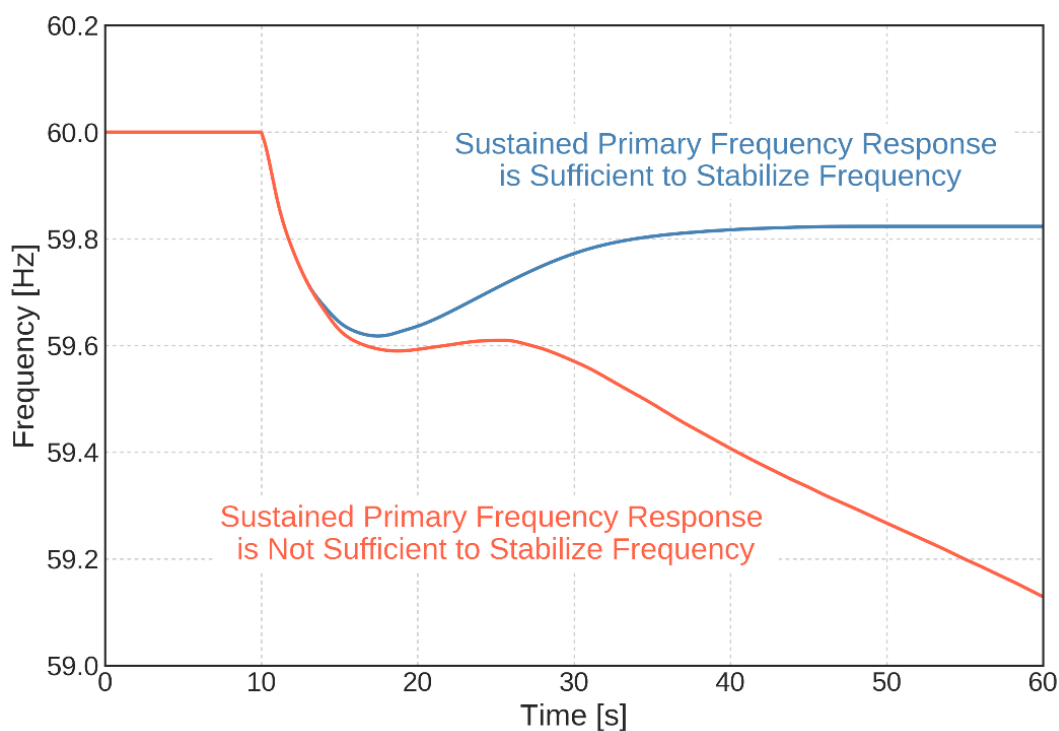

Figure 3.1: Sustaining vs Nonsustaining Primary Frequency Response Effect on System Frequency⁴

There are several reasons why PFR may not be sustained: The first is through withdrawal of PFR by the actions of plant-level or unit-level control of net resource output overriding and resetting the actions of the governor response to frequency deviations; the second is through actions stemming from inherent physical characteristics and limit actions of a generating resource. One example is the exhaust gas temperature limiter on certain types of combustion turbine/generators. These protective systems are intrinsic to the design of combustion turbine/generators and unlike plant-level controllers; these actions cannot be overridden or corrected. All generating resource types exhibit similar responses by equipment protection systems. These types of responses are also known as “squelched responses.”

These factors also reinforce the need to distribute reserves to numerous generators of different generation types in order to provide reliable sustained PFR. Each generating resource’s capability for providing a sustained response must be considered when accounting for expected PFR until it is replaced by response to secondary frequency control action.

Coordination between a Resource’s Governors and Output Controls

Modern generating resource control systems generally incorporate a form of plant or unit load control. These load control systems can be applied within the turbine control system, the plant or unit control system, or remotely from a central dispatch center. Regardless of their location or method of implementation, the design of secondary controls must be coordinated with that of the governor to ensure that PFR can be sustained.

Closed loop load control can exist at a minimum in one or possibly both load control loops based on operator selection [Figure 3.1](#). Proper coordination of control actions can be accomplished in several ways, including the following:

⁴ Source: Developed by LBNL from Undrill (2018): *Primary Frequency Response and Control of Power System Frequency*

- Use of a frequency bias in the plant level load controller would allow it to adjust individual load targets in harmony with the governor response.
- Use of a frequency bias in the turbine level load controls in conjunction with open loop load control at the plant level would allow the turbine control panel to adjust its internal load control target in harmony with the governor response.
 - In both case one and case two the plant level load controls can adjust targets in response to external input, (e.g., a revised AGC target). Plant and turbine controls must be coordinated with governor settings.
- Operation of the generating resource in pure governor control mode with manual adjustments to the speed governor target, such as analog or mechanical control systems. Some early digital controllers in use on generating resources may not be capable of operation in any form of megawatt (MW) target control.

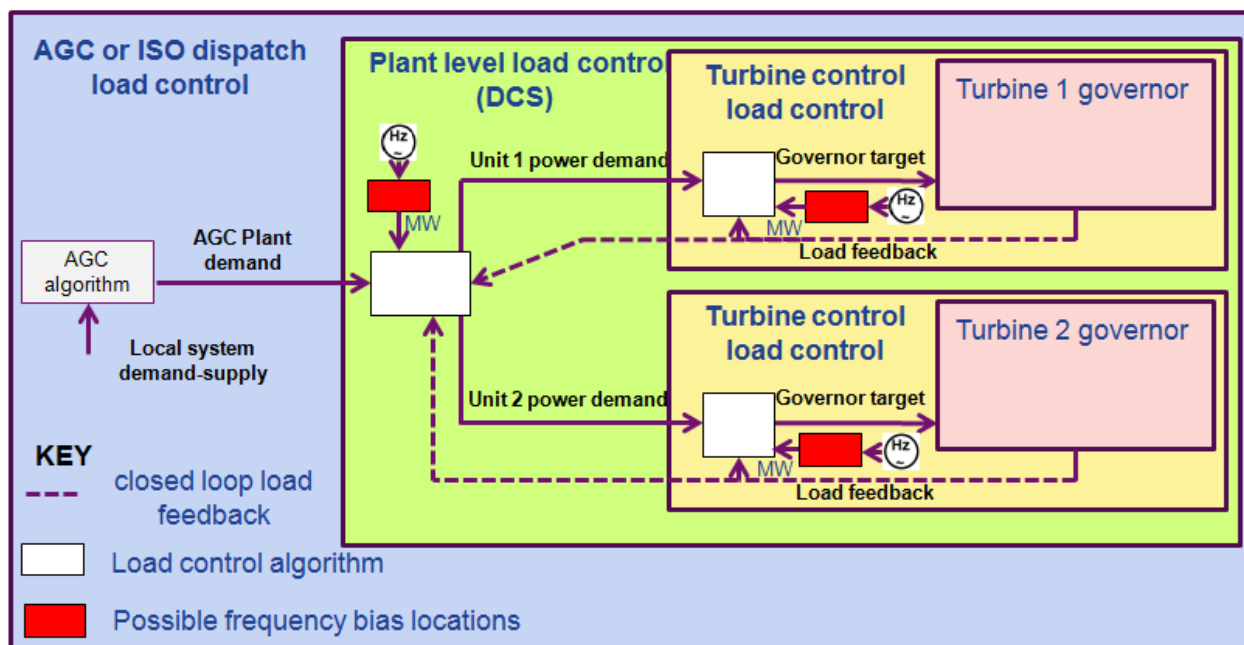

Figure 3.2: Typical High Level Generating Resource Control System

Frequency bias should be applied at all levels of closed loop MW output control for a coordinated generating resource response. See [Figure 3.3](#) and [Figure 3.4](#) for illustrations of expected frequency response from a generating resource that is properly coordinated to provide sustained PFR following loss of generation or loss of load when at steady output, ramping up, or ramping down.

Tuesday, March 03, 2015

5% Droop with +/-0.036 Hz Deadband

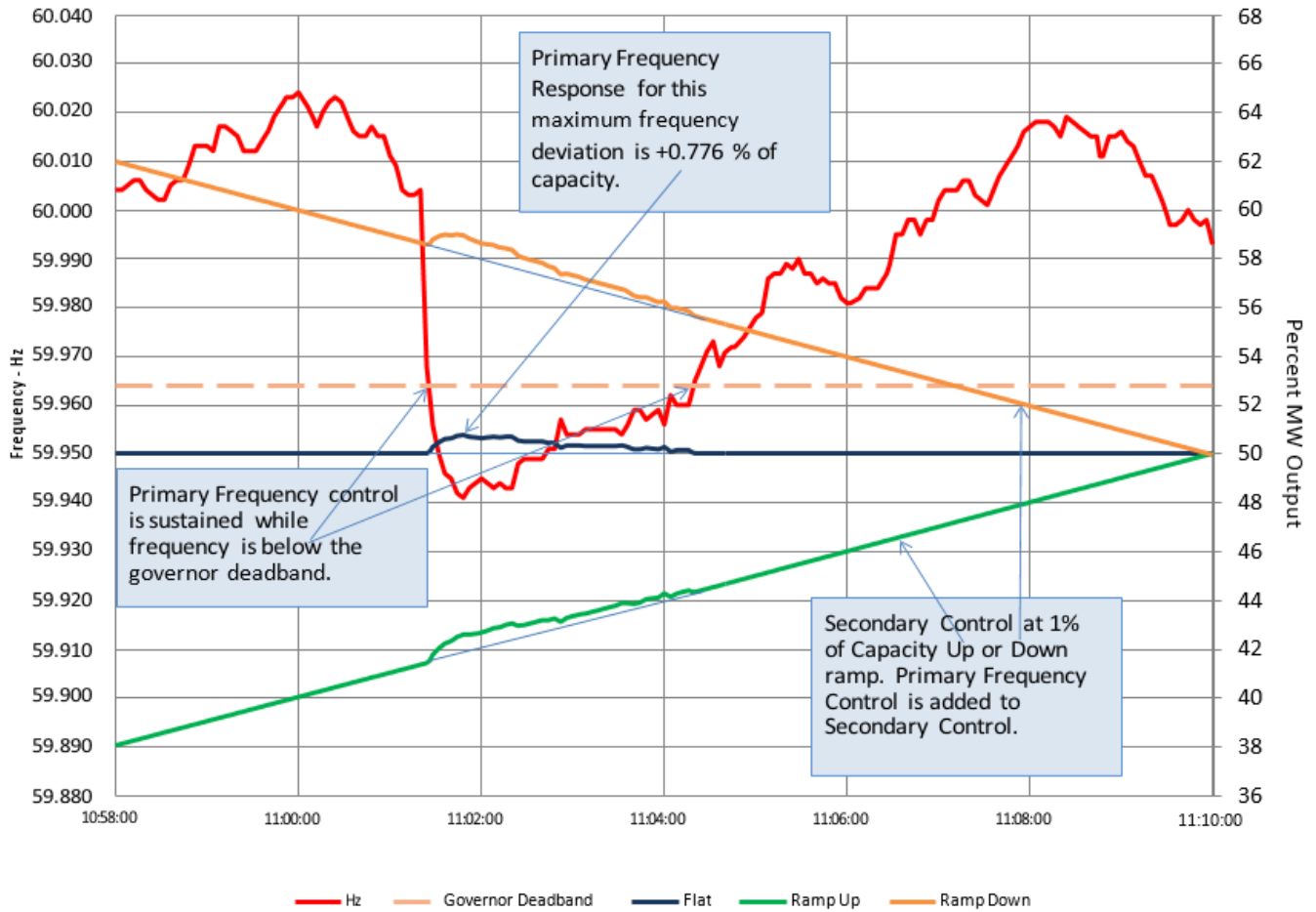

Figure 3.3: Example of Properly Coordinated Primary Frequency Control while Ramping MW Up or Down via Local or Remote Control or While Operating at a Fixed MW Output (Deadband)

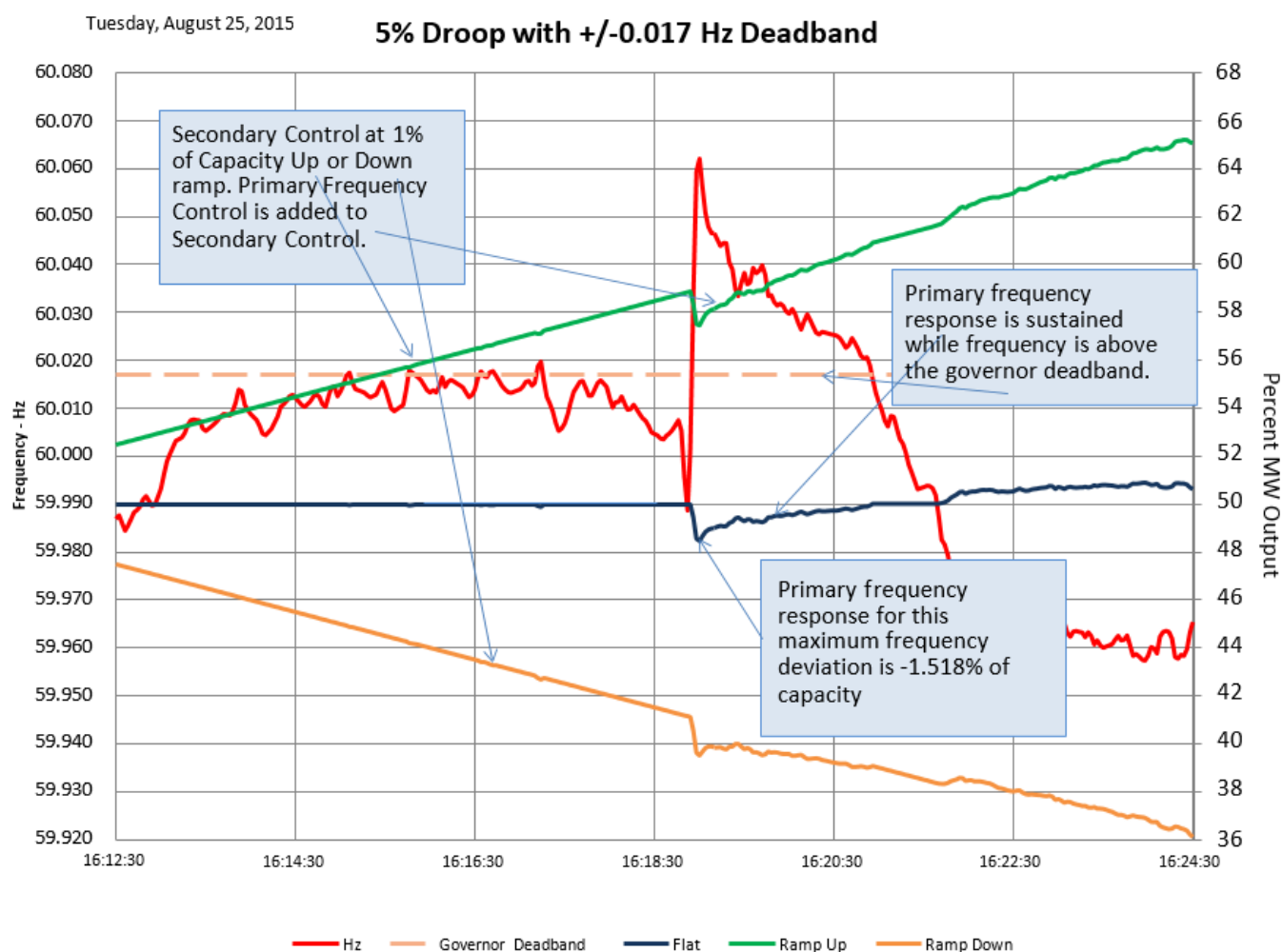

Figure 3.4: Example of Properly Coordinated Primary Frequency Control while Ramping MW Up or Down Via Local or Remote Control or while Operating at a Fixed MW Output in the Graph Above - High Frequency Excursion with a Lower Deadband (Deadband = 17 mHz)

Ability of Natural Gas Turbines to Sustain Primary Frequency Response Following Large Loss-of-Generation Events

Combustion turbine/generators are important contributors to arrest system frequency following a sudden loss of generation. However, if an under-frequency event calls for maximum output from a combustion turbine/generator, this output may not be sustainable due to reduced air flow, the working fluid of these engines, and the actions of the exhaust temperature limit protection system of the turbine. At less than nominal frequency, the combustion turbine/generator rotates more slowly and moves less air into/through the combustion process. Burning the same or greater amount of fuel with less air results in higher exhaust gas temperature. If exhaust gas temperatures exceed a preset limit, the combustion turbine/generator will reduce output automatically to protect the turbine from damage. Unlike the withdrawal of response by plant load-controls, reduction of output by this means cannot be deactivated at the discretion of the plant operator.

Moreover, there is linkage between the exhaust gas temperature protection system and system frequency that can be detrimental to reliable interconnection frequency response. If system frequency continues to be depressed or decline as the exhaust gas temperature controls reduce turbine output, then the temperature limit controls will further reduce turbine output.

Figure 3.5 illustrates this effect. The lower panel shows the control actions directed by the turbine-governor (red) and the exhaust gas temperature protection system (blue). Initially, the turbine-governor, responding to the decline in interconnection frequency, directs increased fuel flow to the turbine thus increasing the combustion rate and MW output. Once the turbine exhaust has reached its temperature limit, the protection system overrides the turbine-governor and directs lower levels of fuel flow until the exhaust temperature is below the limit. The top panel illustrates the impact these control actions could have on interconnection frequency when combustion turbine/generators predominate the generation mix in an interconnection and are operated near the exhaust temperature limit.

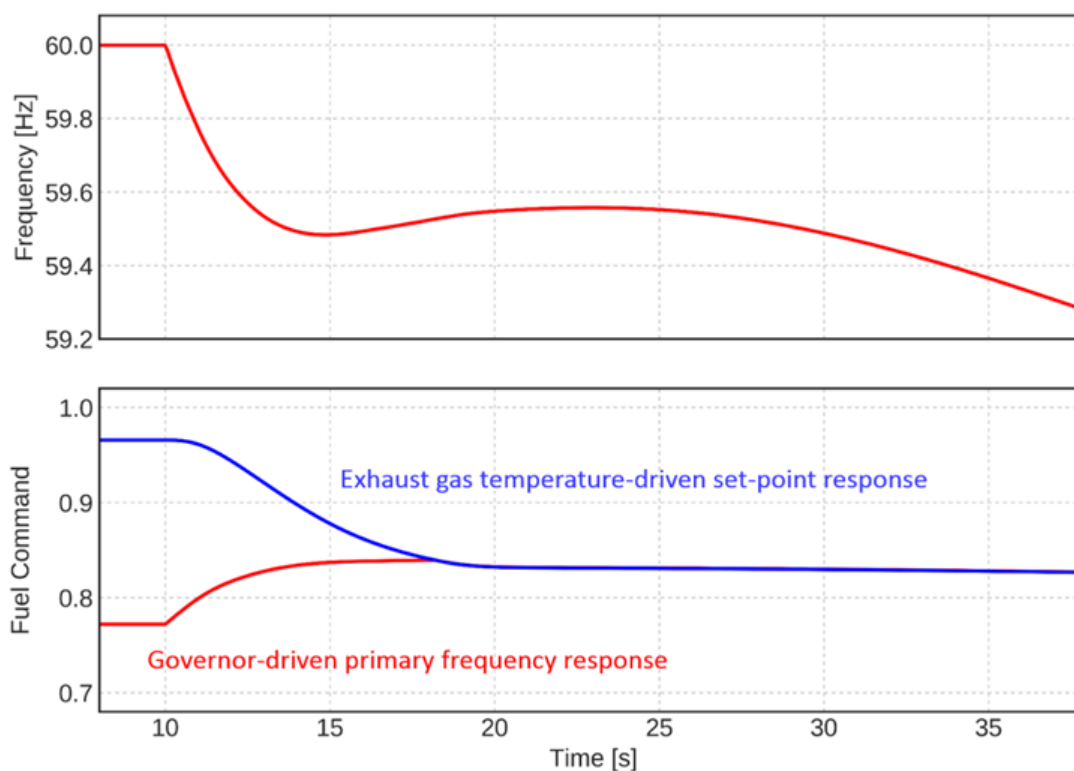

Figure 3.5: Exhaust Gas Temperature Controls on Gas Turbines Will Decrease Primary Frequency Response if Frequency Remains Depressed⁵

As noted, the effect of these controls cannot be overridden; they are intrinsic to the design of protection for the turbine. This reduction is better thought of as a reduction in the headroom or PFR capability of the natural gas turbine, rather than a form of withdrawal of PFR.

Primary Frequency Response from Inverter-Based Resources

Inverter-based resources (IBR) are capable of providing primary response in accordance with the common droop rule of the grid. IBRs have demonstrated their ability to respond to frequency deviation events in various Interconnections,⁶ including ERCOT,⁷ where it is a requirement. Most IBRs operate at maximum available output based on the availability of solar irradiance or wind speed. As a result, IBRs normally do not have headroom to provide PFR to low frequency events, but IBRs can provide very effective PFR to high frequency events. There are instances, however, where the resource may be curtailed; in these cases, IBRs would have the ability to provide PFR to frequency dips. IBRs normally have enough “down headroom” to provide PFR to high frequency events. More detailed guidance

⁵ Source: Developed by LBNL from Undrill (2018): *Primary Frequency Response and Control of Power System Frequency*

⁶ [Demonstration of Essential Reliability Services by a 300-MW Solar Photovoltaic Power Plant](#)

⁷ [Advanced Grid-Friendly Controls Demonstration Project for Utility-Scale PV Power Plants](#)

on effective control settings, frequency measurement resolution, and speed of PFR delivery for IBRs is available in the *Power Plant Model Verification for Inverter-Based Resources Reliability Guideline*.⁸

Fast Frequency Controls on Electronically Coupled Wind Generation and Sustained Primary Frequency Response

Most modern wind turbines are Type 3 (doubly fed induction generator) or Type 4 (full-scale converter generator) and are designed to allow operation at variable speed to achieve greater efficiency. However, variable speed operation requires generator speed and system frequency to be decoupled from each other via use of power electronic converters. As a result, even though kinetic energy is stored in the rotating mass of a wind turbine, variable speed wind turbines do not inherently provide inertial response to grid disturbances. Inertia itself is not a substitute for primary frequency control because inertia, whether synthetic or real, is not a sustained source of energy injection; however, it continues to oppose frequency change in real time.

Fast frequency control systems have been developed by several wind turbine manufacturers to allow the kinetic energy stored in the rotating mass of a wind turbine to be extracted and provide temporary active power to the grid in response to a frequency trigger during low frequency events. Such fast response is not considered to be PFR because it cannot be sustained unless the resource is operating under a curtailment.

Figure 3.6 shows the actual performance of a specific Type 3, 1.5 MW wind turbine equipped with “rotor inertia-based Fast Frequency Response” functionality for varied wind speeds. At 14 m/s (above nominal wind speed) there is no recovery phase. At 11.5 m/s, just below nominal wind speed, the recovery phase is the most demanding. Fast frequency control response decreases drastically at 50 percent of rated power and drops to zero at 20 percent of rated power, this is illustrated by 5 m/s (blue) trace below. This response is not proportional to frequency change and the same response will be provided for the same wind conditions for all frequency events.

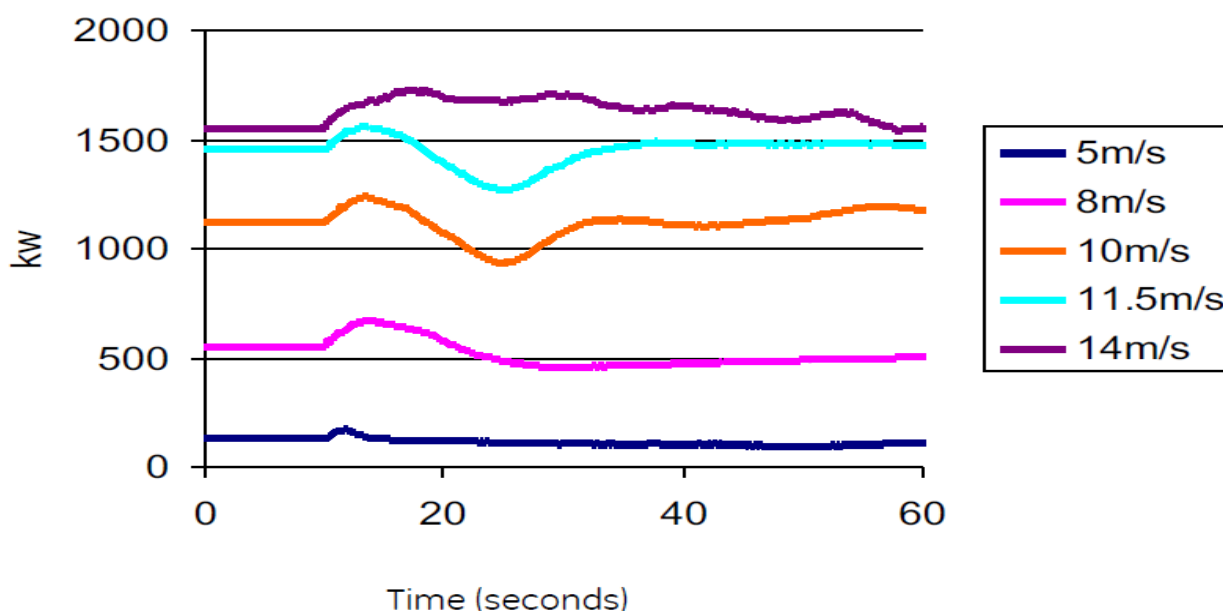

Figure 3.6: Fast Frequency Control Response of Wind Turbine at Different Wind Speed Conditions

⁸ https://www.nerc.com/comm/RSTC_Reliability_Guidelines/PPMV_for_Inverter-Based_Resources.pdf

It is important to recognize that the value of fast frequency control response is in energy being delivered during the arresting period to “buy” time for conventional PFR to act. Failing to sustain fast frequency response beyond the frequency nadir may lead to a prolonged recovery period. With that in mind, PFR coupled with fast frequency response from energy storage resources (activated only when headroom is allocated) and faster frequency response from IBRs with stored energy that can be tapped can help in the arresting period and is also sustained. To be beneficial to the power system, fast frequency control settings must be tuned to specific systems needs and various operating conditions. Additional details about fast frequency controls can be found in *Technology Capabilities for Fast Frequency Response*,⁹ which was published by GE Energy Consulting in March 2017.

⁹<https://www.nrel.gov/docs/fy17osti/67799.pdf>

Chapter 4: Governor Deadband and Governor Droop Settings

This guideline proposes maximum governor deadband and governor droop settings to achieve desired frequency response for each of the Interconnections while subject to other technical, operational, or regulatory considerations that would prevent governors from achieving the particular governor settings. Although there are recommended governor deadband maximums for two of the Interconnections at 36 mHz, it should be noted that deadbands of 0 and 17 mHz have been successfully implemented for several generating resource types. Governor deadbands are recommended to be implemented without a step into the droop curve. A step in the droop curve exposes the generator to excessive cycling when frequency dithers about the deadband limit. An example of each scenario can be seen in **Figure 4.1** (recommended) and **Figure 4.2** (not recommended). A more detailed discussion of the two methods (step and no-step) can be found in **Appendix B:** of *Dynamic Models for Turbine-Governors in Power System Studies*,¹⁰ which was published by the IEEE PES in January 2013. A larger percent droop value is less responsive to frequency deviations (e.g., a five percent droop is less responsive than a three percent droop).

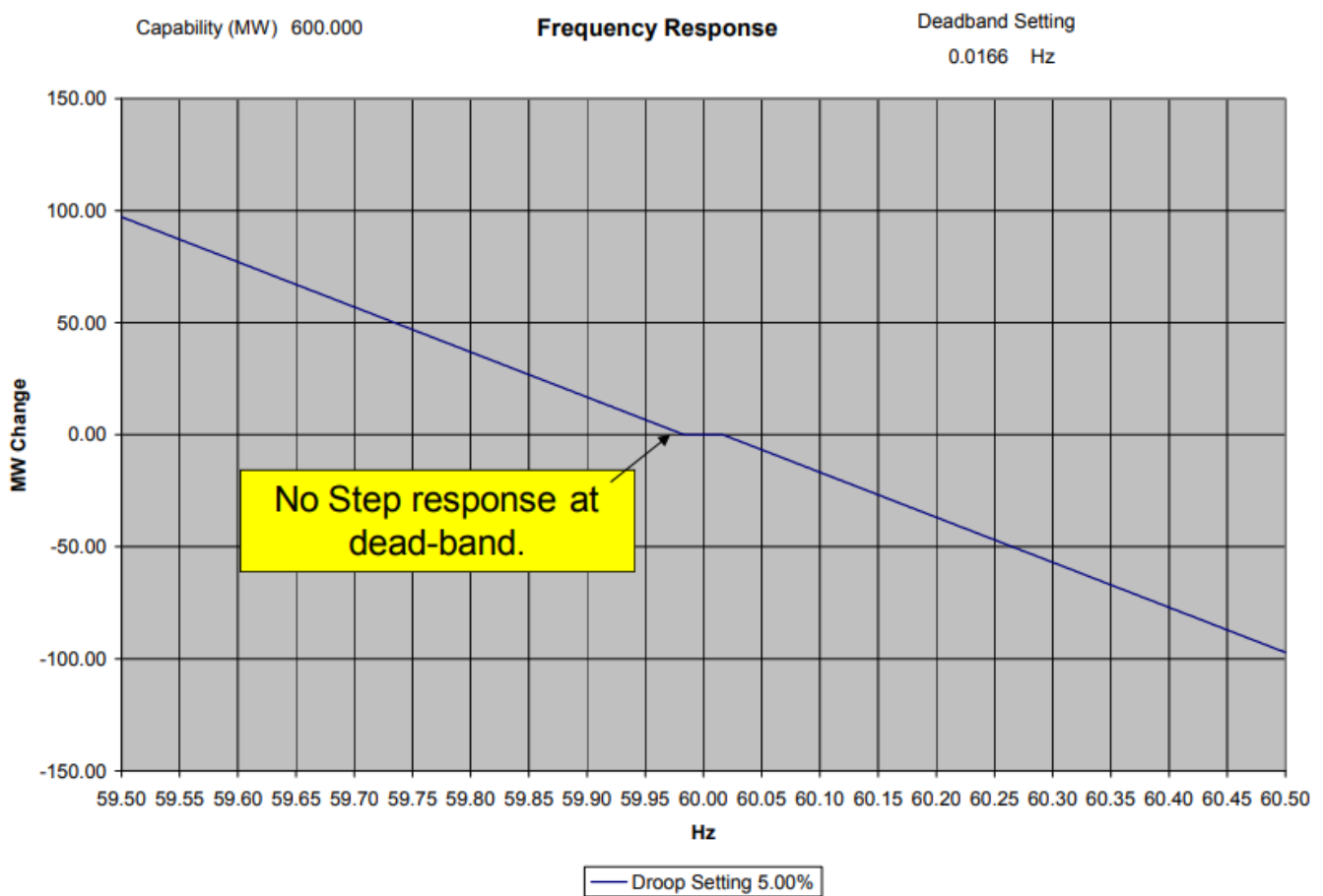

Figure 4.1: Governor Deadband Setting without Step Implementation¹¹¹²

¹⁰ http://sites.ieee.org/fw-pes/files/2013/01/PES_TR1.pdf

¹¹ Source: NERC Frequency Response Initiative Report 2012¹¹

¹² https://www.nerc.com/docs/pc/FRI_Report_10-30-12_Master_w-appendices.pdf Frequency Response Initiative Report 2012

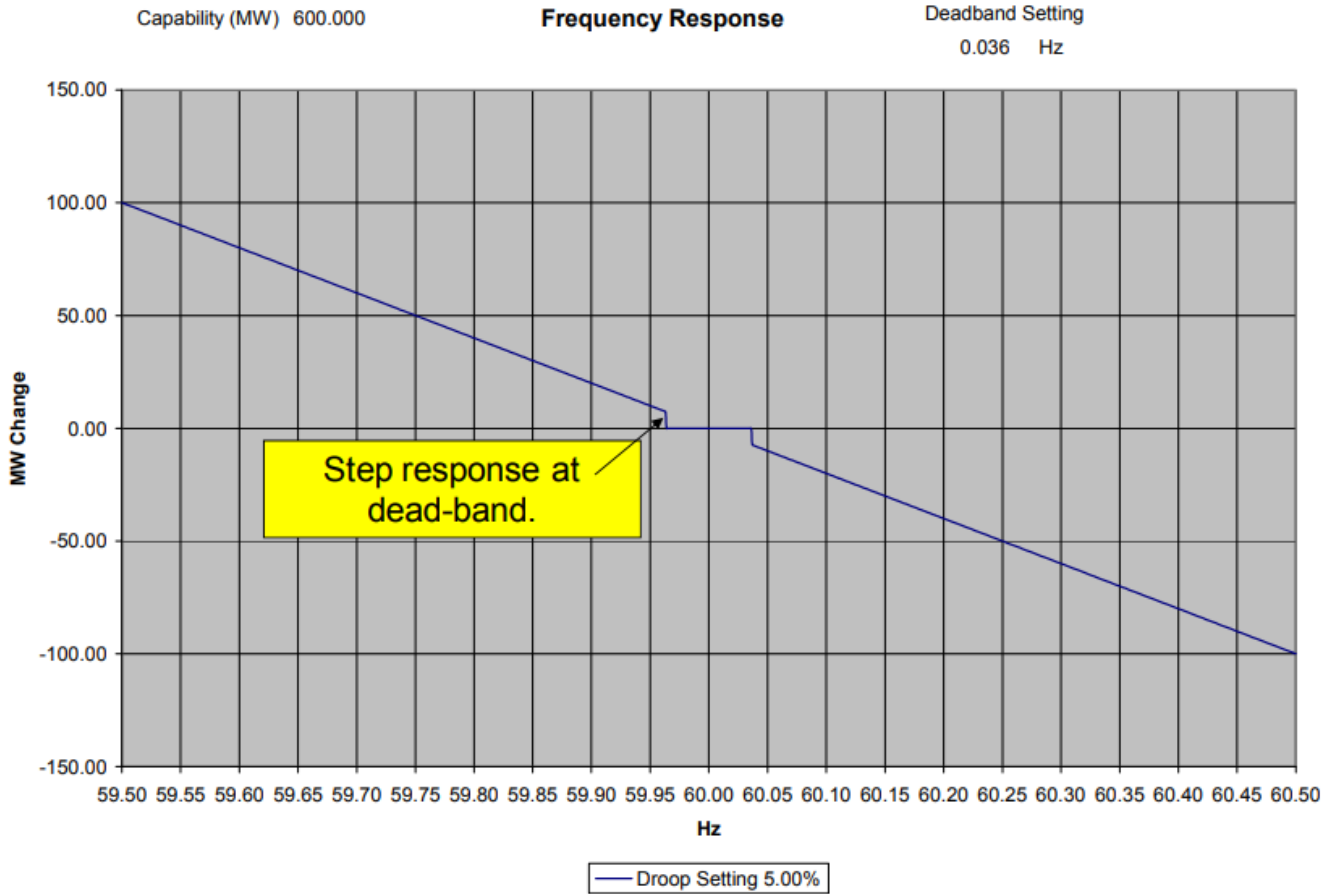

Figure 4.2: Governor Deadband Setting with Step Implementation¹³

The recommended maximum governor deadband and governor droop settings for each Interconnection are as follows in this section.

Eastern Interconnection

The recommended governor deadband setting should not exceed the value stated in [Table 4.1](#).

Table 4.1: Eastern Interconnection Deadband Settings	
Generator Type	Maximum Deadband Setting
All Generating Units	+/- 0.036 Hz

The maximum expected droop performance for the entire combined-cycle facility is six percent. The effective droop of a combined-cycle plant depends on the size of the steam turbine generator in proportion to the sum of the natural gas turbine generators. Many combustion turbines in a combined-cycle configuration have a four percent droop setting. The recommended governor droop settings should not exceed the values in [Table 4.2](#) for each type of generator.

¹³ Source: NERC Frequency Response Initiative Report 2012

Table 4.2: Eastern Interconnection Droop Settings

Generator Type	Maximum Droop Setting
Combustion Turbine (Combined Cycle)	4%
Steam Turbine (Combined Cycle)	5%
All Others	5%

ERCOT Interconnection

The required governor deadband setting shall not exceed the values in [Table 4.3](#) from BAL-001-TRE.

Table 4.3: ERCOT Interconnection DeadBand Settings

Generator Type	Maximum Dead-Band Setting
Steam and Hydro Turbines with Mechanical Governors	+/- 0.034 Hz
All Other Generating Units/Generating Facilities	+/- 0.017 Hz

The required governor droop settings shall not exceed the values in [Table 4.4](#) for each respective type of generator from BAL-001-TRE.

Table 4.4: ERCOT Interconnection Droop Settings

Generator Type	Maximum Droop Setting
Hydro	5%
Nuclear	5%
Coal and Lignite	5%
Combustion Turbine (Simple Cycle and Single-Shaft Combined Cycle)	5%
Combustion Turbine (Combined Cycle)	4%
Steam Turbine (Simple Cycle)	5%
Diesel	5%
Wind Powered Generator	5%
DC Tie Providing Ancillary Services	5%
Renewable (Non-Hydro)	5%

Western Interconnection

The recommended governor deadband setting should not exceed the value in [Table 4.5](#).

Table 4.5: Western Interconnection Deadband Settings

Generator Type	Maximum Deadband Setting
All Generating Units	+/- 0.036 Hz

The governor droop settings shall not be less than three percent or greater than five percent. Many combustion turbines have a four percent droop setting. The droop settings should not exceed the values in [Table 4.6](#) for each respective type of generator.

Table 4.6: Western Interconnection Droop Settings

Generator Type	Maximum Droop Setting
Combustion Turbine (Combined Cycle)	4%
Steam Turbine (Combined Cycle)	5%
All Others	5%

Quebec Interconnection

There shall be no intentional governor deadband set on generators within the Quebec Interconnection by local requirement, shown in [Table 4.7](#).

Table 4.7: Quebec Interconnection Deadband Settings	
Generator Type	Maximum Deadband Setting
All Generation	N/A

The required governor droop settings shall not exceed five percent for all types (synchronous, inverter based and other technologies) of generation within the Quebec Interconnection by local requirement (see [Table 4.8](#)).

Table 4.8: Quebec Interconnection Droop Settings	
Generator Type	Maximum Droop Setting
All Generation	5%

Chapter 5: Performance Assessment

Some BAs have developed methods for determining if governors are working properly by reviewing energy management system scan rate data (e.g., every four seconds) stored in their data historians (e.g., OSISoft, PI, AVEVA eDNA). Verification of proper governor function within a BA can be time consuming and requires specific expertise. BAs are strongly encouraged to evaluate the governor's responses being provided within their BA area to an adequate FRR is available in real time. To assist in this effort, methods used successfully by some BA to address this task are presented below and may be used as a starting point for similar efforts of other BAs, GOPs, and GOs.

The ERCOT Interconnection is a single BA Interconnection and has developed metrics to evaluate governor response performance. These metrics are included in the Regional Reliability Standard BAL-001-TRE-1, Attachment 1 "Primary Frequency Response Reference Document." BAL-001-TRE-1 Attachment A provides performance metric calculations for initial PFR, sustained PFR, and limits on calculation of PFR performance¹⁴. PFR uses a fixed time interval to determine initial governor response to a frequency event. Sustained PFR also establishes a fixed time interval; this time is used to determine if frequency response is being sustained through the stabilization period. High scores on both metrics indicate that frequency response is being sustained as desired. Low scores on both can indicate that frequency response is not being provided. Problems with outer loop control causing frequency response to be withdrawn (i.e., squelched response) can be indicated by a relatively high score in the initial PFR metric and a lower score in sustained PFR metric.

NERC also uses a similar tool to that of ERCOT, known as the Generator Resource Survey, to calculate governor PFR by using historical data or manually calculated values. This tool, which uses the NERC Reliability Standard BAL-001-TRE-1 as a starting framework, evaluates an individual resource's ability to provide PFR during both the initial period and the sustained period. This tool is used for single event and unit evaluation and is intended to be used as a benchmarking tool for an individual resource as well as for the BA. It evaluates resources for their ability to provide PFR much like the BAL-001-TRE-1 except for a few notable differences. Those differences include the lack of consideration of certain aspects of conventional steam turbine operation and natural gas turbine and combined-cycle operation due to lack of data availability to many BAs and GOs. The survey is intended to be a starting point for the evaluation of resources and their ability to provide PFR through both the initial excursion of a frequency event as well as during the arresting/stabilization period during the recovery.

Several NPCC BAs within the NPCC Region have used a graphical approach to determining if generator governor response is being sustained. Two plots of generator output and frequency are reviewed in the evaluation of a generator's response along with some supplemental data. The first plot (starting five minutes before the decline in frequency and ending 15 minutes after the decline in frequency) is used to determine if other factors (e.g., such as unit ramping or AGC control) are occurring, which may invalidate the utility of the sample (i.e., it is not a "controlled" experiment). The second plot (starting one minute before the decline in frequency and ending two minutes after the decline in frequency) is used to determine the type of response observed and to calculate an observed droop if the response is being sustained. The analysis performed is a three-step process: sample validation, response type classification, and droop verification. The process is explained further in [Appendix B](#). A fixed time window is not used in the response type classification and droop verification because Eastern Interconnection frequency deviations often persist for longer than one minute, and frequency response should be sustained until the frequency returns to a value within the governor deadband.

¹⁴ [BAL-001-TRE-2](#)

Appendix A: Typical Unit Response to Low and High Frequency Events by Unit Type

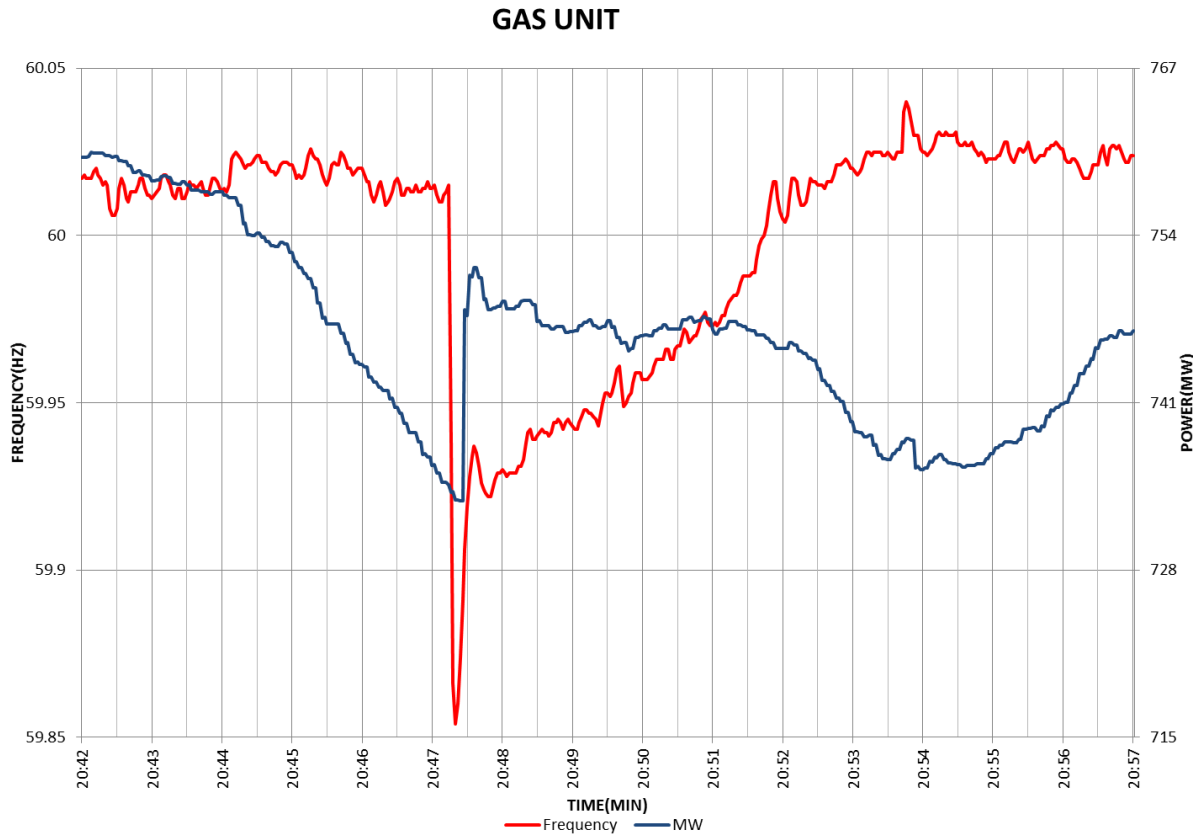

Figure A.1: Gas Unit Responding to Low Frequency Event at 17 mHz Deadband and Five Percent Droop

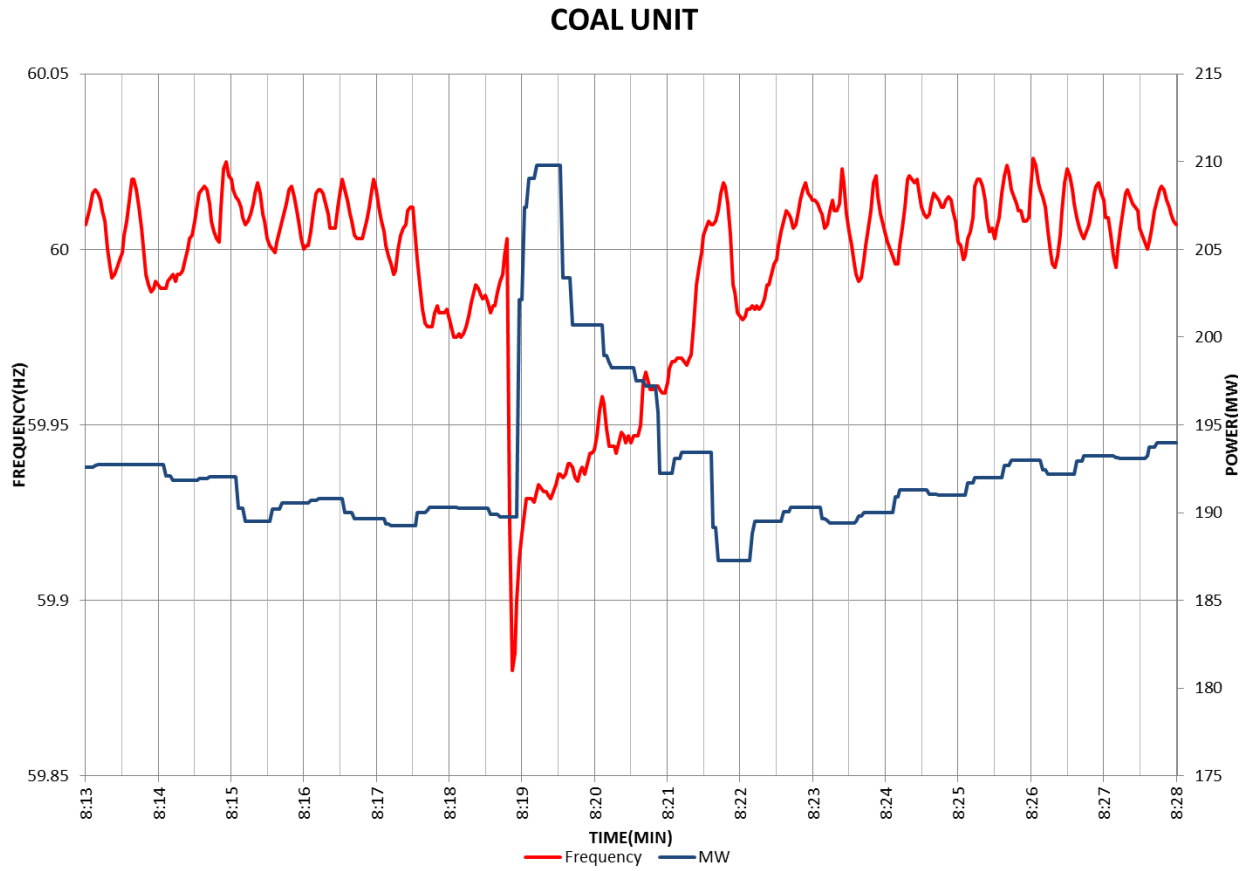

Figure A.2: Coal Unit Responding to Low Frequency Event at 17 mHz Deadband and Five Percent Droop

COMBINED CYCLE

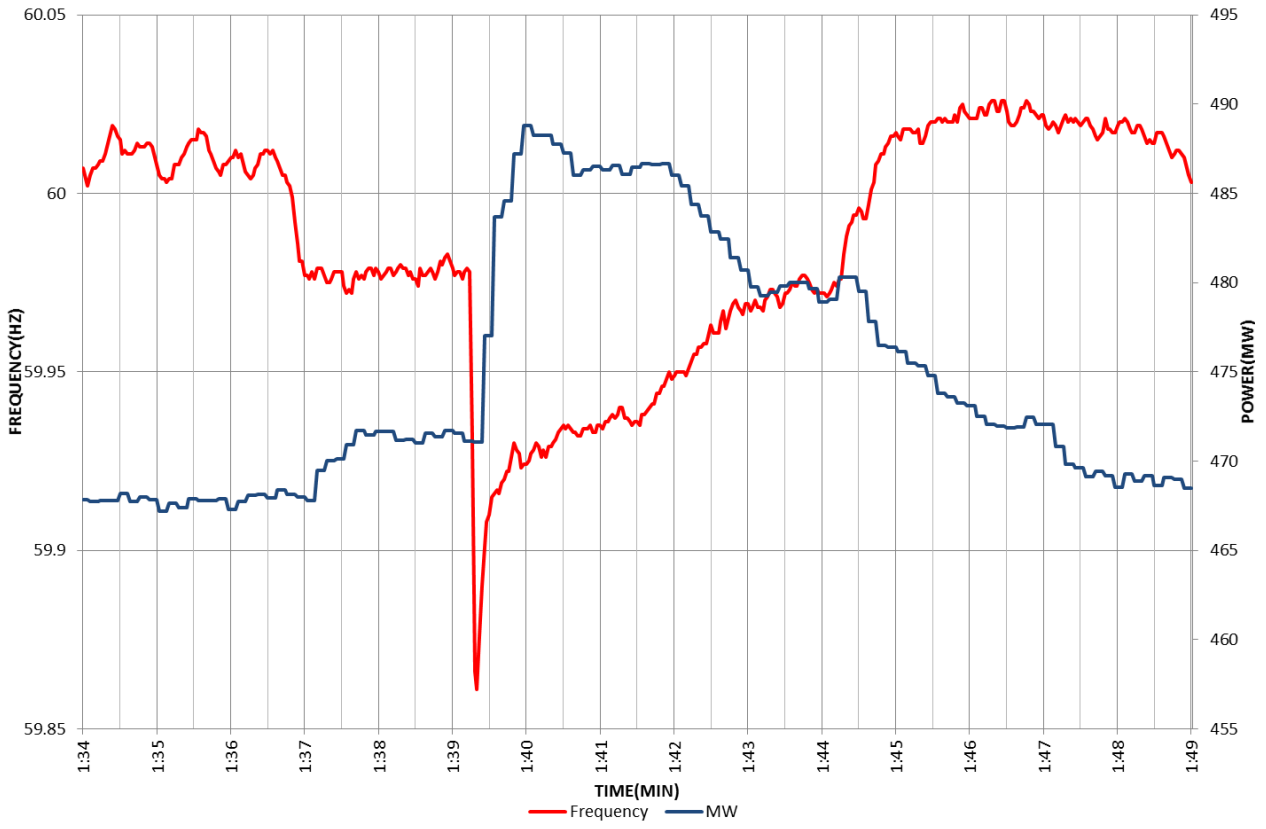

Figure A.1: Combined-Cycle Unit/Block Responding to Low Frequency Event at 17 mHz Deadband

WIND

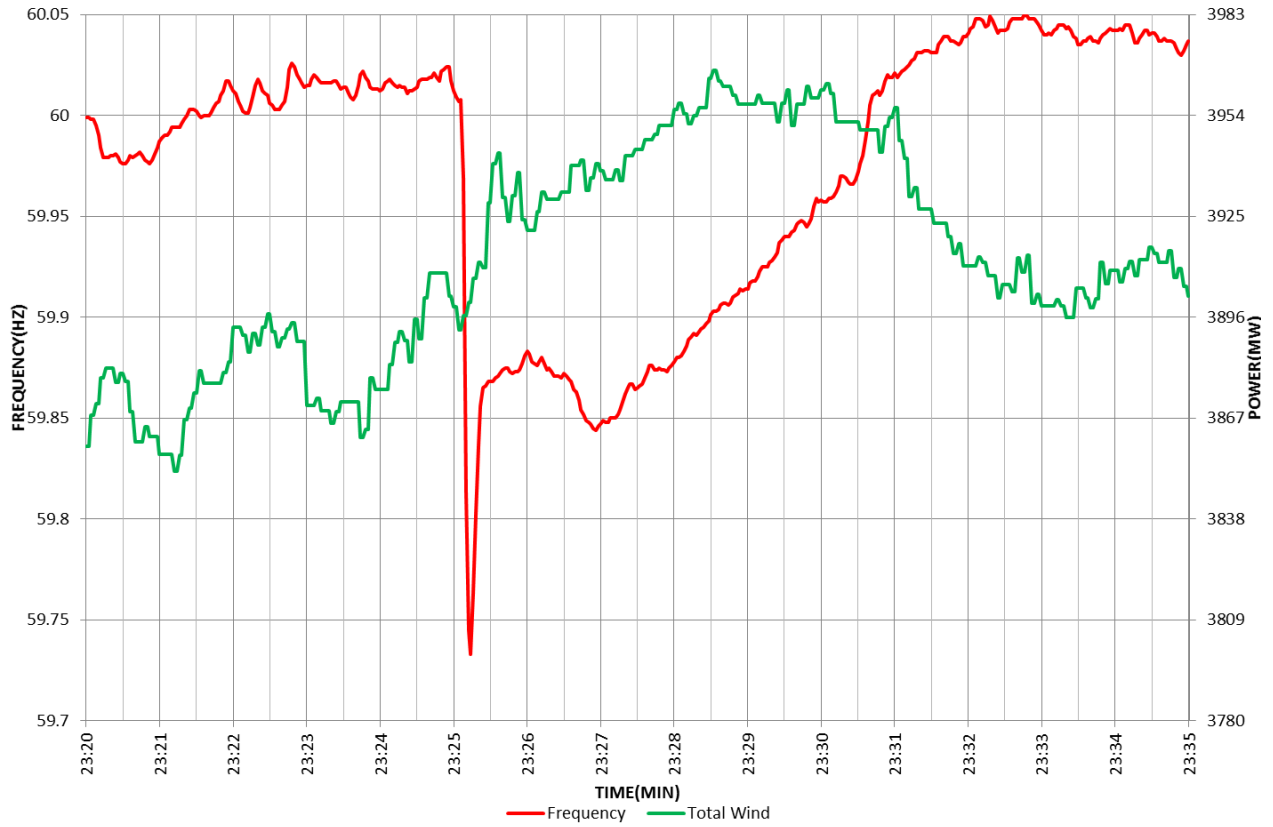

Figure A.4: Wind Resources Responding to Low Frequency Event at 17 mHz Deadband and Five Percent Droop

WIND

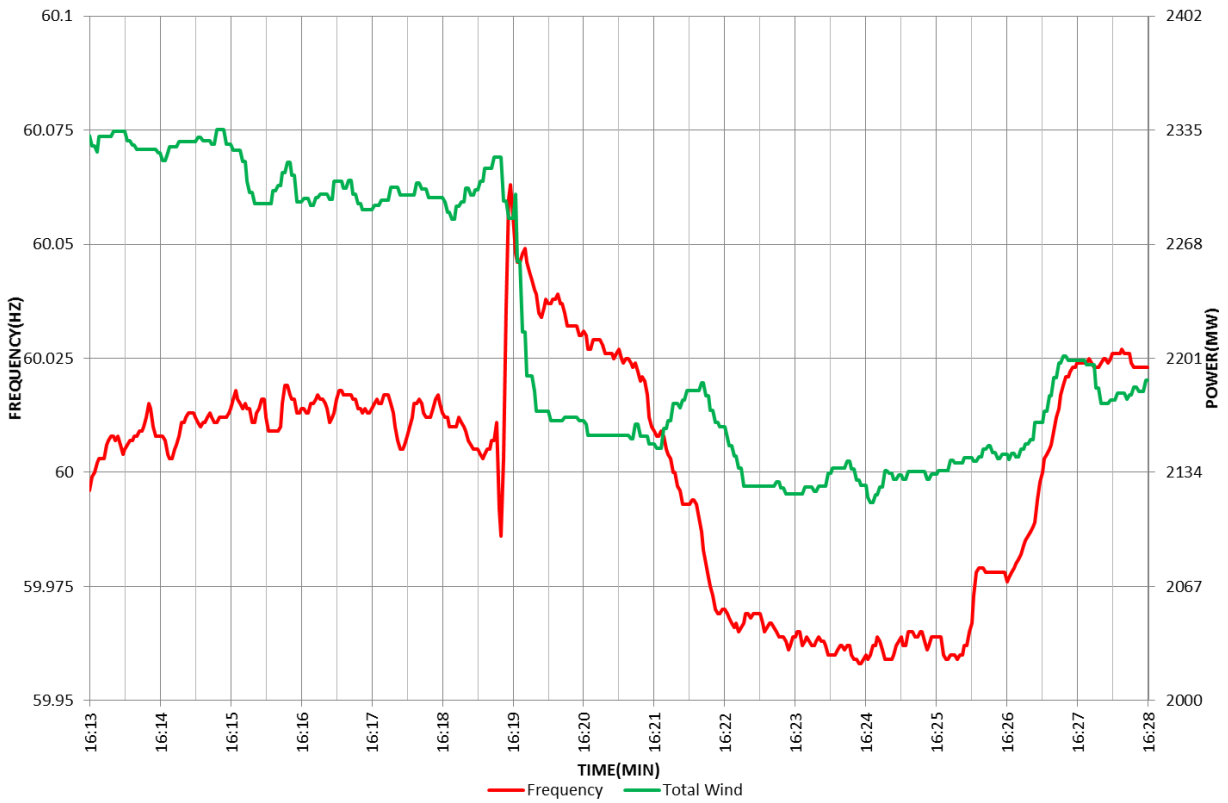

Figure A.5: Wind Resources Responding to High Frequency Event at 17 mHz Deadband and Five Percent Droop

HYDRO UNIT

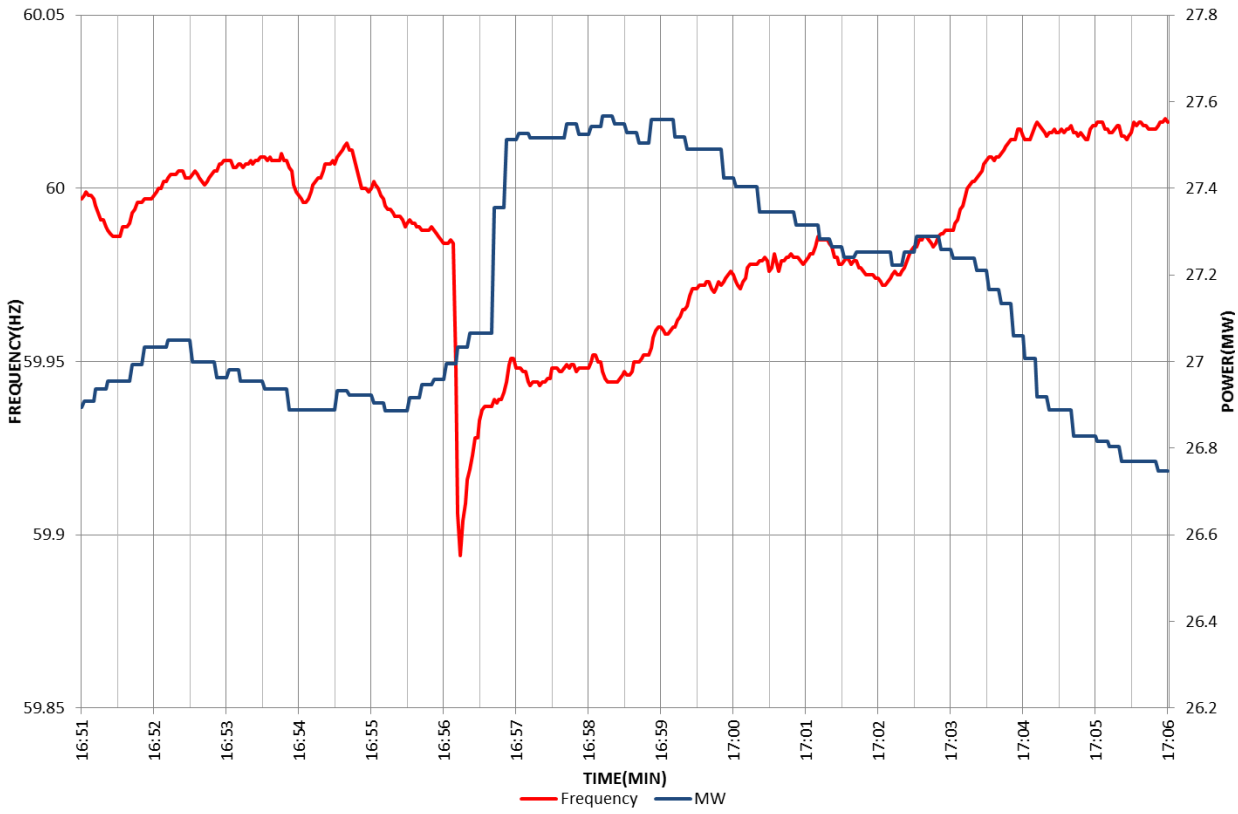

Figure A.6: Hydro Resource Responding to Low Frequency Event at 17 mHz Deadband and Five Percent Droop

SOLAR UNIT

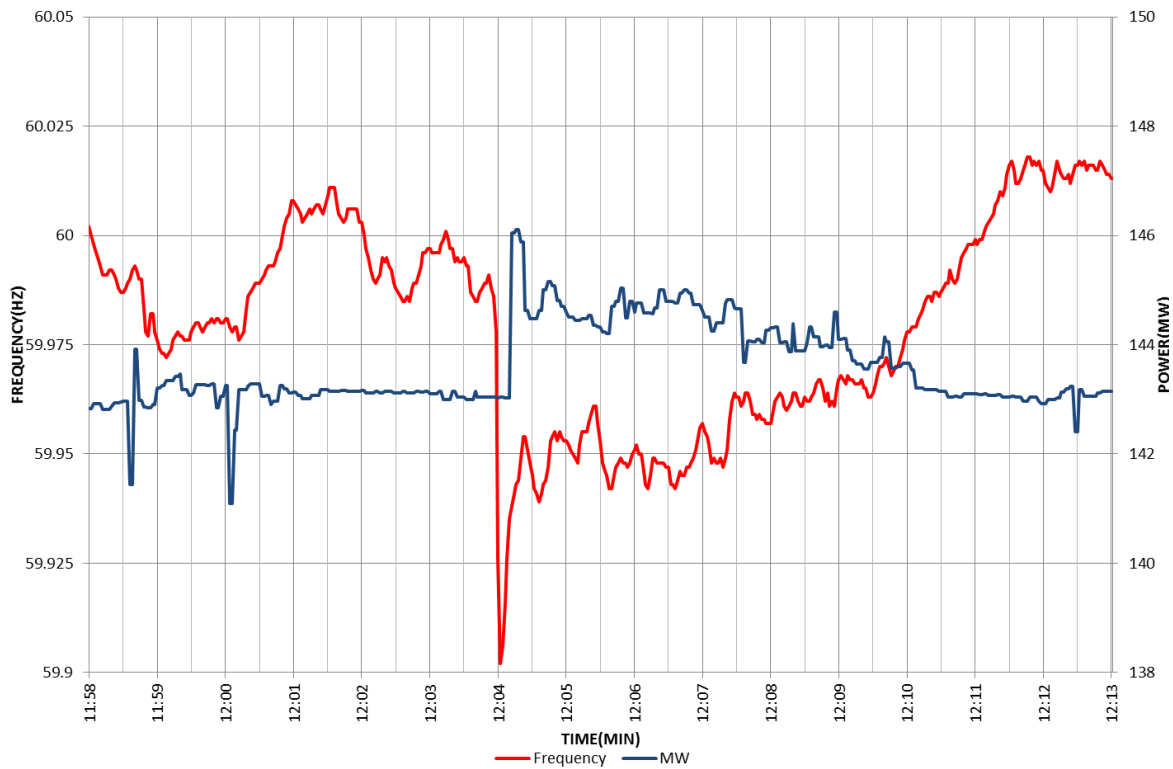

Figure A.7: Solar Resource Responding to Low Frequency Event at 17 mHz Deadband and Five Percent Drop in ERCOT

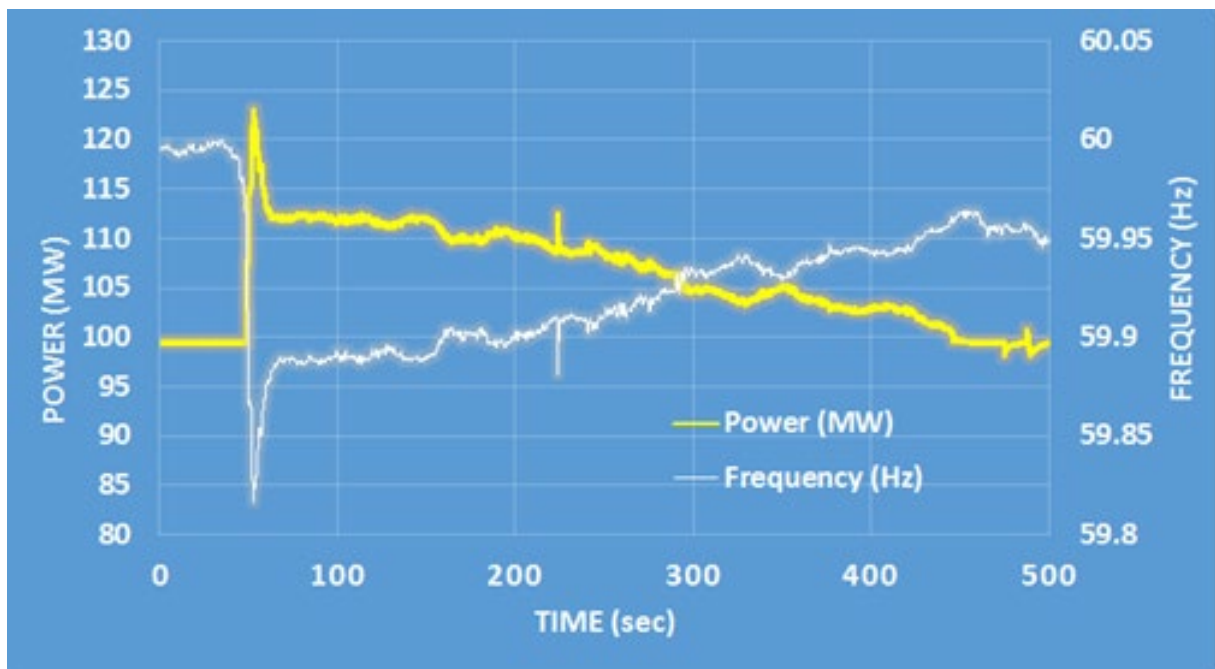

Figure A.8: Solar Resource Responding to Low Frequency Event at 36 mHz Deadband and Three Percent Drop in WECC

Appendix B: Sample Validation, Response Type Classification, and Droop/Deadband Verification

Sample Validation

There are several factors to be considered in determining if a particular declining frequency event can provide useful information about the frequency response of a particular generator. Any one of the following factors can reduce the confidence in or totally invalidate the performance sample:

- Poor signal resolution from the plant historian.
- Historian compression techniques duration and extent of frequency excursion beyond the expected governor deadband limit.
- Oscillatory generator output due to plant control tuning problems.
- Generator is off-line, ramping up or down due to dispatch instructions, or on AGC.
- Output is at or near the generator high limit at the time of the frequency event.
- Insufficient accuracy of the data acquisition system to measure and record the measured parameters.
- Noisy telemetry of the output of the generator.
- Actual high limit's sensitivity to ambient temperature versus a high limit provided based on forecasted temperature.
- Higher levels of output provided by equipment that is not frequency responsive (e.g., duct burners, steam injection).

Response Type Classification

Once a sample for a declining frequency event has been validated, an attempt is made to classify a sample as one of the following types based on a review of the plots of actual generation and frequency:

- Sustained: Output increases after the frequency deviates outside the governor deadband with frequency response that is proportional to the ongoing frequency deviation beyond the governor deadband continuing until the frequency returns to be within the governor deadband.
- Withdrawal/Squelched: Output increases after the frequency deviates outside the frequency deadband, but it decreases significantly in the direction of the output level that existed prior to the decline in frequency even though the frequency continues to be outside the governor deadband.
- No Response: Output is essentially unchanged when the frequency deviates outside the governor dead-band.
- Negative Response: Output declines as the frequency declines, possibly due to thermal limitations or improper configuration of plant controls.

Individual samples are compared to determine an overall response type classification and repeatability among samples is a key factor in this determination. A high degree of confidence in the overall classification can be developed when five to 10 samples exhibit the same response type. However, an overall assessment of squelched response may require a greater number of samples as the relative values of actual generation versus the desired dispatch level and its surrounding megawatt control deadband can result in a mixture of response types among samples. For example, out of 20 samples, six may appear to be sustained, six may appear to be squelched, six may appear to have no response, and two may appear to be negative responses.

Governor Deadband and Droop Verification

For generators classified as having sustained response, the governor deadband and governor droop settings can be verified. An expected output change for a declining frequency event can be computed based on generator size, governor deadband expected governor settings, and the frequency observed when it is relatively stable prior to the event. The computed expected response can be compared with the actual observed change in output. Greater confidence in this verification can be achieved if the mean and median of about ten events are used in the comparison.

If the droop and deadband settings are not known, but there are about 10 samples of sustained response, trial droop and deadband values can be used to estimate an effective droop/deadband pair by matching the mean and median of the observations with those expected for candidate droop/deadband pairs.

The empirical/effective droop settings can vary substantially for some conventional thermal generators based on load levels. For some generators, it may be necessary to compute different effective droop values for different output ranges. The droop rating is applicable to the entire operating range while droop performance can vary depending on the initial load (and its corresponding governor valve position) when a frequency event occurs.

Appendix C: Definitions and Terminology

Area Control Error (ACE): The instantaneous difference between a Balancing Authority's net actual and scheduled interchange, taking into account the effects of Frequency Bias, correction for meter error, and Automatic Time Error Correction (ATEC) if operating in the ATEC mode. ATEC is only applicable to BAs in the WI.

Arrested Frequency – Value C – Point C – Frequency Nadir: The point of maximum frequency excursion in the first swing of the frequency excursion between time zero (Point A) and time zero plus 20 seconds.

Arresting Period: The period of time from time zero (Point A) to the time of Point C.

Arresting Period Frequency Response: A combination of load damping and the initial Primary Control Response acting together to limit the duration and magnitude of frequency change during the Arresting Period.

Automatic Generation Control (AGC): Equipment that automatically adjusts generation in a Balancing Authority Area from a central location to maintain the BA's interchange schedule plus Frequency Bias. AGC may also accommodate automatic inadvertent payback and time error correction.

Balancing Authority (BA): The responsible entity that integrates resource plans ahead of time, maintains load-interchange-generation balance within a BA Area, and supports interconnection frequency in real time.

Frequency: The rate at which a period waveform repeats itself. Frequency is measured in cycles per second or in hertz (Hz). The symbol is "f."

Frequency Deviation: A difference between the interconnection frequency and the interconnection scheduled frequency.

Frequency Responsive Reserve: The capacity of Governor Response and/or Frequency-Responsive Demand Response that will be deployed for any frequency excursion.

Frequency-Responsive Demand Response: Voluntary load shedding that complements governor response. This load reduction is typically triggered by relays that are activated by frequency.

Headroom: The difference between the current operating point of a generator and its maximum operating capability.

Inertia: The property of an object that resists changes to the motion of an object. For example, the inertia of a rotating object resists changes to the object's speed of rotation. The inertia of a rotating object is a function of its mass, diameter, and speed of rotation.

Load Damping: The damping effect of the load to a change in frequency due to the physical aspects of the load such as the inertia of motors and the physical load to which they are connected.

Plant Secondary Control: Secondary control refers to controls affected through commands to a turbine controller issued by external entities not necessarily working in concert with frequency management objectives. It is common for a modern power plant to have several distinct modes of secondary control implemented within the plant and to be able to accept secondary control inputs from sources external to the plant.

Primary Control Response Withdrawal: The withdrawal of previously delivered Primary Control Response, through plant secondary controls.

Primary Frequency Control: Actions that deliver power to the interconnection in response to a frequency deviation through inertial response generator governor response, load response (typically from motors), demand response (designed to arrest frequency excursions), and other devices that provide an immediate response to frequency based on local (device-level) control systems, without human or remote intervention.

Recovery Period: The period of time from when Secondary Control Response are deployed (typically about zero plus 53 seconds) to the time of the return of frequency to within pre-established ranges of reliable continuous operation.

Settling Frequency: Refers to the third key event during a disturbance when the frequency stabilizes following a frequency excursion. Point B represents the interconnected system frequency at the point immediately after the frequency stabilizes due to governor action but before the contingent control area takes corrective AGC action.

Secondary Frequency Control: Actions provided by an individual BA or its Reserve Sharing Group intended to restore Primary Control Response and restore frequency from the Arrested Frequency back to Scheduled Frequency, or to maintain Scheduled Frequency deployed in the “minutes” time frame. Secondary Control comes from either manual or automated dispatch from a centralized control system. Secondary Control also includes initial reserve deployment for disturbances and maintains the minute-to-minute balance throughout the day and is used to restore frequency to normal following a disturbance and is provided by both spinning and non-spinning reserves.

Tertiary frequency control: Encompasses actions taken to get resources in place to handle current and future changes in load or contingencies. Reserve deployment and Reserve restoration following a disturbance is a common type of Tertiary frequency control.

Appendix D: Related Documents

Frequency Control Requirements for Reliable Interconnection Frequency Response – Lawrence Berkeley National Laboratory

FERC Order 842

Reliability Guideline: Operating Reserve Management – Version 3

Demonstration of Essential Reliability Services by a 300-MW Solar Photovoltaic Power Plant

Advanced Grid-Friendly Controls Demonstration Project for Utility-Scale PV Power Plants

[Fast Frequency Response Concepts and Bulk Power System Reliability Needs - White Paper](#)

IEEE PES Appendix B of “Dynamic Models for Turbine-Governors in Power System Studies”

Frequency Response Initiative Report - The Reliability Role of Frequency Response October 30, 2012

NERC Alert A-2015-02-05-01

BAL-001-TRE-1 Attachment A

[Using Renewables to Operate a low-carbon Grid: Demonstration of Advanced Reliability Services from a Utility-Scale Solar PV Plant](#)

PRC-001-WECC-CRT-2.1

Contributors

NERC gratefully acknowledges the contributions and assistance of the following industry experts in the preparation of this guideline.

Name	Entity
Troy Blalock	Dominion Energy South Carolina
Nitika Mago	ERCOT
Greg Park	Western Power Pool
Sam Rugel	Tucson Electric Power Company
William Shultz	Southern Company Generation/ NAGF member
Terry Bilke	Consultant
Darrel Richardson	North American Electric Reliability Corporation
Levetra Pitts	North American Electric Reliability Corporation

Guideline Information and Revision History

Guideline Information	
Category/Topic: Balancing	Reliability Guideline/Security Guideline/Hybrid: Primary Frequency Control
Identification Number: RG-BAL-0123	Subgroup: NERC Resource Subcommittee

Revision History		
Version	Comments	Approval Date
1.0	Initial Version – <i>Reliability Guideline: Primary Frequency Response</i>	12/15/2015
2.0	Updated Document to include additional guidance for Primary Frequency Response	9/19/2018
3.0	Update document to include additional guidance for Primary Frequency Response	5/1/2019
4.0	Updated document to include references to IBRTF, added metrics and formatted to new guideline	9/20/2023

Metrics

Pursuant to the Commission's Order on January 19, 2021, *North American Electric Reliability Corporation*, 174 FERC ¶ 61,030 (2021), reliability guidelines shall now include metrics to support evaluation during triennial review consistent with the RSTC Charter.

Baseline Metrics

All NERC reliability guidelines include the following baseline metrics:

- BPS performance prior to and after a reliability guideline as reflected in NERC's State of Reliability Report and Long Term Reliability Assessments (e.g., Long Term Reliability Assessment and seasonal assessments)
- Use and effectiveness of a reliability guideline as reported by industry via survey
- Industry assessment of the extent to which a reliability guideline is addressing risk as reported via survey

Specific Metrics

The RSTC or any of its subcommittees can modify and propose metrics specific to the guideline in order to measure and evaluate its effectiveness, listed as follows:

- NERC M-4 Interconnection Frequency Response.
- NERC BAL- 003 compliance by BA or FRSG.

Effectiveness Survey

On January 19, 2021, FERC accepted the NERC proposed approach for evaluating Reliability Guidelines. This evaluation process takes place under the leadership of the RSTC and includes:

- industry survey on effectiveness of Reliability Guidelines;
- triennial review with a recommendation to NERC on the effectiveness of a Reliability Guideline and/or whether risks warrant additional measures; and
- NERC's determination whether additional action might be appropriate to address potential risks to reliability in light of the RSTC's recommendation and all other data within NERC's possession pertaining to the relevant issue.

NERC is asking entities who are users of Reliability and Security Guidelines to respond to the short survey provided in the link below.

[Effectiveness Survey](#)