

Standard Development Timeline

This section is maintained by the drafting team during the development of the standard and will be removed when the standard is adopted by the NERC Board of Trustees (Board).

Description of Current Draft

The standard drafting team (PRC 025) is posting Draft 1 of PRC-025-2, Generator Relay Loadability for a 45-day formal comment period and initial ballot in the last ten days of the comment period.

Completed Actions	Date
The Standards Committee (SC) authorized the SAR for posting	September 14, 2016
Draft 1 of the Standards Authorization Request (SAR) was posted for a 30-day formal comment period	September 16, 2016 through October 18, 2016
Draft 2 of the SAR was posted for a 15-day informal comment period	March 20, 2017 through April 3, 2017
The SC accepted the SAR and appointed the SAR drafting team as the standard drafting team (SDT)	April 19, 2017
Draft 1 of PRC-025-2 was posted for a 45-day formal comment period with an initial ballot conducted in the last 10 days of the comment period	July 25, 2017 through September 9, 2017
Draft 2 of PRC-025-2 was posted for a 45-day formal comment period with an additional ballot conducted in the last 10 days of the comment period	October 30, 2017 through December 14, 2017

Anticipated Actions	Date
45-day formal comment period with initial ballot	July 2017
45-day formal comment period with additional ballot	October 2017
10-day final ballot	January 2018
Board adoption	February 2018

New or Modified Term(s) Used in NERC Reliability Standards

This section includes all new or modified terms used in the proposed standard that will be included in the *Glossary of Terms Used in NERC Reliability Standards* upon applicable regulatory approval. Terms used in the proposed standard that are already defined and are not being modified can be found in the *Glossary of Terms Used in NERC Reliability Standards*. The new or revised terms listed below will be presented for approval with the proposed standard. Upon Board adoption, this section will be removed.

Term(s):

None.

A. Introduction

1. **Title:** Generator Relay Loadability
2. **Number:** PRC-025-12
3. **Purpose:** To set load-responsive protective relays associated with generation Facilities at a level to prevent unnecessary tripping of generators during a system disturbance for conditions that do not pose a risk of damage to the associated equipment.
4. **Applicability:**
 - 4.1. **Functional Entities:**
 - 4.1.1. Generator Owner that applies load-responsive protective relays¹ at the terminals of the Elements listed in 34.2, Facilities.
 - 4.1.2. Transmission Owner that applies load-responsive protective relays¹ at the terminals of the Elements listed in 34.2, Facilities.
 - 4.1.3. Distribution Provider that applies load-responsive protective relays¹ at the terminals of the Elements listed in 34.2, Facilities.
 - 4.2. **Facilities:** The following Elements associated with Bulk Electric System (BES) generating units and generating plants, including those generating units and generating plants identified as Blackstart Resources in the Transmission Operator's system restoration plan:
 - 4.2.1. Generating unit(s).
 - 4.2.2. Generator step-up (i.e., GSU) transformer(s).
 - 4.2.3. Unit auxiliary transformer(s) (UAT) that supply overall auxiliary power necessary to keep generating unit(s) online.²
 - 4.2.4. Elements that connect the GSU transformer(s) to the Transmission system that are used exclusively to export energy directly from a BES generating unit or generating plant; except that Elements may also supply generating plant loads.
 - 4.2.5. Elements utilized in the aggregation of dispersed power producing resources.

5. Effective Date: See Implementation Plan

¹ Relays include low voltage protection devices that have adjustable settings.

² These transformers are variably referred to as station power, unit auxiliary transformer(s) (UAT), or station service transformer(s) used to provide overall auxiliary power to the generator station when the generator is running. Loss of these transformers will result in removing the generator from service. Refer to the PRC-025-12 Guidelines and Technical Basis for more detailed information concerning unit auxiliary transformers.

PRC-025-12— Generator Relay Loadability

5-6. Background: After analysis of many of the major disturbances in the last 25 years on the North American interconnected power system, generators have been found to have tripped for conditions that did not apparently pose a direct risk to those generators and associated equipment within the time period where the tripping occurred. This tripping has often been determined to have expanded the scope and/or extended the duration of that disturbance. This was noted to be a serious issue in the August 2003 “blackout” in the northeastern North American continent.³

During the recoverable phase of a disturbance, the disturbance may exhibit a “voltage disturbance” behavior pattern, where system voltage may be widely depressed and may fluctuate. In order to support the system during this transient phase of a disturbance, this standard establishes criteria for setting load-responsive protective relays such that individual generators may provide Reactive Power within their dynamic capability during transient time periods to help the system recover from the voltage disturbance. The premature or unnecessary tripping of generators resulting in the removal of dynamic Reactive Power exacerbates the severity of the voltage disturbance, and as a result changes the character of the system disturbance. In addition, the loss of Real Power could initiate or exacerbate a frequency disturbance.

7. Standard Only Definition: None.

6.1. Effective Date: See Implementation Plan

B. Requirements and Measures

- R1.** Each Generator Owner, Transmission Owner, and Distribution Provider shall apply settings that are in accordance with PRC-025-12 – Attachment 1: Relay Settings, on each load-responsive protective relay while maintaining reliable fault protection. *[Violation Risk Factor: High] [Time Horizon: Long-Term Planning]*
- M1.** For each load-responsive protective relay, each Generator Owner, Transmission Owner, and Distribution Provider shall have evidence (e.g., summaries of calculations, spreadsheets, simulation reports, or setting sheets) that settings were applied in accordance with PRC-025-12 – Attachment 1: Relay Settings.

C. Compliance

1. Compliance Monitoring Process

~~6.1.~~ Compliance Enforcement Authority

- 1.1.** ~~As defined in the NERC Rules of Procedure;~~ “Compliance Enforcement Authority” means NERC or the Regional Entity, or any entity as otherwise

³ ~~Interim Report~~ Interim Report; Causes of the August 14th Blackout in the United States and Canada, U.S.-Canada Power System Outage Task Force, November 2003 (<http://www.nerc.com/docs/docs/blackout/814BlackoutReport.pdf>).

PRC-025-12— Generator Relay Loadability

~~designated by an Applicable Governmental Authority~~, in their respective roles of monitoring and/or enforcing compliance with ~~the NERC mandatory and enforceable~~ Reliability Standards ~~in their respective jurisdictions~~.

- 1.2. Evidence Retention:** The following evidence retention ~~periods~~period(s) identify the period of time an entity is required to retain specific evidence to demonstrate compliance. For instances where the evidence retention period specified below is shorter than the time since the last audit, the Compliance Enforcement Authority (~~CEA~~) may ask an entity to provide other evidence to show that it was compliant for the full time period since the last audit.

The ~~Generator Owner, Transmission Owner, and Distribution Provider~~applicable entity shall keep data or evidence to show compliance as identified below unless directed by its ~~CEA~~Compliance Enforcement Authority to retain specific evidence for a longer period of time as part of an investigation:

- The Generator Owner, Transmission Owner, and Distribution Provider shall retain evidence of Requirement R1 and Measure M1 for the most recent three calendar years.
- If a Generator Owner, Transmission Owner, or Distribution Provider is found non-compliant, it shall keep information related to the non-compliance until mitigation is complete and approved or for the time specified above, whichever is longer.

~~The CEA shall keep the last audit records and all requested and submitted subsequent audit records.~~

~~6.2— Compliance Monitoring and Assessment Processes~~

~~Compliance Audit~~

~~Self-Certification~~

~~Spot Checking~~

~~Compliance Investigation~~

~~Self-Reporting~~

~~Complaint~~

~~6.3— Additional Compliance Information~~

~~None~~

PRC-025-12— Generator Relay Loadability

Table of Compliance Elements

Violation Severity Levels

R #	Time Horizon	VRF	Violation Severity Levels			
			Lower VSL	Moderate VSL	High VSL	Severe VSL
R1	Long-Term Planning	High	N/A	N/A	N/A	The Generator Owner, Transmission Owner, and Distribution Provider did not apply settings in accordance with PRC-025-42 – Attachment 1: Relay Settings, on an applied load-responsive protective relay.

Deleted Cells
Deleted Cells

D. Regional Variances

None.

E. Interpretations

None.

F. Associated Documents

NERC System Protection and Control Subcommittee, [July 2010, ““Considerations for Power Plant and Transmission System Protection Coordination” technical reference document, Revision 2. \(Date of Publication: July 2015\)](#)

[NERC System Protection and Control Subcommittee, “Unit Auxiliary Transformer Overcurrent Relay Loadability During a Transmission Depressed Voltage Condition.” \(Date of Publication: March 2016\)](#)

IEEE C37.102-2006, [“IEEE Guide for AC Generator Protection.” \(Date of Publication: 2006\)](#)

[IEEE C37.17-2012, “IEEE Standard for Trip Systems for Low-Voltage \(1000 V and below\) AC and General Purpose \(1500 V and below\) DC Power Circuit Breakers.” \(Date of Publication: September 18, 2012\)](#)

[IEEE C37.2-2008, “IEEE Standard for Electrical Power System Device Function Numbers, Acronyms, and Contact Designations.” \(Date of Publication: October 3, 2008\)](#)

Version History

Version	Date	Action	Change Tracking
1	August 15, 2013	Adopted by NERC Board of Trustees	New
1	July 17, 2014	FERC order issued approving PRC-025-1	
<u>2</u>	<u>April 19, 2017</u>	<u>Standards Committee acceptance of the Standards Authorization Request</u>	<u>Project 2016-04</u>
<u>2</u>	<u>TBD</u>	<u>Adopted by NERC Board of Trustees</u>	<u>Revised</u>
<u>2</u>	<u>TBD</u>	<u>FERC order issued approving PRC-025-2</u>	

PRC-025-2 – Attachment 1: Relay Settings

Introduction

This standard does not require the Generator Owner, Transmission Owner, or Distribution Provider to use any of the protective functions listed in Table 1. Each Generator Owner, Transmission Owner, and Distribution Provider that applies load-responsive protective relays on their respective Elements listed in 34.2, Facilities, shall use one of the following Options in Table 1, Relay Loadability Evaluation Criteria (“Table 1”), to set each load-responsive protective relay element according to its application and relay type. The bus voltage is based on the criteria for the various applications listed in Table 1.

Generators

Synchronous generator relay ~~pickup~~ setting criteria values are derived from the unit’s maximum gross Real Power capability, in megawatts (MW), as reported to the Transmission Planner, and the unit’s Reactive Power capability, in megavoltampere-reactive (Mvar), is determined by calculating the MW value based on the unit’s nameplate megavoltampere (MVA) rating at rated power factor. If different seasonal capabilities are reported, the maximum capability shall be used for the purposes of this standard as a minimum requirement. The Generator Owner may base settings on a capability that is higher than what is reported to the Transmission Planner.

Asynchronous generator relay ~~pickup~~ setting criteria values (including inverter-based installations) are derived from the site’s aggregate maximum complex power capability, in MVA, as reported to the Transmission Planner, including the Mvar output of any static or dynamic reactive power devices. If different seasonal capabilities are reported, the maximum capability shall be used for the purposes of this standard as a minimum requirement. The Generator Owner may base settings on a capability that is higher than what is reported to the Transmission Planner.

For ~~the application case~~applications where synchronous and asynchronous generator types are combined on a generator step-up transformer or on Elements that connect the generator step-up (GSU) transformer(s) to the Transmission system that are used exclusively to export energy directly from a BES generating unit or generating plant (except that Elements may also supply generating plant loads~~),~~ the ~~pickup~~ setting criteria shall be determined by vector summing the ~~pickup~~ setting criteria of each generator type, and using the bus voltage for the given synchronous generator application and relay type.

Transformers

Calculations using the GSU transformer turns ratio shall use the actual tap that is applied (i.e., in service) for GSU transformers with ~~deenergized~~de-energized tap changers (DETC). If load tap changers (LTC) are used, the calculations shall reflect the tap that results in the lowest generator bus voltage. When the criterion specifies the use of the GSU transformer’s impedance, the nameplate impedance at the nominal GSU transformer turns ratio shall be used.

Applications that use more complex topology, such as generators connected to a multiple winding transformer, are not directly addressed by the criteria in Table 1. These topologies can

PRC-025-12— Generator Relay Loadability

result in complex power flows, and may require simulation to avoid overly conservative assumptions to simplify the calculations. Entities with these topologies should set their relays in such a way that they do not operate for the conditions being addressed in this standard.

Multiple Lines

Applications that use more complex topology, such as multiple lines that connect the generator step-up (GSU) transformer(s) to the Transmission system that are used exclusively to export energy directly from a BES generating unit or generating plant ([except that](#) Elements may also supply generating plant loads) are not directly addressed by the criteria in Table 1. These topologies can result in complex power flows, and it may require simulation to avoid overly conservative assumptions to simplify the calculations. Entities with these topologies should set their relays in such a way that they do not operate for the conditions being addressed in this standard.

Exclusions

The following protection systems are excluded from the requirements of this standard:

1. Any relay elements that are in service only during start up.
2. Load-responsive protective relay elements that are armed only when the generator is disconnected from the system, (e.g., non-directional overcurrent elements used in conjunction with inadvertent energization schemes, and open breaker flashover schemes).
3. Phase fault detector relay elements employed to supervise other load-responsive phase distance elements (e.g., in order to prevent false operation in the event of a loss of potential) provided the distance element is set in accordance with the criteria outlined in the standard.
4. Protective relay elements that are only enabled when other protection elements fail (e.g., overcurrent elements that are only enabled during loss of potential conditions).
5. Protective relay elements used only for ~~Special Protection Systems~~[Remedial Action Schemes](#) that are subject to one or more requirements in a NERC or Regional Reliability Standard.
6. Protection systems that detect generator overloads that are designed to coordinate with the generator short time capability by utilizing an extremely inverse characteristic set to operate no faster than 7 seconds at 218% of ~~full load~~[full load](#) current (e.g., rated armature current), and prevent operation below 115% of full-load current.⁴
7. Protection systems that detect ~~transformer~~ overloads and are designed only to respond in time periods which allow an operator 15 minutes or greater to respond to overload conditions.
8. [Low voltage protection devices that do not have adjustable settings.](#)

Table 1

Table 1 ~~beginning on the next page~~[below](#) is structured and formatted to aid the reader with identifying an option for a given load-responsive protective relay.

⁴ IEEE C37.102-2006, "Guide for AC Generator Protection," Section 4.1.1.2.

PRC-025-12— Generator Relay Loadability

The first column identifies the application (e.g., synchronous or asynchronous generators, generator step-up transformers, unit auxiliary transformers, Elements that connect the GSU transformer(s) to the Transmission system that are used exclusively to export energy directly from a BES generating unit or generating plant. ~~Elements may also supply generating plant loads~~). Dark blue horizontal bars, excluding the header which repeats at the top of each page, demarcate the various applications.

The second column identifies the load-responsive [distance or overcurrent](#) protective relay [by IEEE device numbers](#) (e.g., 21, 50, 51, 51V-C, 51V-R, or 67) according to the ~~applied~~ application in the first column. [This also includes manufacture protective device trip unit designations for long-time delay, short-time delay, and instantaneous \(e.g., L, S, and I\)](#). A light blue horizontal bar between the relay types is the demarcation between relay types for a given application. These light blue bars will contain no text, [except when the same application continues on the next page of the table with a different relay type](#).

The third column uses numeric and alphabetic options (i.e., index numbering) to identify the available options for setting load-responsive protective relays according to the application and applied relay type. Another, shorter, light blue bar contains the word “OR,” and reveals to the reader that the relay for that application has one or more options (i.e., “ways”) to determine the bus voltage and ~~pickup~~ setting criteria in the fourth and fifth column, respectively. The bus voltage column and ~~pickup~~ setting criteria columns provide the criteria for determining an appropriate setting.

The table is further formatted by shading groups of relays associated with asynchronous generator applications. Synchronous generator applications and the unit auxiliary transformer applications are not shaded. Also, intentional buffers were added to the table such that similar options, as possible, would be paired together on a per page basis. Note that some applications may have an additional pairing that might occur on adjacent pages.

Table 1. Relay Loadability Evaluation Criteria					
Application	Relay Type	Option	Bus Voltage ⁵	Pickup Setting Criteria	
Synchronous generating unit(s), or including Elements utilized in the aggregation of dispersed power producing resources	Phase distance relay (e.g., 21) – directional toward the Transmission system	1a	Generator bus voltage corresponding to 0.95 per unit of the high-side nominal voltage times the turns ratio of the generator step-up transformer	The impedance element shall be set less than the calculated impedance derived from 115% of: (1) Real Power output – 100% of the gross MW capability reported to the Transmission Planner, and (2) Reactive Power output – 150% of the MW value, derived from the generator nameplate MVA rating at rated power factor	
		OR			
		1b	Calculated generator bus voltage corresponding to 0.85 per unit nominal voltage on the high-side terminals of the generator step-up transformer (including the transformer turns ratio and impedance)	The impedance element shall be set less than the calculated impedance derived from 115% of: (1) Real Power output – 100% of the gross MW capability reported to the Transmission Planner, and (2) Reactive Power output – 150% of the MW value, derived from the generator nameplate MVA rating at rated power factor	
		OR			
		1c	Simulated generator bus voltage coincident with the highest Reactive Power output achieved during field-forcing in response to a 0.85 per unit nominal voltage on the high-side terminals of the generator step-up transformer prior to field-forcing	The impedance element shall be set less than the calculated impedance derived from 115% of: (1) Real Power output – 100% of the gross MW capability reported to the Transmission Planner, and (2) Reactive Power output –100% of the maximum gross Mvar output during field-forcing as determined by simulation	
The same application continues on the next page with a different relay type					

⁵ Calculations using the generator step-up (GSU) transformer turns ratio shall use the actual tap that is applied (i.e., in service) for GSU transformers with ~~deenergized~~energized tap changers (DETC). If load tap changers (LTC) are used, the calculations shall reflect the tap that results in the lowest generator bus voltage. When the criterion specifies the use of the GSU transformer’s impedance, the nameplate impedance at the nominal GSU turns ratio shall be used.

Table 1. Relay Loadability Evaluation Criteria						
Application	Relay Type	Option	Bus Voltage ⁵	Pickup Setting Criteria		
Synchronous generating unit(s), including Elements utilized in the aggregation of dispersed power producing resources	Phase time overcurrent relay (e.g., 50, 51), or (51V-R) – voltage-restrained	2a	Generator bus voltage corresponding to 0.95 per unit of the high-side nominal voltage times the turns ratio of the generator step-up transformer	The overcurrent element shall be set greater than 115% of the calculated current derived from: (1) Real Power output – 100% of the gross MW capability reported to the Transmission Planner, and (2) Reactive Power output – 150% of the MW value, derived from the generator nameplate MVA rating at rated power factor		
		OR				
		2b	Calculated generator bus voltage corresponding to 0.85 per unit nominal voltage on the high-side terminals of the generator step-up transformer (including the transformer turns ratio and impedance)	The overcurrent element shall be set greater than 115% of the calculated current derived from: (1) Real Power output – 100% of the gross MW capability reported to the Transmission Planner, and (2) Reactive Power output – 150% of the MW value, derived from the generator nameplate MVA rating at rated power factor		
	OR					
		2c	Simulated generator bus voltage coincident with the highest Reactive Power output achieved during field-forcing in response to a 0.85 per unit nominal voltage on the high-side terminals of the generator step-up transformer prior to field-forcing	The overcurrent element shall be set greater than 115% of the calculated current derived from: (1) Real Power output – 100% of the gross MW capability reported to the Transmission Planner or, and (2) Reactive Power output –100% of the maximum gross Mvar output during field-forcing as determined by simulation		
<i>The same application continues with a different relay type below</i>						
	Phase time overcurrent relay (e.g., 51V-C) – voltage controlled (Enabled to operate as a function of voltage)	3	Generator bus voltage corresponding to 1.0 per unit of the high-side nominal voltage times the turns ratio of the generator step-up transformer	Voltage control setting shall be set less than 75% of the calculated generator bus voltage		
A different application starts on the next page						

PRC-025-12— Generator Relay Loadability

Table 1. Relay Loadability Evaluation Criteria				
Application	Relay Type	Option	Bus Voltage ⁵	Pickup Setting Criteria
Asynchronous generating unit(s) (including inverter-based installations), including Elements utilized in the aggregation of dispersed power producing resources	Phase distance relay (e.g., 21) – directional toward the Transmission system	4	Generator bus voltage corresponding to 1.0 per unit of the high-side nominal voltage times the turns ratio of the generator step-up transformer	The impedance element shall be set less than the calculated impedance derived from 130% of the maximum aggregate nameplate MVA output at rated power factor (including the Mvar output of any static or dynamic reactive power devices)
	Phase time overcurrent relay (e.g., 50, 51), or (51V-R) – voltage-restrained	5a	Generator bus voltage corresponding to 1.0 per unit of the high-side nominal voltage times the turns ratio of the generator step-up transformer	The overcurrent element shall be set greater than 130% of the calculated current derived from the maximum aggregate nameplate MVA output at rated power factor (including the Mvar output of any static or dynamic reactive power devices)
		OR		
		5b	Generator bus voltage corresponding to 1.0 per unit of the high-side nominal voltage times the turns ratio of the generator step-up transformer	The lower tolerance of the overcurrent element tripping characteristic shall not infringe upon the resource capability (including the Mvar output of the resource and any static or dynamic reactive power devices) See Figure A.
	Phase time overcurrent relay (e.g., 51V-C) – voltage controlled (Enabled to operate as a function of voltage)	6	Generator bus voltage corresponding to 1.0 per unit of the high-side nominal voltage times the turns ratio of the generator step-up transformer	Voltage control setting shall be set less than 75% of the calculated generator bus voltage
A different application starts on the next page				
	Phase distance relay (e.g., 21) – directional toward the Transmission system – installed on generator side	7a	Generator bus voltage corresponding to 0.95 per unit of the high-side nominal voltage times the turns ratio of the generator step-up transformer	The impedance element shall be set less than the calculated impedance derived from 115% of: (1) Real Power output – 100% of the aggregate generation gross MW reported to the Transmission Planner, and (2) Reactive Power output – 150% of the aggregate generation MW value, derived from the generator nameplate MVA rating at rated power factor

Merged Cells

Inserted Cells

PRC-025-12— Generator Relay Loadability

Table 1. Relay Loadability Evaluation Criteria				
Application	Relay Type	Option	Bus Voltage ⁵	Pickup Setting Criteria
<u>Relays installed on generator-side⁶ of the</u> Generator step-up transformer(s) connected to synchronous generators	of the GSU transformer If the relay is installed on the high-side of the GSU transformer use Option 14	OR		
		7b	Calculated generator bus voltage corresponding to 0.85 per unit nominal voltage on the high-side terminals of the generator step-up transformer (including the transformer turns ratio and impedance)	The impedance element shall be set less than the calculated impedance derived from 115% of: (1) Real Power output – 100% of the aggregate generation gross MW reported to the Transmission Planner, and (2) Reactive Power output – 150% of the aggregate generation MW value, derived from the generator nameplate MVA rating at rated power factor
		OR		
		7c	Simulated generator bus voltage coincident with the highest Reactive Power output achieved during field-forcing in response to 0.85 per unit nominal voltage on the high-side terminals of the generator step-up transformer prior to field-forcing	The impedance element shall be set less than the calculated impedance derived from 115% of: (1) Real Power output – 100% of the aggregate generation gross MW reported to the Transmission Planner, and (2) Reactive Power output –100% of the aggregate generation maximum gross Mvar output during field-forcing as determined by simulation
The same application continues on the next page with a different relay type				
<u>Relays installed on generator-side⁷ of the</u> Generator step-up transformer(s) connected to synchronous generators	Phase time overcurrent relay (e.g., 50 or 51) – installed on generator-side of the GSU transformer	8a	Generator bus voltage corresponding to 0.95 per unit of the high-side nominal voltage times the turns ratio of the generator step-up transformer	The overcurrent element shall be set greater than 115% of the calculated current derived from: (1) Real Power output – 100% of the aggregate generation gross MW reported to the Transmission Planner, and (2) Reactive Power output – 150% of the aggregate generation MW value, derived from the generator nameplate MVA rating at rated power factor
		OR		

⁶ If the relay is installed on the high-side of the GSU transformer, use Option 14.

⁷ If the relay is installed on the high-side of the GSU transformer use, Option 15.

PRC-025-12— Generator Relay Loadability

Table 1. Relay Loadability Evaluation Criteria					
Application	Relay Type	Option	Bus Voltage ⁵	Pickup Setting Criteria	
	If the relay is installed on the high-side of the GSU transformer use Option 15	8b	Calculated generator bus voltage corresponding to 0.85 per unit nominal voltage on the high-side terminals of the generator step-up transformer (including the transformer turns ratio and impedance)	The overcurrent element shall be set greater than 115% of the calculated current derived from: (1) Real Power output – 100% of the aggregate generation gross MW reported to the Transmission Planner, and (2) Reactive Power output – 150% of the aggregate generation MW value, derived from the generator nameplate MVA rating at rated power factor	
		OR			
		8c	Simulated generator bus voltage coincident with the highest Reactive Power output achieved during field-forcing in response to a 0.85 per unit nominal voltage on the high-side terminals of the generator step-up transformer prior to field-forcing	The overcurrent element shall be set greater than 115% of the calculated current derived from: (1) Real Power output – 100% of the aggregate generation gross MW reported to the Transmission Planner, and (2) Reactive Power output –100% of the aggregate generation maximum gross Mvar output during field-forcing as determined by simulation	
The same application continues on the next page with a different relay type					
<u>Relays installed on generator-side⁸ of the</u> Generator step-up transformer(s) connected to synchronous generators	Phase directional time -overcurrent relay (e.g., 67) – directional toward the Transmission system —installed on-generator-side	9a	Generator bus voltage corresponding to 0.95 per unit of the high-side nominal voltage times the turns ratio of the generator step-up transformer	The overcurrent element shall be set greater than 115% of the calculated current derived from: (1) Real Power output – 100% of the aggregate generation gross MW reported to the Transmission Planner, and (2) Reactive Power output – 150% of the aggregate generation MW value, derived from the generator nameplate MVA rating at rated power factor	
		OR			

⁸ If the relay is installed on the high-side of the GSU transformer use, Option 16.

Table 1. Relay Loadability Evaluation Criteria					
Application	Relay Type	Option	Bus Voltage ⁵	Pickup Setting Criteria	
	of the GSU transformer If the relay is installed on the high side of the GSU transformer use Option 16	9b	Calculated generator bus voltage corresponding to 0.85 per unit nominal voltage on the high-side terminals of the generator step-up transformer (including the transformer turns ratio and impedance)	The overcurrent element shall be set greater than 115% of the calculated current derived from: (1) Real Power output – 100% of the aggregate generation gross MW reported to the Transmission Planner, and (2) Reactive Power output – 150% of the aggregate generation MW value, derived from the generator nameplate MVA rating at rated power factor	
		OR			
		9c	Simulated generator bus voltage coincident with the highest Reactive Power output achieved during field-forcing in response to a 0.85 per unit nominal voltage on the high-side terminals of the generator step-up transformer prior to field-forcing	The overcurrent element shall be set greater than 115% of the calculated current derived from: (1) Real Power output – 100% of the aggregate generation gross MW reported to the Transmission Planner, and (2) Reactive Power output – 100% of the aggregate generation maximum gross Mvar output during field-forcing as determined by simulation	
A different application starts on the next page					

PRC-025-12— Generator Relay Loadability

Table 1. Relay Loadability Evaluation Criteria				
Application	Relay Type	Option	Bus Voltage ⁵	Pickup Setting Criteria
Relays installed on generator-side of the Generator step-up transformer(s) connected to asynchronous generators only (including inverter-based installations)	Phase distance relay (e.g., 21) – directional toward the Transmission system— installed on generator-side of the GSU transformer	10	Generator bus voltage corresponding to 1.0 per unit of the high-side nominal voltage times the turns ratio of the generator step-up transformer	The impedance element shall be set less than the calculated impedance derived from 130% of the maximum aggregate nameplate MVA output at rated power factor (including the Mvar output of any static or dynamic reactive power devices)
	If the relay is installed on the high-side of the GSU transformer use Option 17 ⁹			
	Phase time overcurrent relay (e.g., 50 or 51)— installed on generator-side of the GSU transformer	11	Generator bus voltage corresponding to 1.0 per unit of the high-side nominal voltage times the turns ratio of the generator step-up transformer for overcurrent relays installed on the low-side	The overcurrent element shall be set greater than 130% of the calculated current derived from the maximum aggregate nameplate MVA output at rated power factor (including the Mvar output of any static or dynamic reactive power devices)
If the relay is installed on the high-side of the GSU transformer use Option 18 ¹⁰				
The same application continues on the next page with a different relay type				

⁹ If the relay is installed on the high-side of the GSU transformer, use Option 17.

¹⁰ If the relay is installed on the high-side of the GSU transformer, use Option 18.

PRC-025-12— Generator Relay Loadability

Table 1. Relay Loadability Evaluation Criteria

Application	Relay Type	Option	Bus Voltage ⁵	Pickup Setting Criteria
Generator step-up transformer(s) connected to asynchronous generators only (including inverter-based installations)	Phase directional time -overcurrent relay (e.g., 67) – directional toward the Transmission system—installed on generator side of the GSU transformer If the relay is installed on the high-side of the GSU transformer use Option 19 ¹¹	12	Generator bus voltage corresponding to 1.0 per unit of the high-side nominal voltage times the turns ratio of the generator step-up transformer	The overcurrent element shall be set greater than 130% of the calculated current derived from the maximum aggregate nameplate MVA output at rated power factor (including the Mvar output of any static or dynamic reactive power devices)
A different application starts below on the next page				
Unit auxiliary transformer(s) (UAT)	Phase time overcurrent relay (e.g., 50 or 51) applied at the high-	13a OR	1.0 per unit of the winding nominal voltage of the unit auxiliary transformer	The overcurrent element shall be set greater than 150% of the calculated current derived from the unit auxiliary transformer maximum nameplate MVA rating

Merged Cells

¹¹ If the relay is installed on the high-side of the GSU transformer, use Option 19.

PRC-025-12— Generator Relay Loadability

Table 1. Relay Loadability Evaluation Criteria					
Application	Relay Type	Option	Bus Voltage ⁵	Pickup Setting Criteria	
	side terminals of the UAT, for which operation of the relay will cause the associated generator to trip.	13b	Unit auxiliary transformer bus voltage corresponding to the measured current	The overcurrent element shall be set greater than 150% of the unit auxiliary transformer measured current at the generator maximum gross MW capability reported to the Transmission Planner	
A different application starts on the next page					
A different application starts on the next page					
<u>Relays installed on the high-side of the GSU transformer,¹² including relays installed on the remote end of line, for</u> Elements that connect the GSU transformer(s) to the Transmission system that are used exclusively to export energy directly from a BES generating unit or generating plant: <u>(except that</u> Elements may also supply generating plant loads: <u>–)</u> – connected to synchronous generators	Phase distance relay (e.g., 21) – directional toward the Transmission system— installed on the high-side of the GSU transformer If the relay is installed on the generator side of the GSU transformer use Option 7	14a	0.85 per unit of the line nominal voltage <u>at the relay location</u>	The impedance element shall be set less than the calculated impedance derived from 115% of: (1) Real Power output – 100% of the aggregate generation gross MW reported to the Transmission Planner, and (2) Reactive Power output – 120% of the aggregate generation MW value, derived from the generator nameplate MVA rating at rated power factor	
		OR			
		14b	Simulated line voltage <u>at the relay location</u> coincident with the highest Reactive Power output achieved during field-forcing in response to a 0.85 per unit <u>of the line</u> nominal voltage on <u>at the high-side terminals</u> remote end <u>of the generator step-up transformer</u> line prior to field-forcing	The impedance element shall be set less than the calculated impedance derived from 115% of: (1) Real Power output – 100% of the aggregate generation gross MW reported to the Transmission Planner, and (2) Reactive Power output –100% of the aggregate generation maximum gross Mvar output during field-forcing as determined by simulation	
The same application continues on the next page with a different relay type					

¹² If the relay is installed on the generator-side of the GSU transformer, use Option 7.

PRC-025-12— Generator Relay Loadability

Table 1. Relay Loadability Evaluation Criteria				
Application	Relay Type	Option	Bus Voltage ⁵	Pickup Setting Criteria
<p><u>Relays installed on the high-side of the GSU transformer,¹³ including relays installed at the remote end of the line, for</u> Elements that connect the GSU transformer(s) to the Transmission system that are used exclusively to export energy directly from a BES generating unit or generating plant: <u>(except that</u> Elements may also supply generating plant loads: <u>–)</u> – connected to synchronous generators</p>	<p>Phase <u>instantaneous</u> overcurrent supervisory element (e.g., 50) – associated with current-based, communication-assisted schemes where the scheme is capable of tripping for loss of communications <u>installed on the high-side of the GSU transformer and/or</u> phase time overcurrent relay (e.g., 51) – <u>installed on the high-side of the GSU transformer</u></p> <p>If the relay is installed on the generator-side of the GSU transformer use Option 8</p>	15a	0.85 per unit of the line nominal voltage <u>at the relay location</u>	The overcurrent element shall be set greater than 115% of the calculated current derived from: (1) Real Power output – 100% of the aggregate generation gross MW reported to the Transmission Planner, and (2) Reactive Power output – 120% of the aggregate generation MW value, derived from the generator nameplate MVA rating at rated power factor
		OR		
		15b	Simulated line voltage <u>at the relay location</u> coincident with the highest Reactive Power output achieved during field-forcing in response to a 0.85 per unit <u>of the line</u> nominal voltage <u>on</u> at the <u>high-side terminals</u> <u>remote end</u> of the <u>generator step-up transformer</u> <u>line</u> prior to field-forcing	The overcurrent element shall be set greater than 115% of the calculated current derived from: (1) Real Power output – 100% of the aggregate generation gross MW reported to the Transmission Planner, and (2) Reactive Power output –100% of the aggregate generation maximum gross Mvar output during field-forcing as determined by simulation

¹³ If the relay is installed on the generator-side of the GSU transformer, use Option 8.

PRC-025-12— Generator Relay Loadability

Table 1. Relay Loadability Evaluation Criteria				
Application	Relay Type	Option	Bus Voltage ⁵	Pickup Setting Criteria
The same application continues on the next page with a different relay type				
<u>Relays installed on the high-side of the GSU transformer,¹⁴ including relays installed at the remote end of the line, for</u> Elements that connect the GSU transformer(s) to the	Phase directional <u>instantaneous</u> overcurrent supervisory element (e.g., 67) – associated with current-based,	16a	0.85 per unit of the line nominal voltage <u>at the relay location</u>	The overcurrent element shall be set greater than 115% of the calculated current derived from: (1) Real Power output – 100% of the aggregate generation gross MW reported to the Transmission Planner, and (2) Reactive Power output – 120% of the aggregate generation MW value, derived from the generator nameplate MVA rating at rated power factor
		OR		

¹⁴ If the relay is installed on the generator-side of the GSU transformer, use Option 9.

Table 1. Relay Loadability Evaluation Criteria

Application	Relay Type	Option	Bus Voltage ⁵	Pickup Setting Criteria
Transmission system that are used exclusively to export energy directly from a BES generating unit or generating plant- (except that Elements may also supply generating plant load-) connected to synchronous generators	communication-assisted schemes where the scheme is capable of tripping for loss of communications directional toward the Transmission system installed on the high-side of the GSU transformer and/or phase directional time overcurrent relay (e.g., 67) – directional toward the Transmission system installed on the high-side of the GSU transformer If the relay is installed on the generator side of the GSU transformer use Option 9	16b	Simulated line voltage <u>at the relay location</u> coincident with the highest Reactive Power output achieved during field-forcing in response to a 0.85 per unit <u>of the line</u> nominal voltage on <u>at the high-side terminal remote end of the generator step-up transformer line</u> prior to field-forcing	The overcurrent element shall be set greater than 115% of the calculated current derived from: (1) Real Power output – 100% of the aggregate generation gross MW reported to the Transmission Planner, and (2) Reactive Power output –100% of the aggregate generation maximum gross Mvar output during field-forcing as determined by simulation

A different application starts on the next page

Table 1. Relay Loadability Evaluation Criteria

Application	Relay Type	Option	Bus Voltage ⁵	Pickup Setting Criteria
A different application starts on the next page				
<p><u>Relays installed on the high-side of the GSU transformer,¹⁵ including relays installed on the remote end of line, for</u> Elements that connect the GSU transformer(s) to the Transmission system that are used exclusively to export energy directly from a BES generating unit or generating plant- <u>(except that</u> Elements may also supply</p>	<p>Phase distance relay (e.g., 21) – directional toward the Transmission system – <u>installed on the high side of the GSU transformer</u></p> <p><u>If the relay is installed on the generator-side of the GSU transformer use Option 10</u></p>	17	1.0 per unit of the line nominal voltage <u>at the relay location</u>	The impedance element shall be set less than the calculated impedance derived from 130% of the maximum aggregate nameplate MVA output at rated power factor (including the Mvar output of any static or dynamic reactive power devices)

¹⁵ If the relay is installed on the generator-side of the GSU transformer, use Option 10.

Application	Relay Type	Option	Bus Voltage ⁵	Pickup Setting Criteria
generating plant loads— connected to asynchronous generators only (including inverter- based installations)	The same application continues on the next page with a different relay type			

Table 1. Relay Loadability Evaluation Criteria				
Application	Relay Type	Option	Bus Voltage ⁵	Pickup Setting Criteria
<p><u>Relays installed on the high-side of the GSU transformer.¹⁶ including, relays installed on the remote end of the line, for</u></p> <p>Elements that connect the GSU transformer(s) to the Transmission system that are used exclusively to export energy directly from a BES generating unit or generating plant: <u>(except that</u> Elements may also supply generating plant loads.) – connected to asynchronous generators only (including inverter-based installations)</p>	<p>Phase <u>instantaneous</u> overcurrent supervisory element (e.g., 50) – associated with current-based, communication-assisted schemes where the scheme is capable of tripping for loss of communications <u>installed on the high-side of the GSU transformer</u> and/or Phase time overcurrent relay (e.g., 51) – <u>installed on the high-side of the GSU transformer</u></p>	18	1.0 per unit of the line nominal voltage <u>at the relay location</u>	The overcurrent element shall be set greater than 130% of the calculated current derived from the maximum aggregate nameplate MVA output at rated power factor (including the Mvar output of any static or dynamic reactive power devices)
	<p><u>If the relay is installed on the generator-side of the GSU transformer use Option 11</u></p>			
The same application continues on the next page with a different relay type				

¹⁶ If the relay is installed on the generator-side of the GSU transformer, use Option 11.

Table 1. Relay Loadability Evaluation Criteria				
Application	Relay Type	Option	Bus Voltage ⁵	Pickup Setting Criteria
<p><u>Relays installed on the high-side of the GSU transformer,¹⁷ including relays installed on the remote end of the line, for</u> Elements that connect the GSU transformer(s) to the Transmission system that are used exclusively to export energy directly from a BES generating unit or generating plant- <u>(except that</u> Elements may also supply generating plant loads-<u>)</u> –connected to asynchronous generators only (including inverter-based installations)</p>	<p>Phase directional <u>instantaneous</u> overcurrent supervisory element (e.g., 67) – associated with current-based, communication-assisted schemes where the scheme is capable of tripping for loss of communications directional toward the Transmission system <u>installed on the high-side of the GSU transformer and/or</u> Phase directional time overcurrent relay (e.g., 67)– <u>installed on the high-side of the GSU transformer</u></p> <p><u>If the relay is installed on the generator-side of the GSU transformer use Option 12</u></p>	19	1.0 per unit of the line nominal voltage <u>at the relay location</u>	The overcurrent element shall be set greater than 130% of the calculated current derived from the maximum aggregate nameplate MVA output at rated power factor (including the Mvar output of any static or dynamic reactive power devices)
End of Table 1				

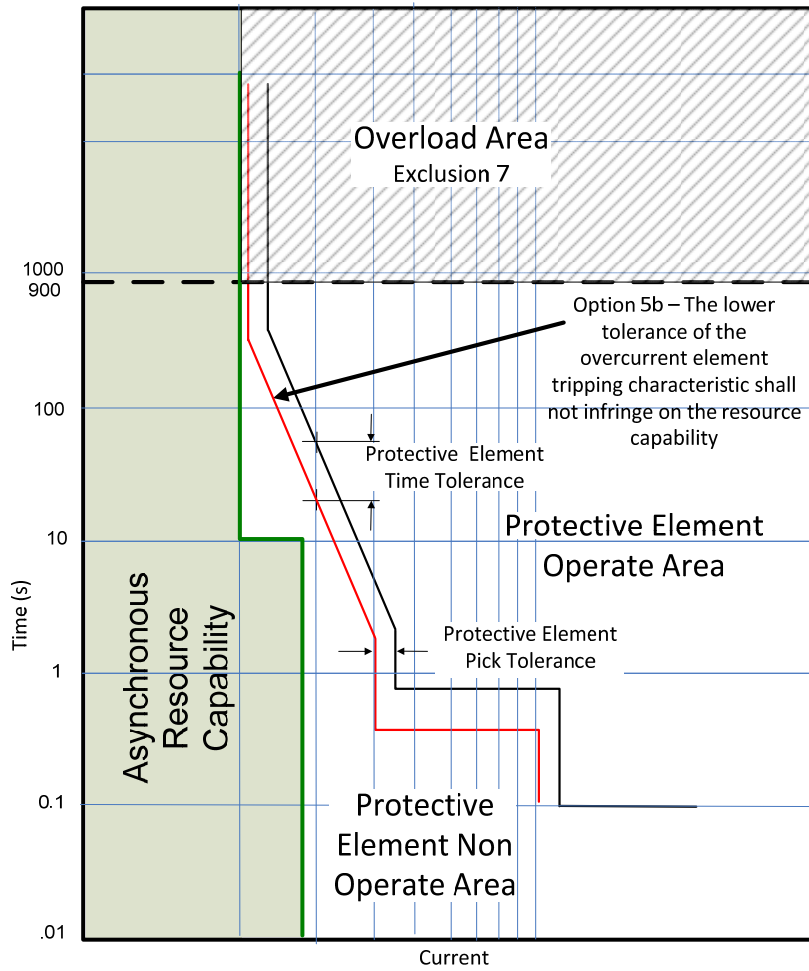

Figure A

This figure is for demonstration of Option 5b and does not mandate a specific type of protective curve or device manufacturer.

PRC-025-4~~2~~ Guidelines and Technical Basis

Introduction

The document, [“Considerations for Power Plant and Transmission System Protection Coordination”](#)~~“Power Plant and Transmission System Protection Coordination,”~~ published by the NERC System Protection and Control Subcommittee (SPCS) provides extensive general discussion about the protective functions and generator performance addressed within this standard. This document was last revised in July ~~2010~~2015.¹⁸

The basis for the standard’s loadability criteria for relays applied at the generator terminals or low-side of the generator step-up (GSU) transformer is the dynamic generating unit loading values observed during the August 14, 2003 blackout, other subsequent system events, and simulations of generating unit response to similar system conditions. The Reactive Power output observed during field-forcing in these events and simulations approaches a value equal to 150 percent of the Real Power (MW) capability of the generating unit when the generator is operating at its Real Power capability. In the SPCS technical reference document, two operating conditions were examined based on these events and simulations: (1) when the unit is operating at rated Real Power in MW with a level of Reactive Power output in Mvar which is equivalent to 150 percent times the rated MW value (representing some level of field-forcing) and (2) when the unit is operating at its declared low active Real Power operating limit (e.g., 40 percent of rated Real Power) with a level of Reactive Power output in Mvar which is equivalent to 175 percent times the rated MW value (representing some additional level of field-forcing).

Both conditions noted above are evaluated with the GSU transformer high-side voltage at 0.85 per unit. These load operating points are believed to be conservatively high levels of Reactive Power out of the generator with a 0.85 per unit high-side voltage which was based on these observations. However, for the purposes of this standard it was determined that the second load point (40 percent) offered no additional benefit and only increased the complexity for an entity to determine how to comply with the standard. Given the conservative nature of the criteria, which may not be achievable by all generating units, an alternate method is provided to determine the Reactive Power output by simulation. Also, to account for Reactive Power losses in the GSU transformer, a reduced level of output of 120 percent times the rated MW value is provided for relays applied at the high-side of the GSU transformer and on Elements that connect a GSU transformer to the Transmission system and are used exclusively to export energy directly from a BES generating unit or generating plant.

The phrase, “while maintaining reliable fault protection” in Requirement R1, describes that the Generator Owner, Transmission Owner, and Distribution Provider is to comply with this standard while achieving its desired protection goals. Load-responsive protective relays, as addressed

¹⁸

<http://www.nerc.com/docs/pe/spetf/comm/PC/System%20Protection%20and%20Control%20Subcommittee%20SPCS%20/S PCS%20 Gen%20Prot%20Coord%20Rev1%20Final%2007-30-2010%20Coordination%20Technical%20Reference%20Document.pdf>

within this standard, may be intended to provide a variety of backup protection functions, both within the generating unit or generating plant and on the Transmission system, and this standard is not intended to result in the loss of these protection functions. Instead, it is suggested that the Generator Owner, Transmission Owner, and Distribution Provider consider both the requirement within this standard and its desired protection goals, and perform modifications to its protective relays or protection philosophies as necessary to achieve both.

For example, if the intended protection purpose is to provide backup protection for a failed Transmission breaker, it may not be possible to achieve this purpose while complying with this standard if a simple mho relay is being used. In this case, it may be possible to meet this purpose by replacing the legacy relay with a modern advanced-technology relay that can be set using functions such as load encroachment. It may otherwise be necessary to reconsider whether this is an appropriate method of achieving protection for the failed Transmission breaker, and whether this protection can be better provided by, for example, applying a breaker failure relay with a transfer trip system.

Requirement R1 establishes that the Generator Owner, Transmission Owner, and Distribution Provider must understand the applications of Attachment 1: Relay Settings, Table 1: Relay Loadability Evaluation Criteria (“Table 1”) in determining the settings that it must apply to each of its load-responsive protective relays to prevent an unnecessary trip of its generator during the system conditions anticipated by this standard.

Applicability

To achieve the reliability objective of this standard it is necessary to include all load-responsive protective relays that are affected by increased generator output in response to system disturbances. This standard is therefore applicable to relays applied by the Generator Owner, Transmission Owner, and Distribution Provider at the terminals of the generator, GSU transformer, unit auxiliary transformer (UAT), Elements that connect a GSU transformer to the Transmission system that are used exclusively to export energy directly from a BES generating unit or generating plant, and Elements utilized in the aggregation of dispersed power producing resources.

The Generator Owner’s interconnection facility (in some cases labeled a “transmission Facility” or “generator leads”) consists of Elements between the GSU transformer and the interface with the portion of the Bulk Electric System (BES) where Transmission Owners take over the ownership. This standard does not use the industry recognized term “generator interconnection Facility” consistent with the work of Project 2010-07 (Generator Requirements at the Transmission Interface), because the term generator interconnection Facility implies ownership by the Generator Owner. Instead, this standard refers to these Facilities as “Elements that connect a GSU transformer to the Transmission system that are used exclusively to export energy directly from a BES generating unit or generating plant” to include these Facilities when they are also owned by the Transmission Owner or Distribution Provider. The load-responsive protective relays in this standard for which an entity shall be in compliance [isare](#) dependent on the location and the application of the protective functions. Figures 1, 2, and 3 illustrate various generator

interface connections with the Transmission system, and Figure 4 illustrates examples of Elements utilized in the aggregation of dispersed power resources that are in scope of the standard.

Figure 1

Figure 1 is a single (or set) of generators connected to the Transmission system through a radial line that is used exclusively to export energy directly from a BES generating unit or generating plant to the network. The protective relay R1 located on the high-side of the GSU transformer breaker CB100 is generally applied to provide backup protection to the relaying located at Bus A and in some cases Bus B. Under this application, relay R1 would apply the loadability requirement in PRC-025-1~~2~~ using an appropriate option for the application from Table 1 (e.g., Options 14 through 19) for Elements that connect a GSU transformer to the Transmission system that are used exclusively to export energy directly from a BES generating unit or generating plant.

The protective relay R2 located on the incoming source breaker CB102 to the generating plant applies relaying that primarily protects the line by using line differential relaying from Bus A to B and also provides backup protection to the transmission relaying at Bus B. In this case, the relay function that provides line protection would apply the loadability requirement in PRC-025-1~~2~~ and an appropriate option for the application from Table 1 (e.g., 15a, 15b, 16a, 16b, 18, and 19) for phase overcurrent supervisory elements (i.e., phase fault detectors) associated with current-based, communication-assisted schemes (i.e., pilot wire, phase comparison, and line current differential) where the scheme is capable of tripping for loss of communications. The backup protective function would apply the requirement in the PRC-025-1~~2~~ standard using an appropriate option for the application from Table 1 (e.g., Options 14 through 19) for Elements that connect a GSU transformer to the Transmission system that are used exclusively to export energy directly from a BES generating unit or generating plant.

~~In this particular case,~~

~~Since Elements that connect the GSU transformer(s) to the Transmission system that are used exclusively to export energy directly from a BES generating unit or generating plant are applicable responsible entity's to the standard, the loadability for relays applied on these Elements as shown in the shaded area of Figure 1 (i.e., CB102 and CB103) must be considered. If relay R2 or R3 is set with an element directional relay R3 located on breaker CB103 at Bus B looking toward Bus A (i.e., generation plant) is not included in either loadability standard (i.e., PRC-023 or PRC-025) since it is not the transmission system (e.g., Buses B, C and D) or are non-directional, the relay would be affected by increased generator output in response to system disturbances and must meet the loadability setting criteria described in this standard or. If relay R2 or R3 is set with an element directional toward the generator (e.g., Bus A), the relay would not be affected by increased transmission system loading generator output in response to system disturbances; therefore, the entity would not be required to apply the loadability setting criteria described in PRC-023. Any protective element set to protect in the direction from Bus A to B is included within the PRC-025-1 this standard. PRC-025-1 is applicable to Relay R3, for example, if the relay is applied and set to trip for a reverse element directional toward the Transmission system.~~

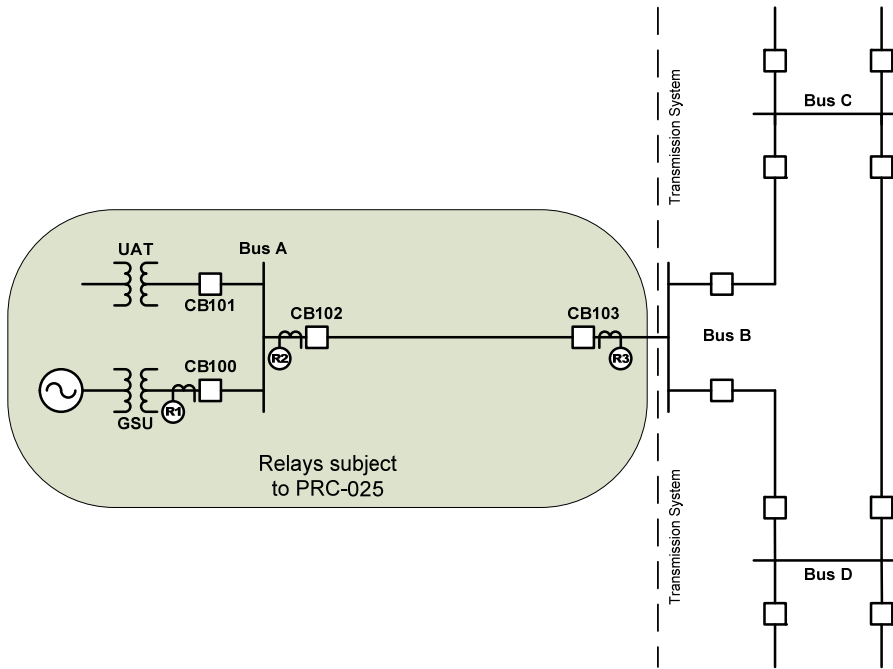

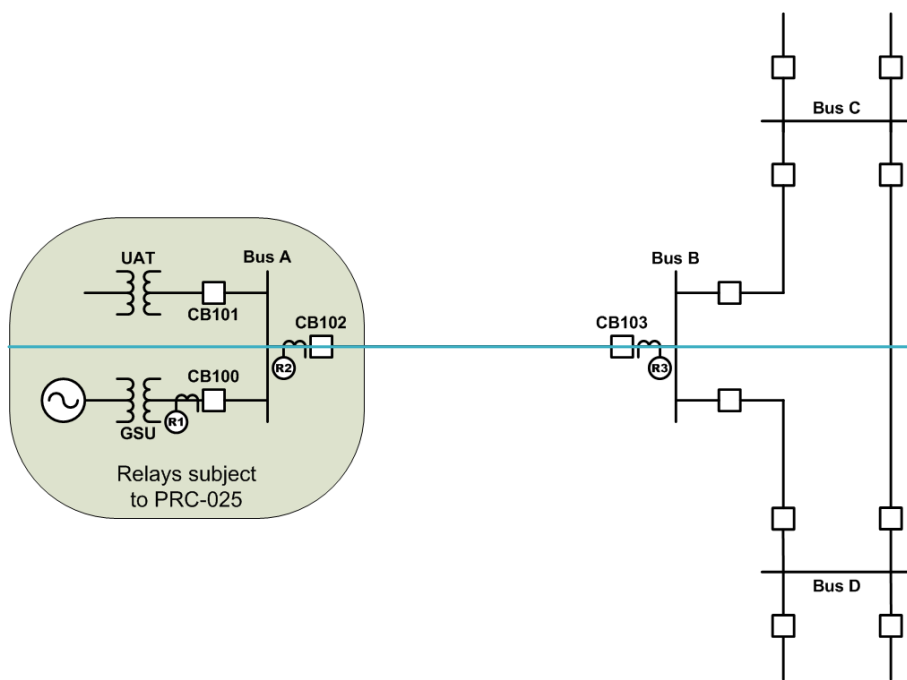

Figure 1: Generation exported through a single radial line.

Figure 2

Figure 2 is an example of a single (or set) of generators connected to the Transmission system through multiple lines that are used exclusively to export energy directly from a BES generating unit or generating plant to the network. The protective relay R1 on the high-side of the GSU transformer breaker CB100 is generally applied to provide backup protection to the Transmission relaying located at Bus A and in some cases Bus B. Under this application, relay R1 would apply the loadability requirement in PRC-025-12 using an appropriate option for the application from Table 1 (e.g., Options 14 through 19) for Elements that connect a GSU transformer to the Transmission system that are used exclusively to export energy directly from a BES generating unit or generating plant.

The protective relays R2 and R3 located on the incoming source breakers CB102 and CB103 to the generating plant applies relaying that primarily protects the line from Bus A to B and also provides backup protection to the transmission relaying at Bus B. In this case, the relay function that provides line protection would apply the loadability requirement in PRC-025-12 and an appropriate option for the application from Table 1 (e.g., Options 15a, 15b, 16a, 16b, 18, and 19) for phase overcurrent supervisory elements (i.e., phase fault detectors) associated with current-based, communication-assisted schemes (i.e., pilot wire, phase comparison, and line current

differential) where the scheme is capable of tripping for loss of communications. The backup protective function would apply the requirement in the PRC-025-~~1~~2 standard using an appropriate option for the application from Table 1 (e.g., Options 14 through 19) for Elements that connect a GSU transformer to the Transmission system that are used exclusively to export energy directly from a BES generating unit or generating plant.

~~In this particular case, the applicable responsible entity's directional relay R4 and R5 located on the breakers CB104 and CB105, respectively at Bus B looking into the generation plant are not included in either loadability standard (i.e., PRC-023 or PRC-025) since they are not subject to the stressed loading requirements described in the standard or by increased transmission system loading described in PRC-023. Any protective element set to protect in the direction from Bus A to B is included within the PRC-025-1 standard. PRC-025-1 is applicable to Relay R4 and R5; for example, if the relays are applied and set to trip for a reverse element directional toward the Transmission system.~~

Since Elements that connect the GSU transformer(s) to the Transmission system that are used exclusively to export energy directly from a BES generating unit or generating plant are applicable to the standard, the loadability for relays applied on these Elements as shown in the shaded area of Figure 2 (i.e., CB102, CB103, CB104, and CB105) must be considered. If relay R2, R3, R4, or R5 is set with an element directional toward the transmission system (e.g., Buses B, C and D) or are non-directional, the relay would be affected by increased generator output in response to system disturbances and must meet the loadability setting criteria described in the standard. If relay R2, R3, R4, or R5 is set with an element directional toward the generator (e.g., Bus A), the relay would not be affected by increased generator output in response to system disturbances; therefore, the entity would not be required to apply the loadability setting criteria described in this standard.

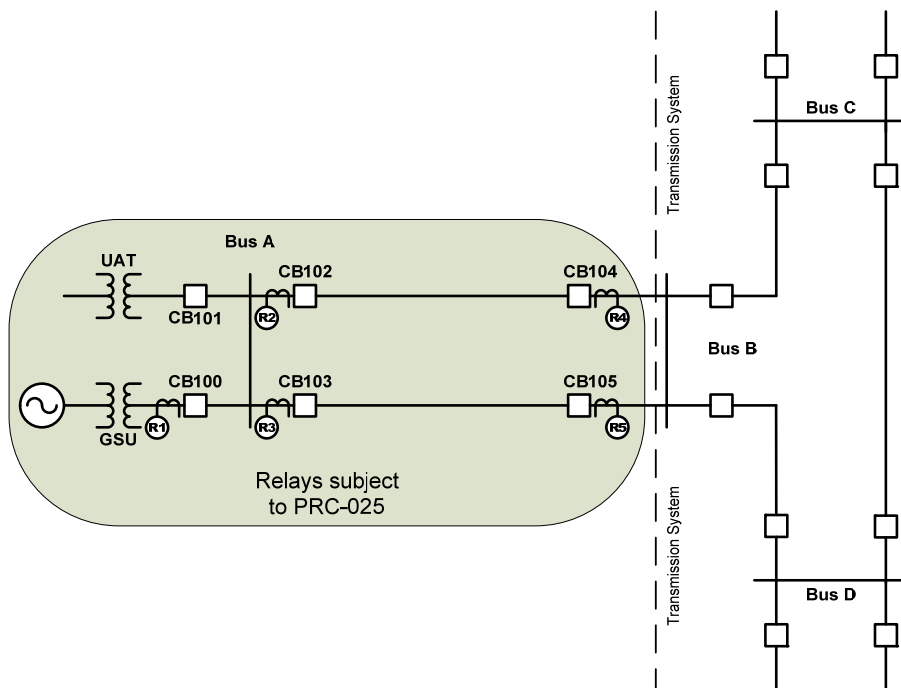

Figure 2: Generation exported through multiple radial lines.

Figure 3

Figure 3 is example a single (or set) of generators exporting power dispersed through multiple lines to the Transmission system through a network. The protective relay R1 on the high-side of the GSU transformer breaker CB100 is generally applied to provide backup protection to the Transmission relaying located at Bus A and in some cases Bus C or Bus D. Under this application, relay R1 would apply the applicable loadability requirement in PRC-025-12 using an appropriate option for the application from Table 1 (e.g., Options 14 through 19) for Elements that connect a GSU transformer to the Transmission system that are used exclusively to export energy directly from a BES generating unit or generating plant.

Since the lines from Bus A to Bus C and from Bus A to Bus D are part of the transmission network, these lines would not be considered as Elements that connect a GSU transformer to the Transmission system that are used exclusively to export energy directly from a BES generating unit or generating plant. Therefore, the applicable responsible entity would be responsible for the load-responsive protective relays R2 and R3 under the PRC-023 standard. The applicable responsible entity’s loadability relays R4 and R5 located on the breakers CB104 and CB105 at Bus C and D are also subject to the requirements of the PRC-023 standard.

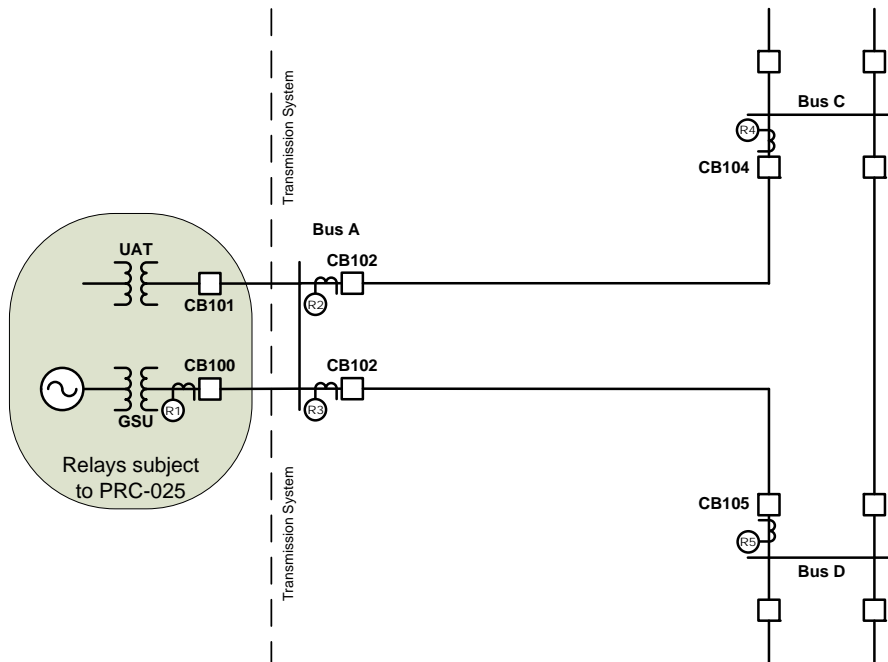

Figure 3: Generation exported through a network.

Elements utilized in the aggregation of dispersed power producing resources (in some cases referred to as a “collector system”) consist of the Elements between individual generating units and the common point of interconnection to the Transmission system.

This standard is also applicable to the UATs that supply station service power to support the on-line operation of generating units or generating plants. These transformers are variably referred to as station power, unit auxiliary transformer(s), or station service transformer(s) used to provide overall auxiliary power to the generator station when the generator is running. Inclusion of these transformers satisfies a directive in FERC Order No. 733, paragraph 104, which directs NERC to include in this standard a loadability requirement for relays used for overload protection of the UAT(s) that supply normal station service for a generating unit. [The NERC System Protection and Control Subcommittee addressed low-side UAT protection in the document called](#)

[Unit Auxiliary Transformer Overcurrent Relay Loadability During a Transmission Depressed Voltage Condition](#),¹⁹ March 2016.

Figure 4
 Elements utilized in the aggregation of dispersed power producing resources (in some cases referred to as a “collector system” or “feeders”) consist of the Elements between individual generating units and the common point of interconnection to the Transmission system.

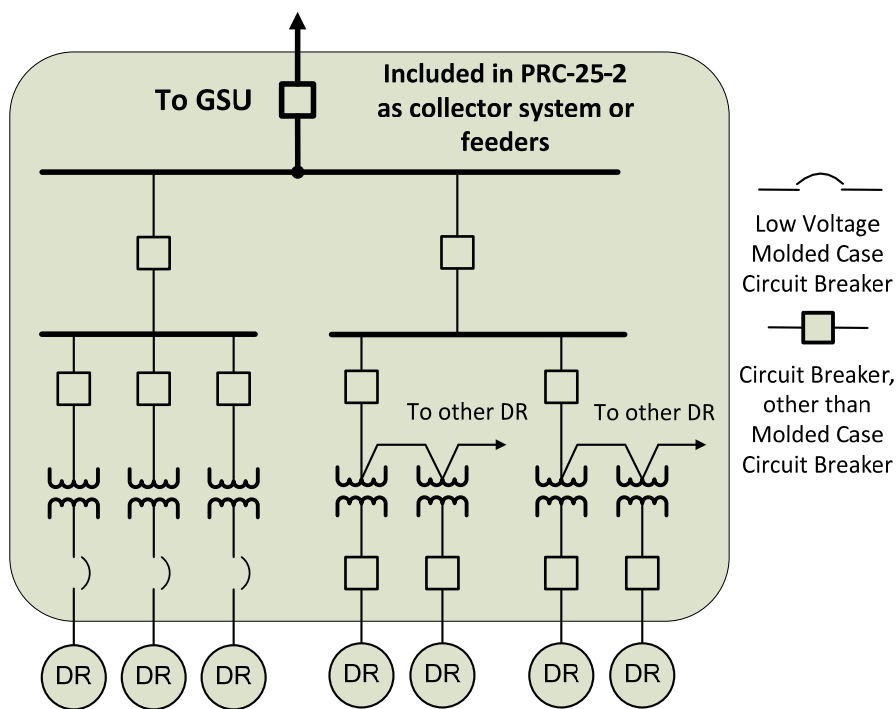

Figure-4: Elements utilized in the aggregation of dispersed power producing resources (DR)

¹⁹ http://www.nerc.com/comm/PC/System%20Protection%20and%20Control%20Subcommittee%20SPCS%2020/NERC%20-%20SPCS%20UAT%20-%20FEB_2016_final.pdf.

Synchronous Generator Performance

When a synchronous generator experiences a depressed voltage, the generator will respond by increasing its Reactive Power output to support the generator terminal voltage. This operating condition, known as “field-forcing,” results in the Reactive Power output exceeding the steady-state capability of the generator and may result in operation of generation system load-responsive protective relays if they are not set to consider this operating condition. The ability of the generating unit to withstand the increased Reactive Power output during field-forcing is limited by the field winding thermal withstand capability. The excitation limiter will respond to begin reducing the level of field-forcing in as little as one second, but may take much longer, depending on the level of field-forcing given the characteristics and application of the excitation system. Since this time may be longer than the time-delay of the generator load-responsive protective relay, it is important to evaluate the loadability to prevent its operation for this condition.

The generator bus voltage during field-forcing will be higher than the high-side voltage due to the voltage drop across the GSU transformer. When the relay voltage is supplied from the generator bus, it is necessary to assess loadability using the generator bus voltage. The criteria established within Table 1 are based on 0.85 per unit of ~~Transmission system~~the line nominal voltage. This voltage was widely observed during the events of August 14, 2003, and was determined during the analysis of the events to represent a condition from which the System may have recovered, had ~~not~~ other undesired behavior not occurred.

The dynamic load levels specified in Table 1 under column “~~Pickup~~–Setting Criteria” are representative of the maximum expected apparent power during field-forcing with the Transmission system voltage at 0.85 per unit, for example, at the high-side of the GSU transformer. These values are based on records from the events leading to the August 14, 2003 blackout, other subsequent System events, and simulations of generating unit responses to similar conditions. Based on these observations, the specified criteria represent conservative but achievable levels of Reactive Power output of the generator with a 0.85 per unit high-side voltage at the point of interconnection.

The dynamic load levels were validated by simulating the response of synchronous generating units to depressed Transmission system voltages for 67 different generating units. The generating units selected for the simulations represented a broad range of generating unit and excitation system characteristics as well as a range of Transmission system interconnection characteristics. The simulations confirmed, for units operating at or near the maximum Real Power output, that it is possible to achieve a Reactive Power output of 1.5 times the rated Real Power output when the Transmission system voltage is depressed to 0.85 per unit. While the simulations demonstrated that all generating units may not be capable of this level of Reactive Power output, the simulations confirmed that approximately 20 percent of the units modeled in the simulations could achieve these levels. On the basis of these levels, Table 1, Options 1a (i.e., 0.95 per unit) and 1b (i.e., 0.85 per unit), for example, are based on relatively simple, but conservative calculations of the high-side nominal voltage. In recognition that not all units are capable of achieving this level of output Option 1c (i.e., simulation) was developed to allow the Generator

Owner, Transmission Owner, or Distribution Provider to simulate the output of a generating unit when the simple calculation is not adequate to achieve the desired protective relay setting.

Dispersed Generation

This standard is applicable to dispersed generation such as wind farms and solar arrays. The intent of this standard is to ensure the aggregate facility as defined above will remain on-line during a system disturbance; therefore, all output load-responsive protective ~~elements~~relays associated with the facility are included in PRC-025.

Dispersed power producing resources with aggregate capacity greater than 75 MVA (gross aggregate nameplate rating) utilizing a system designed primarily for aggregating capacity, connected at a common point at a voltage of 100 kV or above are included in PRC-025-~~4~~2. Load-responsive protective relays that are applied on Elements that connect these individual generating units through the point of interconnection with the Transmission system are within the scope of PRC-025-~~4~~2. For example, feeder overcurrent relays and feeder step-up transformer overcurrent relays (see Figure 56) are included because these relays are challenged by generator loadability.

In the case of solar arrays where there are multiple voltages utilized in converting the solar panel DC output to a 60Hz AC waveform, the “terminal” is defined at the 60Hz AC output of the inverter-solar panel combination.

Asynchronous Generator Performance

Asynchronous generators ~~however, do not have excitation systems and~~ will not respond to a disturbance with the same magnitude of apparent power that a synchronous generator will respond. Asynchronous generators, though, will support the system during a disturbance. Inverter-based generators will provide Real Power and Reactive Power (depending on the installed capability and regional grid code requirements) and may even provide a faster Reactive Power response than a synchronous generator. The magnitude of this response may slightly exceed the steady-state capability of the inverter but only for a short duration before ~~a crowbar function~~limiter functions will activate. Although induction generators will not inherently supply Reactive Power, induction generator installations may include static and/or dynamic reactive devices, depending on regional grid code requirements. These devices also may provide Real Power during a voltage disturbance. Thus, tripping asynchronous generators may exacerbate a disturbance.

Inverters, including wind turbines (i.e., Types 3 and 4) and photovoltaic solar, are commonly available with 0.90 power factor capability. This calculates to an apparent power magnitude of 1.11 per unit of rated MW.

Similarly, induction generator installations, including Type 1 and Type 2 wind turbines, often include static and/or dynamic reactive devices to meet grid code requirements and may have apparent power output similar to inverter-based installations; therefore, it is appropriate to use

the criteria established in the Table 1 (i.e., Options 4, 5, 6, 10, 11, 12, 17, 18, and 19) for asynchronous generator installations.

Synchronous Generator Simulation Criteria

The Generator Owner, Transmission Owner, or Distribution Provider who elects a simulation option to determine the synchronous generator performance on which to base relay settings may simulate the response of a generator by lowering the Transmission system voltage ~~at the remote end of the line or at~~ the high-side of the GSU transformer ~~(as prescribed by the Table 1 criteria)~~. This can be simulated by means such as modeling the connection of a shunt reactor ~~at the Transmission system to lower~~ remote end of the line or at the GSU transformer high-side ~~to lower the~~ voltage to 0.85 per unit prior to field-forcing. The resulting step change in voltage is similar to the sudden voltage depression observed in parts of the Transmission system on August 14, 2003. The initial condition for the simulation should represent the generator at 100 percent of the maximum gross Real Power capability in MW as reported to the Transmission Planner. The simulation is used to determine the Reactive Power and voltage ~~to be used at the relay location~~ to calculate relay pickup setting limits. The Reactive Power value obtained by simulation is the highest simulated level of Reactive Power achieved during field-forcing. The voltage value obtained by simulation is the simulated voltage coincident with the highest Reactive Power achieved during field-forcing. These values of Reactive Power and voltage correspond to the minimum apparent impedance and maximum current observed during field-forcing.

Phase Distance Relay – Directional Toward Transmission System (e.g., 21)

Generator phase distance relays that are directional toward the Transmission system, whether applied for the purpose of primary or backup GSU transformer protection, external system backup protection, or both, were noted during analysis of the August 14, 2003 disturbance event to have unnecessarily or prematurely tripped a number of generating units or generating plants, ~~contributing~~ which contributed to the scope of that disturbance. Specifically, eight generators are known to have been tripped by this protection function. These options establish criteria for phase distance relays that are directional toward the Transmission system to help assure that generators, to the degree possible, will provide System support during disturbances in an effort to minimize the scope of those disturbances.

The phase distance relay that is directional toward the Transmission system measures impedance derived from the quotient of generator terminal voltage divided by generator stator current.

Section 4.6.1.1 of IEEE C37.102-2006, “Guide for AC Generator Protection,” describes the purpose of this protection as follows (emphasis added):

*“The distance relay applied for this function is intended to isolate the generator from the power system for a fault **that is not cleared by the transmission line breakers**. In some cases this relay is set with a very long reach. A condition that causes the generator voltage regulator to boost generator excitation for a sustained period may result in the system apparent impedance, as monitored*

at the generator terminals, to fall within the operating characteristics of the distance relay. Generally, a distance relay setting of 150% to 200% of the generator MVA rating at its rated power factor has been shown to provide good coordination for stable swings, system faults involving in-feed, and **normal loading conditions**. However, this setting may also result in failure of the relay to operate for some line faults where the line relays fail to clear. It is recommended that the setting of these relays be evaluated between the generator protection engineers and the system protection engineers **to optimize coordination while still protecting the turbine generator**. Stability studies may be needed to help determine a set point to optimize protection and coordination. Modern excitation control systems include overexcitation limiting and protection devices to protect the generator field, but the time delay before they reduce excitation is several seconds. In distance relay applications for which the voltage regulator action could cause an incorrect trip, consideration should be given to reducing the reach of the relay and/or coordinating the tripping time delay with the time delays of the protective devices in the voltage regulator. Digital multifunction relays equipped with load encroachment binders [sic] can prevent misoperation for these conditions. **Within its operating zone, the tripping time for this relay must coordinate with the longest time delay for the phase distance relays on the transmission lines connected to the generating substation bus.** With the advent of multifunction generator protection relays, it is becoming more common to use two-phase distance zones. In this case, the second zone would be set as previously described. When two zones are applied for backup protection, the first zone is typically set to see the substation bus (120% of the GSU transformer). This setting should be checked for coordination with the zone-1 element on the shortest line off of the bus. The normal zone-2 time-delay criteria would be used to set the delay for this element. Alternatively, zone-1 can be used to provide high-speed protection for phase faults, in addition to the normal differential protection, in the generator and iso-phase bus with partial coverage of the GSU transformer. For this application, the element would typically be set to 50% of the transformer impedance with little or no intentional time delay. It should be noted that it is possible that this element can operate on an out-of-step power swing condition and provide misleading targeting.”

If a mho phase distance relay that is directional toward the Transmission system cannot be set to maintain reliable fault protection and also meet the criteria in accordance with Table 1, there may be other methods available to do both, such as application of blinders to the existing relays,

implementation of lenticular characteristic relays, application of offset mho relays, or implementation of load encroachment characteristics. Some methods are better suited to improving loadability around a specific operating point, while others improve loadability for a wider area of potential operating points in the R-X plane. The operating point for a stressed System condition can vary due to the pre-event system conditions, severity of the initiating event, and generator characteristics such as Reactive Power capability.

For this reason, it is important to consider the potential implications of revising the shape of the relay characteristic to obtain a longer relay reach, as this practice may result in a relay characteristic that overlaps the capability of the generating unit when operating at a Real Power output level other than 100 percent of the maximum Real Power capability. Overlap of the relay characteristic and generator capability could result in tripping the generating unit for a loading condition within the generating unit capability. The examples in Appendix E of the [Considerations for Power Plant and Transmission System Protection Coordination](#) technical reference document illustrate the potential for, and need to avoid, encroaching on the generating unit capability.

Phase Instantaneous Overcurrent Relay (e.g., 50)

[The 50 element is a non-directional overcurrent element that typically has no intentional time delay. The primary application is for close-in high current faults where high speed operation is required or preferred. The instantaneous overcurrent elements are subject to the same loadability issues as the time overcurrent elements referenced in this standard.](#)

Phase Time Overcurrent Relay (e.g., 51)

See [section 3.9-Chapter 2](#) of the [Considerations for Power Plant and Transmission System Protection Coordination](#) technical reference document for a detailed discussion of this protection function. Note that the [Table 1](#) setting criteria established within the Table 1 options differ from [section 3.9.2](#) of the [Considerations for Power Plant and Transmission System Protection Coordination](#) technical reference document. Rather than establishing a uniform setting threshold of 200 percent of the generator MVA rating at rated power factor for all applications, the Table 1 setting criteria are based on the maximum expected generator Real Power output based on whether the generator [operates as a synchronous or asynchronous unit](#).

Phase Time Overcurrent Relay – Voltage-Restrained (e.g., 51V-R)

Phase time overcurrent voltage-restrained relays (e.g., 51V-R), which change their sensitivity as a function of voltage, whether applied for the purpose of primary or backup GSU transformer protection, for external system phase backup protection, or both, were noted, during analysis of the August 14, 2003 disturbance event to have unnecessarily or prematurely tripped a number of generating units or generating plants, contributing to the scope of that disturbance. Specifically, 20 generators are known to have been tripped by voltage-restrained and voltage-controlled protection functions together. These protective functions are variably referred to by IEEE function numbers 51V, 51R, 51VR, 51V/R, 51V-R, or other terms. See [section 3.10-Chapter 2](#) of the [Considerations for Power Plant and Transmission System Protection Coordination](#) technical reference document for a detailed discussion of this protection function.

Phase Time Overcurrent Relay – Voltage Controlled (e.g., 51V-C)

Phase time overcurrent voltage-controlled relays (e.g., 51V-C), enabled as a function of voltage, are variably referred to by IEEE function numbers 51V, 51C, 51VC, 51V/C, 51V-C, or other terms. See [section 3.10](#) [Chapter 2](#) of the [Considerations for](#) Power Plant and Transmission System Protection Coordination technical reference document for a detailed discussion of this protection function.

Phase Directional ~~Time~~ Overcurrent Relay – Directional Toward Transmission System (e.g., 67)

See [section 3.9](#) [Chapter 2](#) of the [Considerations for](#) Power Plant and Transmission System Protection Coordination technical reference document for a detailed discussion of the phase time overcurrent protection function. The basis for setting directional and non-directional ~~time~~ overcurrent relays is similar. Note that the [Table 1](#) ~~setting~~ [setting](#) criteria established within the Table 1 options differ from [section 3.9.2](#) of the [Considerations for](#) Power Plant and Transmission System Protection Coordination technical reference document. Rather than establishing a uniform setting threshold of 200 percent of the generator MVA rating at rated power factor for all applications, the Table 1 setting criteria are based on the maximum expected generator Real Power output based on whether the generator ~~operates~~ [is a](#) synchronous or asynchronous [unit](#).

Table 1, Options

Introduction

The margins in the Table 1 options are based on guidance found in the [Considerations for Power Plant and Transmission System Protection Coordination](#) technical reference document. The generator bus voltage during field-forcing will be higher than the high-side voltage due to the voltage drop across the GSU transformer. When the relay voltage is supplied from the generator bus, it is necessary to assess loadability using the generator bus voltage.

Relay Connections

Figures 45 and 56 below illustrate the connections for each of the Table 1 options provided in PRC-025-2, Attachment 1: Relay Settings, Table 1: Relay Loadability Evaluation Criteria.

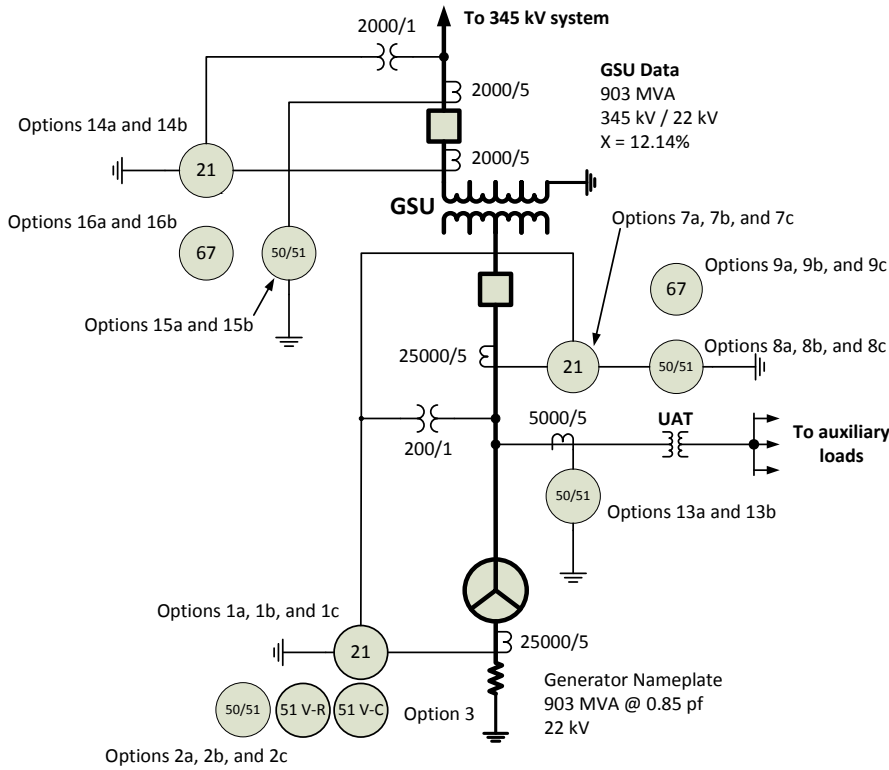

Figure 4-5: Relay Connection for corresponding synchronous options-

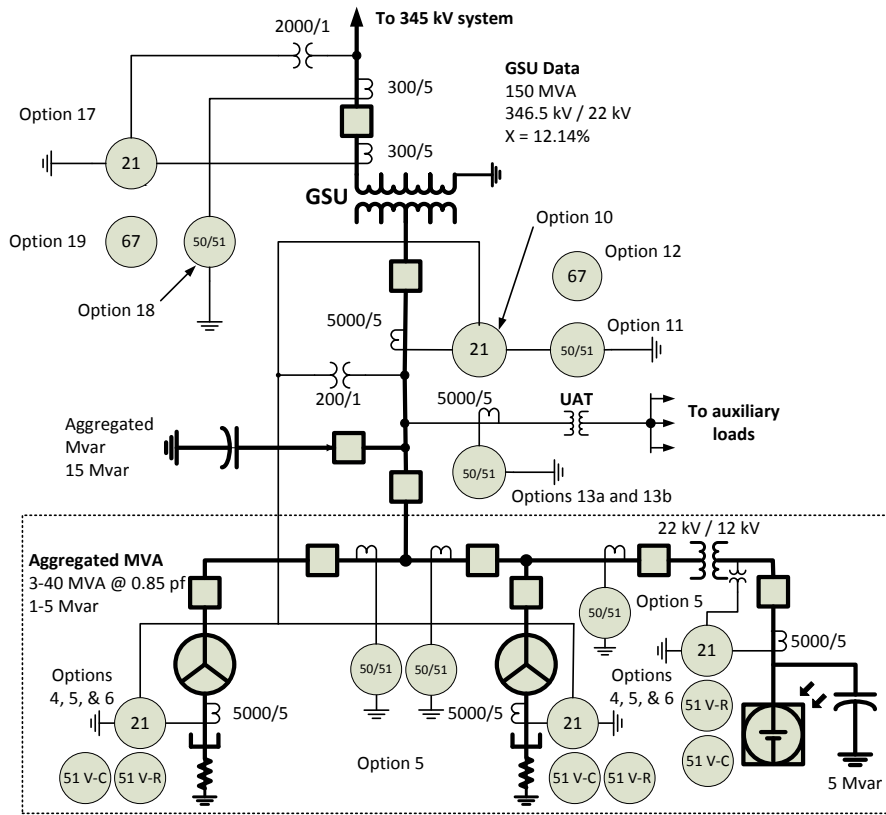

Figure 5-6: Relay Connection for corresponding asynchronous options including inverter-based installations-

Synchronous Generators Phase Distance Relay – Directional Toward Transmission System (e.g., 21) (Options 1a, 1b, and 1c)

Table 1, Options 1a, 1b, and 1c, are provided for assessing loadability for synchronous generators applying phase distance relays that are directional toward the Transmission system. These margins are based on guidance found in [section 3.1-Chapter 2](#) of the [Considerations for Power Plant and Transmission System Protection Coordination](#) technical reference document.

Option 1a calculates a generator bus voltage corresponding to 0.95 per unit nominal voltage on the high-side terminals of the GSU transformer. The generator bus voltage is calculated by multiplying at the 0.95 per unit nominal voltage, at the high-side terminals of the GSU transformer times, by the GSU transformer turns ratio (excluding the impedance). This is the simplest

calculation ~~that approximates~~ is a straightforward way to approximate the stressed system conditions.

Option 1b calculates the generator bus voltage corresponding to 0.85 per unit nominal voltage on the high-side terminals of the GSU transformer. The voltage drop across the GSU transformer is calculated based on a 0.85 per unit nominal voltage at the high-side terminals of the GSU transformer ~~and accounts for~~ as well as the turns ratio and impedance. The actual generator bus voltage may be higher depending on the GSU transformer impedance and the actual Reactive Power achieved. This calculation is a more ~~involved, more in-depth and~~ precise method for setting of the impedance element than Option 1a.

Option 1c simulates the generator bus voltage coincident with the highest Reactive Power output achieved during field-forcing. This output is in response to a 0.85 per unit nominal voltage on the high-side terminals of the GSU transformer prior to field-forcing. Using simulation is a more involved, more precise setting of the impedance element overall.

For Options 1a and 1b, the impedance element ~~is~~ shall be set less than the calculated impedance derived from ~~115 percent~~ 115 percent of both: the Real Power output of 100 percent of the maximum gross MW capability reported to the Transmission Planner, and the Reactive Power output that equates to 150 percent of the MW value, derived from the generator nameplate MVA rating at rated power factor.

For Option 1c, the impedance element ~~is~~ shall be set less than the calculated impedance derived from 115 percent of both: the Real Power output of 100 percent of the maximum gross MW capability reported to the Transmission Planner, and the Reactive Power output that equates to 100 percent of the maximum gross Mvar output during field-forcing as determined by simulation.

Synchronous Generators Phase ~~Time~~ Overcurrent Relay – (e.g., 50, 51, or 51V-R – Voltage-Restrained ~~(51V-R)~~) (Options 2a, 2b, and 2c)

Table 1, Options 2a, 2b, and 2c, are provided for assessing loadability for synchronous generators applying phase ~~time~~ overcurrent relays ~~which change their sensitivity as a function of~~ (e.g., 50, 51, or 51V-R – voltage (“voltage-restricted”)). These margins are based on guidance found in ~~section 3.10~~ Chapter 2 of the Considerations for Power Plant and Transmission System Protection Coordination technical reference document.

Option 2a calculates a generator bus voltage corresponding to 0.95 per unit nominal voltage on the high-side terminals of the GSU transformer. The generator bus voltage is calculated by multiplying ~~at~~ the 0.95 per unit nominal voltage, at the high-side terminals of the GSU transformer ~~times, by~~ the GSU transformer turns ratio (excluding the impedance). This ~~is the simplest~~ calculation ~~that approximates~~ is a straightforward way to approximate the stressed system conditions.

Option 2b calculates the generator bus voltage corresponding to 0.85 per unit nominal voltage on the high-side terminals of the GSU transformer. The voltage drop across the GSU transformer

is calculated based on a 0.85 per unit nominal voltage at the high-side terminals of the GSU transformer ~~and accounts as well as~~ for the turns ratio and impedance. The actual generator bus voltage may be higher depending on the GSU transformer impedance and the actual Reactive Power achieved. This calculation is a more ~~involved, more in-depth and~~ precise ~~method for~~ setting of the overcurrent element than Option 2a.

Option 2c simulates the generator bus voltage coincident with the highest Reactive Power output achieved during field-forcing. ~~This output is~~ in response to a 0.85 per unit nominal voltage on the high-side terminals of the GSU transformer prior to field-forcing. Using simulation is a more involved, more precise setting of the overcurrent element overall.

For Options 2a and 2b, the overcurrent element ~~is shall be~~ set greater than 115 percent of the calculated current derived from ~~both~~: the Real Power output of 100 percent of the maximum gross MW capability reported to the Transmission Planner, and ~~the~~ Reactive Power output that equates to 150 percent of the MW value, derived from the generator nameplate MVA rating at rated power factor.

For Option 2c, the overcurrent element ~~is shall be~~ set greater than the calculated current derived from 115 percent of ~~both~~: the Real Power output of 100 percent of the maximum gross MW capability reported to the Transmission Planner, and ~~the~~ Reactive Power output that equates to 100 percent of the maximum gross Mvar output during field-forcing as determined by simulation.

Synchronous Generators Phase Time Overcurrent Relay – Voltage Controlled (e.g., 51V-C) (Option 3)

Table 1, Option 3, is provided for assessing loadability for synchronous generators applying phase time overcurrent relays which are enabled as a function of voltage (“voltage-controlled”). These margins are based on guidance found in ~~section 3.10~~Chapter 2 of the ~~Considerations for~~ Power Plant and Transmission System Protection Coordination technical reference document.

Option 3 calculates the generator bus voltage corresponding to 1.0 per unit nominal voltage on the high-side terminals of the GSU transformer. The generator bus voltage is calculated by multiplying ~~at the~~ 1.0 per unit nominal voltage, ~~at~~ the high-side terminals of the GSU transformer ~~times, by~~ the GSU transformer turns ratio (excluding the impedance). This is a simple calculation that approximates the stressed system conditions.

For Option 3, the voltage control setting ~~is shall be~~ set less than 75 percent of the calculated generator bus voltage. The voltage setting must be set such that the function (e.g., 51V-C) will not trip under extreme emergency conditions as the time overcurrent function will be set less than generator full load current. Relays enabled as a function of voltage are indifferent as to the current setting, and this option simply requires that the relays not respond for the depressed voltage.

Asynchronous Generators Phase Distance Relay – Directional Toward Transmission System (e.g., 21) (Option 4)

Table 1, Option 4 is provided for assessing loadability for asynchronous generators applying phase distance relays that are directional toward the Transmission system. These margins are based on guidance found in ~~section 3-1~~Chapter 2 of the Considerations for Power Plant and Transmission System Protection Coordination technical reference document.

Option 4 calculates the generator bus voltage corresponding to 1.0 per unit nominal voltage on the high-side terminals of the GSU transformer. The generator bus voltage is calculated by multiplying ~~at the~~ 1.0 per unit nominal voltage₂ at the high-side terminals of the GSU transformer ~~times, by~~ the GSU transformer turns ratio (excluding the impedance). This is a simple calculation that approximates the stressed system conditions.

Since the relay voltage is supplied from the generator bus, it is necessary to assess loadability using the generator-side voltage. Asynchronous generators do not produce as much Reactive Power as synchronous generators; the voltage drop due to Reactive Power flow through the GSU transformer is not as significant. Therefore, the generator bus voltage can be conservatively estimated by reflecting the high-side nominal voltage to the generator-side based on the GSU transformer's turns ratio.

For Option 4, the impedance element ~~is~~shall be set less than the calculated impedance derived from 130 percent of the maximum aggregate nameplate MVA output at rated power factor including the Mvar output of any static or dynamic Reactive Power devices. This is determined by summing the total MW and Mvar capability of the generation equipment behind the relay and any static or dynamic Reactive Power devices that contribute to the power flow through the relay.

Asynchronous Generators Phase ~~Time~~ Overcurrent Relay – (e.g., 50, 51, or 51V-R – Voltage -Restrained) ~~(51V-R) (Option 5) (Options 5a and 5b)~~

Table 1, Option ~~55a~~ is provided for assessing loadability for asynchronous generators applying phase ~~time~~ overcurrent relays ~~which change their sensitivity as a function of~~(e.g., 50, 51, or 51V-R – voltage –(“voltage-restrained”)). These margins are based on guidance found in ~~section 3-10~~Chapter 2 of the Considerations for Power Plant and Transmission System Protection Coordination technical reference document.

Option ~~55a~~ calculates the generator bus voltage corresponding to 1.0 per unit nominal voltage on the high-side terminals of the GSU transformer. The generator bus voltage is calculated by multiplying ~~at the~~ 1.0 per unit nominal voltage₂ at the high-side terminals of the GSU transformer ~~times, by~~ the GSU transformer turns ratio (excluding the impedance). This is a simple calculation that approximates the stressed system conditions.

Since the relay voltage is supplied from the generator bus, it is necessary to assess loadability using the generator-side voltage. Asynchronous generators do not produce as much Reactive Power as synchronous generators; the voltage drop due to Reactive Power flow through the GSU

transformer is not as significant. Therefore, the generator bus voltage can be conservatively estimated by reflecting the high-side nominal voltage to the generator-side based on the GSU transformer's turns ratio.

For Option [55a](#), the overcurrent element ~~is~~ shall be set greater than 130 percent of the calculated current derived from the maximum aggregate nameplate MVA output at rated power factor including the Mvar output of any static or dynamic Reactive Power devices. This is determined by summing the total MW and Mvar capability of the generation equipment behind the relay and any static or dynamic Reactive Power devices that contribute to the power flow through the relay.

For Option 5b, the overcurrent element shall be set to exceed the maximum capability of the asynchronous resource and applicable equipment (e.g., windings, power electronics, cables, or bus). This is determined by summing the total current capability of the generation equipment behind the overcurrent element and any static or dynamic Reactive Power devices that contribute to the power flow through the overcurrent element. The lower tolerance of the overcurrent element tripping characteristic shall be set to not infringe upon the resource capability (including the Mvar output of the resource and any static or dynamic reactive power devices). Figure A of PRC-025-2 illustrates that the overcurrent element does not infringe upon the asynchronous resource capability. The upper hashed area of Figure A represents Exclusion 7.

Asynchronous Generator Phase Time Overcurrent Relays – Voltage Controlled (e.g., 51V-C) (Option 6)

Table 1, Option 6, is provided for assessing loadability for asynchronous generators applying phase time overcurrent relays which are enabled as a function of voltage (“voltage-controlled”). These margins are based on guidance found in [section 3.10Chapter 2](#) of the [Considerations for Power Plant and Transmission System Protection Coordination](#) technical reference document.

Option 6 calculates the generator bus voltage corresponding to 1.0 per unit nominal voltage on the high-side terminals of the GSU transformer. The generator bus voltage is calculated by multiplying ~~at~~ the 1.0 per unit nominal voltage ~~at~~ the high-side terminals of the GSU transformer ~~times, by~~ the GSU transformer turns ratio (excluding the impedance). This is a simple calculation that approximates the stressed system conditions.

For Option 6, the voltage control setting ~~is~~ shall be set less than 75 percent of the calculated generator bus voltage. The voltage setting must be set such that the function (e.g., 51V-C) will not trip under extreme emergency conditions as the time overcurrent function will be set less than generator full load current. Relays enabled as a function of voltage are indifferent as to the current setting, and this option simply requires that the relays not respond for the depressed voltage.

Generator Step-up Transformer (Synchronous Generators) Phase Distance Relays – Directional Toward Transmission System (e.g., 21) (Options 7a, 7b, and 7c)

The Federal Energy Regulatory Commission, in FERC Order No. 733, paragraph 104, directs that NERC address relay loadability for protective relays applied on GSU transformers. These margins are based on guidance found in ~~section 3.1~~ Chapter 2 of the Considerations for Power Plant and Transmission System Protection Coordination technical reference document.

Table 1, Options 7a, 7b, and 7c, are provided for assessing loadability ~~for GSU transformers applying of~~ phase distance relays that are directional toward the Transmission system ~~on synchronous generators that are~~ and connected to the generator-side of the GSU transformer of a synchronous generator. ~~Where~~ For applications where the relay is connected on the high-side of the GSU transformer, use Option 14.

Option 7a calculates a generator bus voltage corresponding to 0.95 per unit nominal voltage on the high-side terminals of the GSU transformer. The generator bus voltage is calculated by multiplying at the 0.95 per unit nominal voltage, at the high-side terminals of the GSU transformer ~~times, by~~ the GSU transformer turns ratio (excluding the impedance). This ~~is the simplest~~ calculation ~~that approximates~~ is a straightforward way to approximate the stressed system conditions.

Option 7b calculates the generator bus voltage corresponding to 0.85 per unit nominal voltage on the high-side terminals of the GSU transformer. The voltage drop across the GSU transformer is calculated based on at the 0.85 per unit nominal voltage, at the high-side terminals of the GSU transformer ~~and accounts for, as well as~~ the turns ratio and impedance. The actual generator bus voltage may be higher depending on the GSU transformer impedance and the actual Reactive Power achieved. This calculation is a more ~~involved, more in-depth and~~ precise method for setting ~~of~~ the impedance element than Option 7a.

Option 7c simulates the generator bus voltage coincident with the highest Reactive Power output achieved during field-forcing. This output is in response to a 0.85 per unit nominal voltage on the high-side terminals of the GSU transformer prior to field-forcing. Using simulation is a more ~~involved, more in-depth and~~ precise method for setting ~~of the overcurrent impedance~~ element ~~overall than~~ Options 7a or 7b.

For Options 7a and 7b, the impedance element ~~is~~ shall be set less than the calculated impedance derived from 115 percent of both: the Real Power output of 100 percent of the aggregate generation MW capability reported to the Transmission Planner, and the Reactive Power output that equates to 150 percent of the aggregate generation MW value, ~~(derived from the generator nameplate MVA rating at rated power factor-).~~

For Option 7c, the impedance element ~~is~~ shall be set less than the calculated impedance derived from 115 percent of both: the Real Power output of 100 percent of the aggregate generation MW capability reported to the Transmission Planner, and the Reactive Power output that

equates to 100 percent of the maximum gross Mvar output during field-forcing as determined by simulation.

Generator Step-up Transformer (Synchronous Generators) Phase ~~Time~~ Overcurrent Relay (e.g., 50 or 51) (Options 8a, 8b and 8c)

The Federal Energy Regulatory Commission, in FERC Order No. 733, paragraph 104, directs that NERC address relay loadability for protective relays applied on GSU transformers. Note that the setting criteria established within ~~these~~the Table 1 options differ from ~~section 3.9-Chapter 2~~ of the Considerations for Power Plant and Transmission System Protection Coordination technical reference document. Rather than establishing a uniform ~~setting/loadability~~ threshold of 200 percent of the generator nameplate MVA rating at rated power factor for all applications, the setting criteria are based on the maximum expected generator output.

Table 1, Options 8a, 8b, and 8c, are provided for assessing loadability ~~for GSU transformers applying of~~ phase ~~time~~-overcurrent relays ~~on synchronous generators~~ that are connected to the generator-side of the GSU transformer of a synchronous generator. ~~Where~~For applications where the relay is connected on the high-side of the GSU transformer, use Option 15.

Option 8a calculates a generator bus voltage corresponding to 0.95 per unit nominal voltage on the high-side terminals of the GSU transformer. The generator bus voltage is calculated by multiplying ~~at~~the 0.95 per unit nominal voltage, ~~at~~ the high-side terminals of the GSU transformer ~~times, by~~ the GSU transformer turns ratio (excluding the impedance). This ~~is the simplest~~ calculation ~~that approximates~~is a straightforward way to approximate the stressed system conditions.

Option 8b calculates the generator bus voltage corresponding to 0.85 per unit nominal voltage on the high-side terminals of the GSU transformer. The voltage drop across the GSU transformer is calculated based on ~~a~~the 0.85 per unit nominal voltage, ~~at~~ the high-side terminals of the GSU transformer ~~and accounts for, as well as~~ the turns ratio and impedance. The actual generator bus voltage may be higher depending on the GSU transformer impedance and the actual Reactive Power achieved. This calculation is a more ~~involved, more in-depth and~~ precise method for setting ~~of the impedance overcurrent~~ element than Option 8a.

Option 8c simulates the generator bus voltage coincident with the highest Reactive Power output achieved during field-forcing. ~~This output is~~ in response to a 0.85 per unit nominal voltage on the high-side terminals of the GSU transformer prior to field-forcing. Using simulation is a more ~~involved, more in-depth and~~ precise method for setting ~~of the overcurrent element overall than~~ Options 8a or 8b.

For Options 8a and 8b, the overcurrent element ~~is~~shall be set greater than 115 percent of the calculated current derived from ~~both~~: the Real Power output of 100 percent of the aggregate generation MW capability reported to the Transmission Planner, and ~~the~~ Reactive Power output that equates to 150 percent of the aggregate generation MW value, ~~(derived from the generator nameplate MVA rating at rated power factor).~~

For Option 8c, the overcurrent element ~~is shall be~~ set greater than 115 percent of the calculated current derived from ~~both~~: the Real Power output of 100 percent of the aggregate generation MW capability reported to the Transmission Planner, and ~~the~~ Reactive Power output that equates to 100 percent of the maximum gross Mvar output during field-forcing as determined by simulation.

Generator Step-up Transformer (Synchronous Generators) Phase Directional ~~Time~~ Overcurrent Relay – Directional Toward Transmission System (e.g., 67) (Options 9a, 9b and 9c)

The Federal Energy Regulatory Commission, in FERC Order No. 733, paragraph 104, directs that NERC address relay loadability for protective relays applied on GSU transformers. Note that the setting criteria established within ~~these~~ Table 1 options differ from ~~section 3.9-Chapter 2~~ of the Considerations for Power Plant and Transmission System Protection Coordination technical reference document. Rather than establishing a uniform ~~setting~~ loadability threshold of 200 percent of the generator nameplate MVA rating at rated power factor for all applications, the setting criteria are based on the maximum expected generator output.

Table 1, Options 9a, 9b, and 9c, are provided for assessing loadability ~~for GSU transformers applying of~~ phase directional ~~time~~ overcurrent relays directional toward the Transmission System that are connected to the generator-side of the GSU transformer of a synchronous generator. ~~Where~~ For applications where the relay is connected on the high-side of the GSU transformer, use Option 16.

Option 9a calculates a generator bus voltage corresponding to 0.95 per unit nominal voltage on the high-side terminals of the GSU transformer. The generator bus voltage is calculated by multiplying ~~at the~~ 0.95 per unit nominal voltage, at the high-side terminals of the GSU transformer ~~times, by~~ the GSU transformer turns ratio (excluding the impedance). This ~~is the simplest~~ calculation ~~that approximates~~ a straightforward way to approximate the stressed system conditions.

Option 9b calculates the generator bus voltage corresponding to 0.85 per unit nominal voltage on the high-side terminals of the GSU transformer. The voltage drop across the GSU transformer is calculated based on ~~at the~~ 0.85 per unit nominal voltage, at the high-side terminals of the GSU transformer ~~and accounts for, as well as~~ the turns ratio and impedance. The actual generator bus voltage may be higher depending on the GSU transformer impedance and the actual Reactive Power achieved. This calculation is a more ~~involved, more in-depth and~~ precise method for setting ~~of the impedance overcurrent~~ element than Option 9a.

Option 9c simulates the generator bus voltage coincident with the highest Reactive Power output achieved during field-forcing. This output is in response to a 0.85 per unit nominal voltage on the high-side terminals of the GSU transformer prior to field-forcing. Using simulation is a more ~~involved, more in-depth and~~ precise method for setting ~~of the overcurrent element overall than~~ Options 9a or 9b.

For Options 9a and 9b, the overcurrent element ~~is~~shall be set greater than 115 percent of the calculated current derived from both: the Real Power output of 100 percent of the aggregate generation MW capability reported to the Transmission Planner, and the Reactive Power output that equates to 150 percent of the aggregate generation MW value, ~~(derived from the generator nameplate MVA rating at rated power factor).~~

For Option 9c, the overcurrent element ~~is~~shall be set greater than 115 percent of the calculated current derived from both: the Real Power output of 100 percent of the aggregate generation MW capability reported to the Transmission Planner, and the Reactive Power output that equates to 100 percent of the maximum gross Mvar output during field-forcing as determined by simulation.

Generator Step-up Transformer (Asynchronous Generators) Phase Distance Relay – Directional Toward Transmission System (e.g., 21) (Option 10)

The Federal Energy Regulatory Commission, in FERC Order No. 733, paragraph 104, directs that NERC address relay loadability for protective relays applied on GSU transformers. Table 1, Option 10 is provided for assessing loadability for GSU transformers applying phase distance relays that are directional toward the Transmission System that are connected to the generator-side of the GSU transformer of an asynchronous generator. These margins are based on guidance found in ~~section 3.1~~Chapter 2 of the Considerations for Power Plant and Transmission System Protection Coordination technical reference document. ~~Where~~For applications where the relay is connected on the high-side of the GSU transformer, use Option 17.

Option 10 calculates the generator bus voltage corresponding to 1.0 per unit nominal voltage on the high-side terminals of the GSU transformer. The generator bus voltage is calculated by multiplying atthe 1.0 per unit nominal voltage, at the high-side terminals of the GSU transformer ~~times, by~~ the GSU transformer turns ratio (excluding the impedance). This ~~is a simple~~ calculation ~~that approximates~~ is a straightforward way to approximate the stressed system conditions.

Since the relay voltage is supplied from the generator bus, it is necessary to assess loadability using the generator-side voltage. Asynchronous generators do not produce as much Reactive Power as synchronous generators; hence the voltage drop due to Reactive Power flow through the GSU transformer is not as significant. Therefore, the generator bus voltage can be conservatively estimated by reflecting the high-side nominal voltage to the generator-side based on the GSU transformer's turns ratio.

For Option 10, the impedance element ~~is~~shall be set less than the calculated impedance, derived from 130 percent of the maximum aggregate nameplate MVA output at rated power factor, including the Mvar output of any static or dynamic Reactive Power devices. This is determined by summing the total MW and Mvar capability of the generation equipment behind the relay and any static or dynamic Reactive Power devices that contribute to the power flow through the relay.

Generator Step-up Transformer (Asynchronous Generators) Phase ~~Time~~ Overcurrent Relay (e.g., 50 or 51) (Option 11)

The Federal Energy Regulatory Commission, in FERC Order No. 733, paragraph 104, directs that NERC address relay loadability for protective relays applied on GSU transformers. Note that the setting criteria established within ~~these~~ [Table 1](#) options differ from ~~section 3.9-Chapter 2~~ of the [Considerations for](#) Power Plant and Transmission System Protection Coordination technical reference document. Rather than establishing a uniform ~~setting/loadability~~ threshold of 200 percent of the generator nameplate MVA rating at rated power factor for all applications, the setting criteria are based on the maximum expected generator output.

Table 1, Option 11 is provided for assessing loadability ~~for GSU transformers applying of~~ phase ~~time~~ overcurrent relays ~~on asynchronous generators~~ that are connected to the generator-side of the GSU transformer. ~~Where of an asynchronous generator. For applications where~~ the relay is connected on the high-side of the GSU transformer, use Option 18.

Option 11 calculates the generator bus voltage corresponding to 1.0 per unit nominal voltage on the high-side terminals of the GSU transformer. The generator bus voltage is calculated by multiplying ~~at~~ the 1.0 per unit nominal voltage, at the high-side terminals of the GSU transformer ~~times, by~~ the GSU transformer turns ratio (excluding the impedance). This ~~is a simple~~ calculation ~~that approximates~~ [is a straightforward way to approximate](#) the stressed system conditions.

Since the relay current is supplied from the generator bus, it is necessary to assess loadability using the generator-side voltage. Asynchronous generators do not produce as much Reactive Power as synchronous generators; ~~hence~~ the voltage drop due to Reactive Power flow through the GSU transformer is not as significant. Therefore, the generator bus voltage can be conservatively estimated by reflecting the high-side nominal voltage to the generator-side based on the GSU transformer's turns ratio.

For Option 11, the overcurrent element ~~is~~ [shall be](#) set greater than 130 percent of the calculated current derived from the maximum aggregate nameplate MVA output at rated power factor, including the Mvar output of any static or dynamic Reactive Power devices. This is determined by summing the total MW and Mvar capability of the generation equipment behind the relay and any static or dynamic Reactive Power devices that contribute to the power flow through the relay.

Generator Step-up Transformer (Asynchronous Generators) Phase Directional ~~Time~~ Overcurrent Relay – Directional Toward Transmission System (e.g., 67) (Option 12)

The Federal Energy Regulatory Commission, in FERC Order No. 733, paragraph 104, directs that NERC address relay loadability for protective relays applied on GSU transformers. Note that the setting criteria established within ~~these~~ [Table 1](#) options differ from ~~section 3.9-Chapter 2~~ of the [Considerations for](#) Power Plant and Transmission System Protection Coordination technical reference document. Rather than establishing a uniform ~~setting/loadability~~ threshold of 200 percent of the generator nameplate MVA rating at rated power factor for all applications, the setting criteria are based on the maximum expected generator output.

Table 1, Option 12 is provided for assessing loadability ~~for GSU transformers applying of~~ phase directional ~~time~~ overcurrent relays directional toward the Transmission System ~~on asynchronous generators~~ that are connected to the generator-side of the GSU transformer of an asynchronous generator. ~~Where~~ For applications where the relay is connected on the high-side of the GSU transformer, use Option 19.

Option 12 calculates the generator bus voltage corresponding to 1.0 per unit nominal voltage on the high-side terminals of the GSU transformer. The generator bus voltage is calculated by multiplying ~~at the~~ 1.0 per unit nominal voltage, at the high-side terminals of the GSU transformer ~~times, by~~ the GSU transformer turns ratio (excluding the impedance). This ~~is a simple calculation that approximates~~ is a straightforward way to approximate the stressed system conditions.

Since the relay current is supplied from the generator bus, it is necessary to assess loadability using the generator-side voltage. Asynchronous generators do not produce as much Reactive Power as synchronous generators; hence the voltage drop due to Reactive Power flow through the GSU transformer is not as significant. Therefore, the generator bus voltage can be conservatively estimated by reflecting the high-side nominal voltage to the generator-side based on the GSU transformer's turns ratio.

For Option 12, the overcurrent element ~~is~~ shall be set greater than 130 percent of the calculated current derived from the maximum aggregate nameplate MVA output at rated power factor, including the Mvar output of any static or dynamic Reactive Power devices. This is determined by summing the total MW and Mvar capability of the generation equipment behind the relay and any static or dynamic Reactive Power devices that contribute to the power flow through the relay.

Unit Auxiliary Transformers Phase ~~Time~~ Overcurrent Relay (e.g., 50 or 51) (Options 13a and 13b)

In FERC Order No. 733, paragraph 104, directs NERC to include in this standard a loadability requirement for relays used for overload protection of the UAT that supply normal station service for a generating unit. For the purposes of this standard, UATs provide the overall station power to support the unit at its maximum gross operation.

Table 1, Options 13a and 13b provide two options for addressing phase ~~time~~ overcurrent relaying applied at the high-side of UATs. The transformer high-side winding may be directly connected to the transmission grid or at the generator isolated phase bus (IPB) or iso-phase bus. Phase ~~time~~ overcurrent relays applied at the high-side of the UAT that remove the transformer from service resulting in an immediate (e.g., via lockout or auxiliary tripping relay operation) or consequential trip of the associated generator are to be compliant with the relay setting criteria in this standard. Due to the complexity of the application of low-side overload relays for single or multi-winding transformers, phase ~~time~~ overcurrent relaying applied ~~at the low-side of~~ the UAT are not addressed in this standard. The NERC System Protection and Control Subcommittee addressed low-side UAT protection in the document called "Unit Auxiliary Transformer Overcurrent Relay

[Loadability During a Transmission Depressed Voltage Condition, March 2016.](#) These relays include, but are not limited to, a relay used for arc flash protection, feeder protection relays, breaker failure, and relays whose operation may result in a generator runback. [Although the UAT is not directly in the output path from the generator to the Transmission system, it is an essential component for operation of the generating unit or plant.](#)

Refer to the Figures [67](#) and [78](#) below for example configurations:

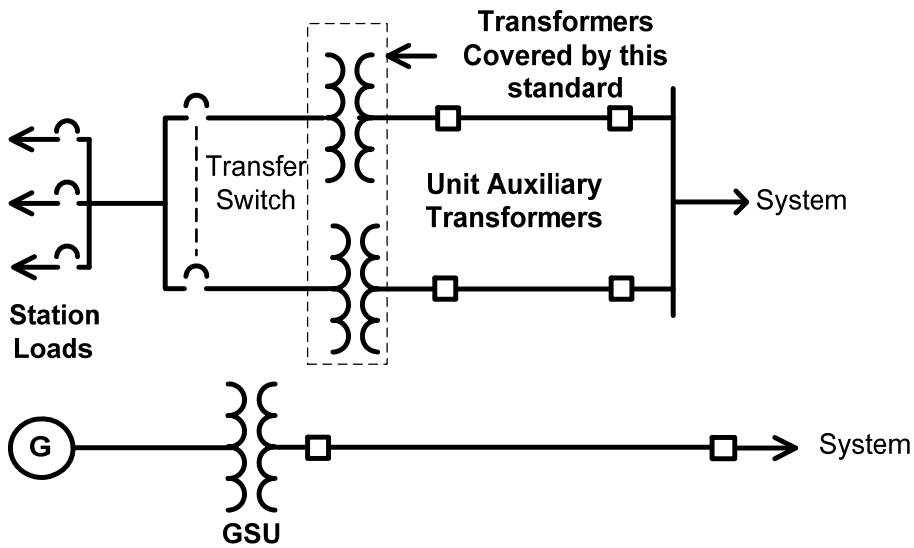

Figure 6-7: Auxiliary Power System (independent from generator)

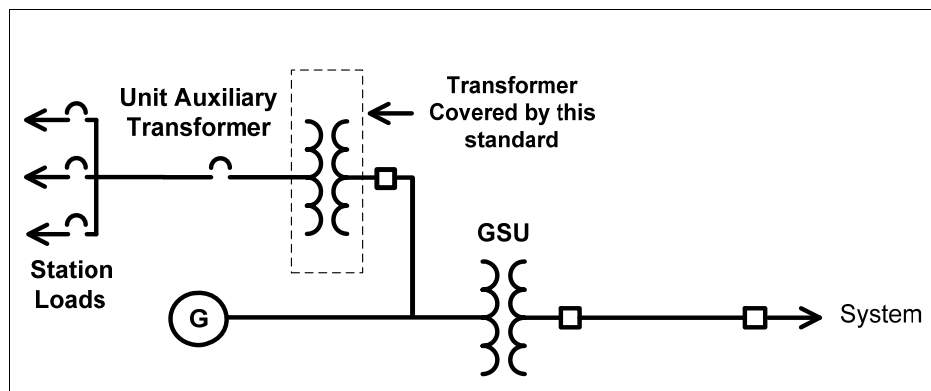

Figure 7-8: Typical auxiliary power system for generation units or plants.

The UATs supplying power to the unit or plant electrical auxiliaries are sized to accommodate the maximum expected overall UAT load demand at the highest generator output. Although the transformer nameplate MVA size normally includes capacity for future loads as well as capacity for starting of large induction motors on the original unit or plant design, the nameplate MVA capacity of the transformer may be near full load.

Because of the various design and loading characteristics of UATs, two options (i.e., 13a and 13b) are provided to accommodate an entity's protection philosophy while preventing the UAT transformer phase ~~time~~ overcurrent relays from operating during the dynamic conditions anticipated by this standard.

Options 13a and 13b are based on the transformer bus voltage corresponding to 1.0 per unit nominal voltage on the high-side winding of the UAT.

For Option 13a, the overcurrent element shall be set greater than 150 percent of the calculated current derived from the UAT maximum nameplate MVA rating. This is a simple calculation that approximates the stressed system conditions.

For Option 13b, the overcurrent element shall be set greater than 150 percent of the UAT measured current at the generator maximum gross MW capability reported to the Transmission Planner. This allows for a reduced setting ~~pickup~~ compared to Option 13a and the ~~entity's~~ relay setting philosophy of the applicable entity. This is a more involved calculation that approximates the stressed system conditions by allowing the entity to consider the actual load placed on the UAT based on the generator's maximum gross MW capability reported to the Transmission Planner.

The performance of the UAT loads during stressed system conditions (i.e., depressed voltages) is very difficult to determine. Rather than requiring responsible entities to determine the response

of UAT loads to depressed voltage, the technical experts writing the standard elected to increase the margin to 150 percent from that used elsewhere in this standard (e.g., 115 percent) and use a generator bus voltage of 1.0 per unit. A minimum pickup setting current based on 150 percent of maximum transformer nameplate MVA rating at 1.0 per unit generator bus voltage will provide adequate transformer protection based on IEEE C37.91 at full load conditions while providing sufficient relay loadability to prevent a trip of the UAT, and subsequent unit trip, due to increased UAT load current during stressed system voltage conditions. Even if the UAT is equipped with an automatic tap changer, the tap changer may not respond quickly enough for the conditions anticipated within this standard, and thus shall not be used to reduce this margin.

Elements that connect a GSU transformer to the Transmission system that are used exclusively to export energy directly from a BES generating unit or generating plant (Synchronous Generators) Phase Distance Relays – Directional Toward Transmission System (e.g., 21) (Options 14a and 14b)

Relays applied on Elements that connect a GSU transformer to the Transmission system that are used exclusively to export energy directly from a BES generating unit or generating plant are challenged by loading conditions similar to relays applied on generators and GSU transformers. These margins are based on guidance found in [section 3.1-Chapter 2](#) of the [Considerations for Power Plant and Transmission System Protection Coordination](#) technical reference document. Relays applied on the high-side of the GSU transformer respond to the same quantities as the relays ~~connected on the~~[applied at the remote end of the line for](#) Elements that connect a GSU transformer to the Transmission system that are used exclusively to export energy directly from a BES generating unit or generating plant, thus Option 14 is used for these relays as well.

Table 1, Options 14a and 14b, establish criteria for phase distance relays directional toward the Transmission system to prevent Elements that connect a GSU transformer to the Transmission system that are used exclusively to export energy directly from a BES generating unit or generating plant from ~~operating tripping~~ during the dynamic conditions anticipated by this standard. The stressed system conditions, anticipated by Option 14a reflects a 0.85 per unit ~~Transmission system of the line nominal~~ voltage; therefore, establishing that the impedance value used for applying the Elements that connect a GSU transformer to the Transmission system that are used exclusively to export energy directly from a BES generating unit or generating plant phase distance relays that are directional toward the Transmission system be calculated from the apparent power addressed within the criteria, with application of a 0.85 per unit ~~Transmission system of the line nominal~~ voltage [at the relay location](#). Consideration of the voltage drop across the GSU transformer is not necessary. Option 14b simulates the line voltage coincident with the highest Reactive Power output achieved during field-forcing in response to a 0.85 per unit ~~nominal voltage on the high side terminals of the GSU transformer prior to field forcing-line nominal voltage at the remote end of the line prior to field-forcing. Using a 0.85 per unit line nominal voltage at the remote end of the line is representative of the lowest voltage expected during a depressed voltage condition on Elements that are used exclusively to export energy directly from a BES generating unit or generating plant to the Transmission system.~~ Using simulation is a more involved, more precise setting of the overcurrent element overall.

For Option 14a, the impedance element ~~is~~shall be set less than the calculated impedance derived from 115 percent of ~~both~~: the Real Power output of 100 percent of the aggregate generation MW capability reported to the Transmission Planner, and ~~the~~ Reactive Power output that equates to 120 percent of the aggregate generation MW value, derived from the generator nameplate MVA rating at rated power factor. This Reactive Power value differs from the 150 percent multiplier used in other ~~application~~applications to account for the Reactive Power losses in the GSU transformer. This is a simple calculation that approximates the stressed system conditions.

For Option 14b, the impedance element ~~is~~shall be set less than the calculated impedance derived from 115 percent of ~~both~~: the Real Power output of 100 percent of the aggregate generation MW capability reported to the Transmission Planner, and ~~the~~ Reactive Power output that equates to 100 percent of the maximum gross Mvar output during field-forcing as determined by simulation. [Option 14b uses the simulated line voltage at the relay location coincident with the highest Reactive Power output achieved during field-forcing in response to a 0.85 per unit of the line nominal voltage at the remote end of the line prior to field-forcing.](#) Using simulation is a more involved, more precise setting of the impedance element overall.

Elements that connect a GSU transformer to the Transmission system that are used exclusively to export energy directly from a BES generating unit or generating plant (Synchronous Generators) Phase Time Overcurrent Relay (e.g., 50 or 51) (Options 15a and 15b)

Relays applied on Elements that connect a GSU transformer to the Transmission system that are used exclusively to export energy directly from a BES generating unit or generating plant are challenged by loading conditions similar to relays applied on generators and GSU transformers. Note that the setting criteria established within ~~these~~the [Table 1](#) options differ from [section 3-9-Chapter 2](#) of the [Considerations for Power Plant and Transmission System Protection Coordination](#) technical reference document. Rather than establishing a uniform setting threshold of 200 percent of the generator nameplate MVA rating at rated power factor for all applications, the setting criteria are based on the maximum expected generator output. Relays applied on the high-side of the GSU transformer respond to the same quantities as the relays ~~connected on~~[the applied at the remote end of the line for](#) Elements that connect a GSU transformer to the Transmission system that are used exclusively to export energy directly from a BES generating unit or generating plant, thus Option 15 is used for these relays as well.

Table 1, Options 15a and 15b, establish criteria for phase [instantaneous and/or](#) time overcurrent relays to prevent Elements that connect a GSU transformer to the Transmission system that are used exclusively to export energy directly from a BES generating unit or generating plant from ~~operating~~tripping during the dynamic conditions anticipated by this standard. The stressed system conditions, anticipated by Option 15a reflects a 0.85 per unit ~~Transmission system of the~~[line nominal voltage at the relay location](#); therefore, establishing that the current value used for applying the Elements that connect a GSU transformer to the Transmission system that are used exclusively to export energy directly from a BES generating unit or generating plant phase [instantaneous and/or](#) time overcurrent relays be calculated from the apparent power addressed

within the criteria, with application of a 0.85 per unit ~~Transmission system of the line nominal voltage at the relay location~~. Consideration of the voltage drop across the GSU transformer is not necessary. Option 15b simulates the line voltage coincident with the highest Reactive Power output achieved during field-forcing in response to a 0.85 per unit ~~nominal voltage on the high-side terminals of the GSU transformer prior to field-forcing~~ line nominal voltage at the remote end of the line prior to field-forcing. Using a 0.85 per unit line nominal voltage at the remote end of the line is representative of the lowest voltage expected during a depressed voltage condition on Elements that are used exclusively to export energy directly from a BES generating unit or generating plant to the Transmission system. Using simulation is a more involved, more precise setting of the overcurrent element overall.

For Option 15a, the overcurrent element ~~is shall be~~ set greater than 115 percent of the calculated current derived from ~~both~~: the Real Power output of 100 percent of the aggregate generation MW capability reported to the Transmission Planner, and ~~the~~ Reactive Power output that equates to 120 percent of the aggregate generation MW value, derived from the generator nameplate MVA rating at rated power factor. This Reactive Power value differs from the 150 percent multiplier used in other ~~application applications~~ to account for the Reactive Power losses in the GSU transformer. This is a simple calculation that approximates the stressed system conditions.

For Option 15b, the overcurrent element ~~is shall be~~ set greater than 115 percent of the calculated current derived from ~~both~~: the Real Power output of 100 percent of the aggregate generation MW capability reported to the Transmission Planner, and ~~the~~ Reactive Power output that equates to 100 percent of the maximum gross Mvar output during field-forcing as determined by simulation. ~~Option 15b uses the simulated line voltage at the relay location coincident with the highest Reactive Power output achieved during field-forcing in response to a 0.85 per unit of the line nominal voltage at the remote end of the line prior to field-forcing~~. Using simulation is a more involved, more precise setting of the overcurrent element overall.

Elements that connect a GSU transformer to the Transmission system that are used exclusively to export energy directly from a BES generating unit or generating plant (Synchronous Generators) Phase Directional ~~Time~~-Overcurrent Relay – Directional Toward Transmission System (e.g., 67) (Options 16a and 16b)

Relays applied on Elements that connect a GSU transformer to the Transmission system that are used exclusively to export energy directly from a BES generating unit or generating plant are challenged by loading conditions similar to relays applied on generators and GSU transformers. Note that the setting criteria established within ~~these~~ ~~the Table 1~~ options differ from ~~section 3.9~~ Chapter 2 of the ~~Considerations for~~ Power Plant and Transmission System Protection Coordination technical reference document. Rather than establishing a uniform setting threshold of 200 percent of the generator nameplate MVA rating at rated power factor for all applications, the setting criteria are based on the maximum expected generator output. Relays applied on the high-side of the GSU transformer respond to the same quantities as the relays ~~connected on~~ ~~the~~ ~~applied at the remote end of the line for~~ Elements that connect a GSU transformer to the

Transmission system that are used exclusively to export energy directly from a BES generating unit or generating plant, thus Option 16 is used for these relays as well.

Table 1, Options 16a and 16b, establish criteria for phase directional ~~time~~ overcurrent relays that are directional toward the Transmission system to prevent Elements that connect a GSU transformer to the Transmission system that are used exclusively to export energy directly from a BES generating unit or generating plant from ~~operating~~ tripping during the dynamic conditions anticipated by this standard. The stressed system conditions, anticipated by Option 16a reflects a 0.85 per unit ~~Transmission system of the line nominal~~ voltage at the relay location; therefore, establishing that the current value used for applying the interconnection Facilities phase directional ~~time~~ overcurrent relays be calculated from the apparent power addressed within the criteria, with application of a 0.85 per unit ~~Transmission system of the line nominal~~ voltage at the relay location. Consideration of the voltage drop across the GSU transformer is not necessary. Option 16b simulates the line voltage coincident with the highest Reactive Power output achieved during field-forcing in response to a 0.85 per unit ~~nominal voltage on the high side terminals of the GSU transformer prior to field forcing~~ line nominal voltage at the remote end of the line prior to field-forcing. Using a 0.85 per unit line nominal voltage at the remote end of the line is representative of the lowest voltage expected during a depressed voltage condition on Elements that are used exclusively to export energy directly from a BES generating unit or generating plant to the Transmission system. Using simulation is a more involved, more precise setting of the overcurrent element overall.

For Option 16a, the overcurrent element ~~is~~ shall be set greater than 115 percent of the calculated current derived from both: the Real Power output of 100 percent of the aggregate generation MW capability reported to the Transmission Planner, and the Reactive Power output that equates to 120 percent of the aggregate generation MW value, derived from the generator nameplate MVA rating at rated power factor. This Reactive Power value differs from the 150 percent multiplier used in other ~~application~~ applications to account for the Reactive Power losses in the GSU transformer. This is a simple calculation that approximates the stressed system conditions.

For Option 16b, the overcurrent element ~~is~~ shall be set greater than 115 percent of the calculated current derived from both: the Real Power output of 100 percent of the aggregate generation MW capability reported to the Transmission Planner, and the Reactive Power output that equates to 100 percent of the maximum gross Mvar output during field-forcing as determined by simulation. Option 16b uses the simulated line voltage at the relay location coincident with the highest Reactive Power output achieved during field-forcing in response to a 0.85 per unit of the line nominal voltage at the remote end of the line prior to field-forcing. Using simulation is a more involved, more precise setting of the overcurrent element overall.

Elements that connect a GSU transformer to the Transmission system that are used exclusively to export energy directly from a BES generating unit or generating plant (Asynchronous Generators) Phase Distance Relay – Directional Toward Transmission System (e.g., 21) (Option 17)

Relays ~~applied on~~ installed on the high-side of the GSU transformer, including relays installed on the remote end of the line, for Elements that connect a GSU transformer to the Transmission system that are used exclusively to export energy directly from a BES generating unit or generating plant are challenged by loading conditions similar to relays applied on generators and GSU transformers. These margins are based on guidance found in ~~section 3.1~~ Chapter 2 of the Considerations for Power Plant and Transmission System Protection Coordination technical reference document.

Table 1, Option 17 establishes criteria for phase distance relays that are directional toward the Transmission system to prevent Elements that connect a GSU transformer to the Transmission system that are used exclusively to export energy directly from a BES generating unit or generating plant from ~~operating~~ tripping during the dynamic conditions anticipated by this standard. Option 17 applies a 1.0 per unit line nominal voltage ~~on~~ at the high-side terminals of the GSU transformer ~~relay location~~ to calculate the impedance from the maximum aggregate nameplate MVA. ~~Asynchronous generators do not produce as much Reactive Power as synchronous generators; the voltage drop due to Reactive Power flow through the GSU transformer is not as significant.~~

For Option 17, the impedance element ~~is~~ shall be set less than the calculated impedance derived from 130 percent of the maximum aggregate nameplate MVA output at rated power factor including the Mvar output of any static or dynamic Reactive Power devices. This is determined by summing the total MW and Mvar capability of the generation equipment behind the relay and any static or dynamic Reactive Power devices that contribute to the power flow through the relay. This is a simple calculation that approximates the stressed system conditions.

Elements that connect a GSU transformer to the Transmission system that are used exclusively to export energy directly from a BES generating unit or generating plant (Asynchronous Generators) Phase ~~Time~~ Overcurrent Relay (e.g., 50 and 51) (Option 18)

Relays ~~applied on~~ installed on the high-side of the GSU transformer, including relays installed on the remote end of the line, for Elements that connect a GSU transformer to the Transmission system that are used exclusively to export energy directly from a BES generating unit or generating plant are challenged by loading conditions similar to relays applied on generators and GSU transformers. Note that the setting criteria established within ~~these~~ the Table 1 options differ from section 3.9 ~~Chapter 2~~ of the Considerations for Power Plant and Transmission System Protection Coordination technical reference document. Rather than establishing a uniform setting threshold of 200 percent of the generator nameplate MVA rating at rated power factor for all applications, the setting criteria are based on the maximum expected generator output.

Table 1, Option 18 establishes criteria for phase ~~time~~ overcurrent relays to prevent Elements that connect a GSU transformer to the Transmission system that are used exclusively to export energy

directly from a BES generating unit or generating plant from ~~operating tripping~~ during the dynamic conditions anticipated by this standard. Option 18 applies a 1.0 per unit ~~line~~ nominal voltage ~~on~~at the ~~high-side terminals~~location of the ~~GSU transformer~~relay to calculate the current from the maximum aggregate nameplate MVA. ~~Asynchronous generators do not produce as much Reactive Power as synchronous generators; the voltage drop due to Reactive Power flow through the GSU transformer is not as significant.~~

For Option 18, the overcurrent element ~~is~~shall be set greater than 130 percent of the calculated current derived from the maximum aggregate nameplate MVA output at rated power factor including the Mvar output of any static or dynamic Reactive Power devices. This is determined by summing the total MW and Mvar capability of the generation equipment behind the relay and any static or dynamic Reactive Power devices that contribute to the power flow through the relay. This is a simple calculation that approximates the stressed system conditions.

Elements that connect a GSU transformer to the Transmission system that are used exclusively to export energy directly from a BES generating unit or generating plant (Asynchronous Generators) Phase Directional ~~Time~~ Overcurrent Relay – Directional Toward Transmission System (e.g., 67) (Option 19)

Relays ~~applied on~~installed on the high-side of the GSU transformer, including relays installed on the remote end of the line, for Elements that connect a GSU transformer to the Transmission system that are used exclusively to export energy directly from a BES generating unit or generating plant are challenged by loading conditions similar to relays applied on generators and GSU transformers. Note that the setting criteria established within ~~these~~the Table 1 options differ from ~~section 3.9~~Chapter 2 of the ~~Considerations for~~ Power Plant and Transmission System Protection Coordination technical reference document. Rather than establishing a uniform setting threshold of 200 percent of the generator nameplate MVA rating at rated power factor for all applications, the setting criteria are based on the maximum expected generator output.

Table 1, Option 19 establishes criteria for phase directional-~~time~~ overcurrent relays that are directional toward the Transmission system to prevent Elements that connect a GSU transformer to the Transmission system that are used exclusively to export energy directly from a BES generating unit or generating plant from ~~operating tripping~~ during the dynamic conditions anticipated by this standard. Option 19 applies a 1.0 per unit ~~line~~ nominal voltage ~~on~~at the ~~high-side terminals of the GSU transformer~~relay location to calculate the current from the maximum aggregate nameplate MVA. ~~Asynchronous generators do not produce as much Reactive Power as synchronous generators; the voltage drop due to Reactive Power flow through the GSU transformer is not as significant.~~

For Option 19, the overcurrent element ~~is~~shall be set greater than 130 percent of the calculated current derived from the maximum aggregate nameplate MVA output at rated power factor including the Mvar output of any static or dynamic Reactive Power devices. This is determined by summing the total MW and Mvar capability of the generation equipment behind the relay and any static or dynamic Reactive Power devices that contribute to the power flow through the relay. This is a simple calculation that approximates the stressed system conditions.

Example Calculations

Introduction

Example Calculations.	
Input Descriptions	Input Values
Synchronous Generator nameplate (MVA @ rated pf):	$GEN_{Synch_nameplate} = 903 \text{ MVA}$
	$pf = 0.85$
Generator rated voltage (Line-to-Line):	$V_{gen_nom} = 22 \text{ kV}$
Real Power output in MW as reported to the TP:	$P_{Synch_reported} = 700.0 \text{ MW}$
Generator step-up (GSU) transformer rating:	$MVA_{GSU} = 903 \text{ MVA}$
GSU transformer reactance (903 MVA base):	$X_{GSU} = 12.14\%$
GSU transformer MVA base:	$MVA_{base} = 767.6 \text{ MVA}$
GSU transformer turns ratio:	$GSU_{ratio} = \frac{22 \text{ kV}}{346.5 \text{ kV}}$
High-side nominal system voltage (Line-to-Line):	$V_{nom} = 345 \text{ kV}$
Current transformer (CT) ratio:	$CT_{ratio} = \frac{25000}{5}$
Potential transformer (PT) ratio low-side:	$PT_{ratio} = \frac{200}{1}$
PT ratio high-side:	$PT_{ratio_hv} = \frac{2000}{1}$
Unit auxiliary transformer (UAT) nameplate:	$UAT_{nameplate} = 60 \text{ MVA}$
UAT low high-side voltage:	$V_{UAT} = 13.8 \text{ kV}$
UAT CT ratio:	$CT_{UAT} = \frac{5000}{5}$
CT high voltage ratio:	$CT_{ratio_hv} = \frac{2000}{5}$
Reactive Power output of static reactive device:	$MVAR_{static} = 15 \text{ Mvar}$

Example Calculations.	
Reactive Power output of static reactive device generation:	$MVAR_{gen_static} = 5 \text{ Mvar}$
Asynchronous generator nameplate (MVA @ rated pf):	$GEN_{Asynch_nameplate} = 40 \text{ MVA}$
	$pf = 0.85$
Asynchronous CT ratio:	$CT_{Asynch_ratio} = \frac{5000}{5}$
Asynchronous high voltage CT ratio:	$CT_{Asynch_ratio_hv} = \frac{300}{5}$
CT remote substation bus	$CT_{ratio_remote_bus} = \frac{2000}{5}$

Example Calculations: Option 1a

Option 1a represents the simplest calculation for synchronous generators applying a phase distance relay (e.g., 21) directional toward the Transmission system.

Real Power output (P):

$$\text{Eq. (1)} \quad P = GEN_{Synch_nameplate} \times pf$$

$$P = 903 \text{ MVA} \times 0.85$$

$$P = 767.6 \text{ MW}$$

Reactive Power output (Q):

$$\text{Eq. (2)} \quad Q = 150\% \times P$$

$$Q = 1.50 \times 767.6 \text{ MW}$$

$$Q = 1151.3 \text{ Mvar}$$

Option 1a, Table 1 – Bus Voltage, calls for a 0.95 per unit of the high-side nominal voltage for the generator bus voltage (V_{gen}):

$$\text{Eq. (3)} \quad V_{gen} = 0.95 \text{ p. u.} \times V_{nom} \times GSR_{ratio}$$

$$V_{gen} = 0.95 \times 345 \text{ kV} \times \left(\frac{22 \text{ kV}}{346.5 \text{ kV}} \right)$$

$$V_{gen} = 20.81 \text{ kV}$$

Apparent power (S):

$$\text{Eq. (4)} \quad S = P_{Synch_reported} + jQ$$

$$S = 700.0 \text{ MW} + j1151.3 \text{ Mvar}$$

$$S = 1347.4 \angle 58.7^\circ \text{ MVA}$$

Primary impedance (Z_{pri}):

$$\text{Eq. (5)} \quad Z_{pri} = \frac{V_{gen}^2}{S^*}$$

$$Z_{pri} = \frac{(20.81 \text{ kV})^2}{1347.4 \angle -58.7^\circ \text{ MVA}}$$

Example Calculations: Option 1a

$$Z_{pri} = 0.321 \angle 58.7^\circ \Omega$$

Secondary impedance (Z_{sec}):

$$\text{Eq. (6)} \quad Z_{sec} = Z_{pri} \times \frac{CT_{ratio}}{PT_{ratio}}$$

$$Z_{sec} = 0.321 \angle 58.7^\circ \Omega \times \frac{\frac{25000}{5}}{\frac{200}{1}}$$

$$Z_{sec} = 0.321 \angle 58.7^\circ \Omega \times 25$$

$$Z_{sec} = 8.035 \angle 58.7^\circ \Omega$$

To satisfy the 115% margin in Option 1a:

$$\text{Eq. (7)} \quad Z_{sec\ limit} = \frac{Z_{sec}}{115\%}$$

$$Z_{sec\ limit} = \frac{8.035 \angle 58.7^\circ \Omega}{1.15}$$

$$Z_{sec\ limit} = 6.9873 \angle 58.7^\circ \Omega$$

$$\theta_{transient\ load\ angle} = 58.7^\circ$$

Assume a Mho distance impedance relay with a maximum torque angle (MTA) set at 85° to 85° then the maximum allowable impedance reach is:

$$\text{Eq. (8)} \quad Z_{max} < \frac{|Z_{sec\ limit}|}{\cos(\theta_{MTA} - \theta_{transient\ load\ angle})}$$

$$Z_{max} < \frac{6.9873 \Omega}{\cos(85.0^\circ - 58.7^\circ)}$$

$$Z_{max} < \frac{6.9873 \Omega}{0.896}$$

$$Z_{max} < 7.793 \angle 85.0^\circ \Omega$$

Example Calculations: Options 1b and 7b

Option 1b represents a more complex, more precise calculation for synchronous generators applying a phase distance relay (e.g., 21) directional toward the Transmission system. This option requires calculating low-side voltage taking into account voltage drop across the GSU transformer. Similarly these calculations may be applied to Option 7b for GSU transformers applying a phase distance relay (e.g., 21) directional toward the Transmission system.

Real Power output (P):

$$\text{Eq. (9)} \quad P = GEN_{Synch_nameplate} \times pf$$

$$P = 903 \text{ MVA} \times 0.85$$

$$P = 767.6 \text{ MW}$$

Reactive Power output (Q):

$$\text{Eq. (10)} \quad Q = 150\% \times P$$

$$Q = 1.50 \times 767.6 \text{ MW}$$

$$Q = 1151.3 \text{ Mvar}$$

Convert Real Power, Reactive Power, and transformer reactance to per unit values on a 767.6 MVA base (MVA_{base}):

Real Power output (P):

$$\text{Eq. (11)} \quad P_{pu} = \frac{P_{Synch_reported}}{MVA_{base}}$$

$$P_{pu} = \frac{700.0 \text{ MW}}{767.6 \text{ MVA}}$$

$$P_{pu} = 0.91 \text{ p.u.}$$

Reactive Power output (Q):

$$\text{Eq. (12)} \quad Q_{pu} = \frac{Q}{MVA_{base}}$$

$$Q_{pu} = \frac{1151.3 \text{ Mvar}}{767.6 \text{ MVA}}$$

$$Q_{pu} = 1.5 \text{ p.u.}$$

Example Calculations: Options 1b and 7b

Transformer impedance (X_{pu}):

$$\text{Eq. (13)} \quad X_{pu} = X_{GSU(Old)} \times \left(\frac{MVA_{base}}{MVA_{GSU}} \right)$$

$$X_{pu} = 12.14\% \times \left(\frac{767.6 \text{ MVA}}{903 \text{ MVA}} \right)$$

$$X_{pu} = 0.1032 \text{ p. u.}$$

Using the formula below; calculate the low-side GSU transformer voltage ($V_{low-side}$) using 0.85 p.u. high-side voltage ($V_{high-side}$). **Estimate/Assume** initial low-side voltage to be 0.95 p.u. and repeat the calculation as necessary until $V_{low-side}$ converges. A convergence of less than one percent (<1%) between iterations is considered sufficient:

$$\text{Eq. (14)} \quad \theta_{low-side} = \sin^{-1} \left[\frac{(P_{pu} \times |X_{pu}|)}{(|V_{low-side}| \times |V_{high-side}|)} \right]$$

$$\theta_{low-side} = \sin^{-1} \left[\frac{(0.91 \times 0.1032)}{(0.95 \times 0.85)} \right]$$

$$\theta_{low-side} = 6.7^\circ$$

[Eq. \(15\)](#)

$$\text{Eq. (15)} \quad |V_{low-side}| = \frac{|V_{high-side}| \times \cos(\theta_{low-side}) \pm \sqrt{|V_{high-side}|^2 \times \cos^2(\theta_{low-side}) + 4 \times Q_{pu} \times X_{pu}}}{2}$$

$$|V_{low-side}| = \frac{|0.85| \times \cos(6.7^\circ) \pm \sqrt{|0.85|^2 \times \cos^2(6.7^\circ) + 4 \times 1.5 \times 0.1032}}{2}$$

$$|V_{low-side}| = \frac{|0.85| \times 0.9931 \pm \sqrt{0.7225 \times 0.9864 + 0.6192}}{2}$$

$$|V_{low-side}| = \frac{0.8441 \pm 1.1541}{2}$$

$$|V_{low-side}| = 0.9991 \text{ p. u.}$$

Deleted Cells

Example Calculations: Options 1b and 7b

Use the new estimated $V_{low-side}$ value of 0.9991 per unit for the second iteration:

$$\text{Eq. (16)} \quad \theta_{low-side} = \sin^{-1} \left[\frac{(P_{pu} \times |X_{pu}|)}{(|V_{low-side}| \times |V_{high-side}|)} \right]$$

$$\theta_{low-side} = \sin^{-1} \left[\frac{(0.91 \times 0.1032)}{(0.9991 \times 0.85)} \right]$$

$$\theta_{low-side} = 6.3^\circ$$

Eq. (17)

$$\text{Eq. (17)} \quad |V_{low-side}| = \frac{|V_{high-side}| \times \cos(\theta_{low-side}) \pm \sqrt{|V_{high-side}|^2 \times \cos^2(\theta_{low-side}) + 4 \times Q_{pu} \times X_{pu}}}{2}$$

$$|V_{low-side}| = \frac{0.85 \times \cos(6.3^\circ) \pm \sqrt{0.85^2 \times \cos^2(6.3^\circ) + 4 \times 1.5 \times 0.1032}}{2}$$

$$|V_{low-side}| = \frac{0.8449 \pm 1.1546}{2}$$

$$|V_{low-side}| = \frac{0.8449 \pm 1.1546}{2}$$

$$|V_{low-side}| = 0.9998 \text{ p.u.}$$

To account for system high-side nominal voltage and the transformer tap ratio:

$$\text{Eq. (18)} \quad V_{bus} = |V_{low-side}| \times V_{nom} \times GSU_{ratio}$$

$$V_{bus} = 0.9998 \text{ p.u.} \times 345 \text{ kV} \times \left(\frac{22 \text{ kV}}{346.5 \text{ kV}} \right)$$

$$V_{bus} = 21.90 \text{ kV}$$

Apparent power (S):

$$\text{Eq. (19)} \quad S = P_{Synch_reported} + jQ$$

$$S = 700.0 \text{ MW} + j1151.3 \text{ Mvar}$$

$$S = 1347.4 \angle 58.7^\circ \text{ MVA}$$

Deleted Cells

Example Calculations: Options 1b and 7b

Primary impedance (Z_{pri}):

$$\text{Eq. (20)} \quad Z_{pri} = \frac{V_{bus}^2}{S^*}$$

$$Z_{pri} = \frac{(21.90 \text{ kV})^2}{1347.4 \angle -58.7^\circ \text{ MVA}}$$

$$Z_{pri} = 0.356 \angle 58.7^\circ \Omega$$

Secondary impedance (Z_{sec}):

$$\text{Eq. (21)} \quad Z_{sec} = Z_{pri} \times \frac{CT_{ratio}}{PT_{ratio}}$$

$$Z_{sec} = 0.356 \angle 58.7^\circ \Omega \times \frac{\frac{25000}{5}}{\frac{200}{1}}$$

$$Z_{sec} = 0.356 \angle 58.7^\circ \Omega \times 25$$

$$Z_{sec} = 8.900 \angle 58.7^\circ \Omega$$

To satisfy the 115% margin in Options 1b and 7b:

$$\text{Eq. (22)} \quad Z_{sec \text{ limit}} = \frac{Z_{sec}}{115\%}$$

$$Z_{sec \text{ limit}} = \frac{8.900 \angle 58.7^\circ \Omega}{1.15}$$

$$Z_{sec \text{ limit}} = 7.74 \angle 58.7^\circ \Omega$$

$$\theta_{\text{transient load angle}} = 58.7^\circ$$

Assume a Mho distance impedance relay with a maximum torque angle (MTA) set at 85° , then the maximum allowable impedance reach is:

$$\text{Eq. (23)} \quad Z_{max} < \frac{|Z_{sec \text{ limit}}|}{\cos(\theta_{MTA} - \theta_{\text{transient load angle}})}$$

$$Z_{max} < \frac{7.74 \Omega}{\cos(85.0^\circ - 58.7^\circ)}$$

Example Calculations: Options 1b and 7b

$$Z_{max} < \frac{7.74 \Omega}{0.8965}$$

$$Z_{max} < 8.633 \angle 85.0^\circ \Omega$$

Example Calculations: Options 1c and 7c

Option 1c represents a more involved, more precise setting of the impedance element. This option requires determining maximum generator Reactive Power output during field-forcing and the corresponding generator bus voltage. Once these values are determined, the remainder of the calculation is the same as Options 1a and 1b.

The generator Reactive Power and generator bus voltage are determined by simulation. The maximum Reactive Power output on the low-side of the GSU transformer during field-forcing is used as this value will correspond to the lowest apparent impedance. The corresponding generator bus voltage is also used in the calculation. Note that although the excitation limiter reduces the field, the duration of the Reactive Power output achieved for this condition is sufficient to operate a phase distance relay.

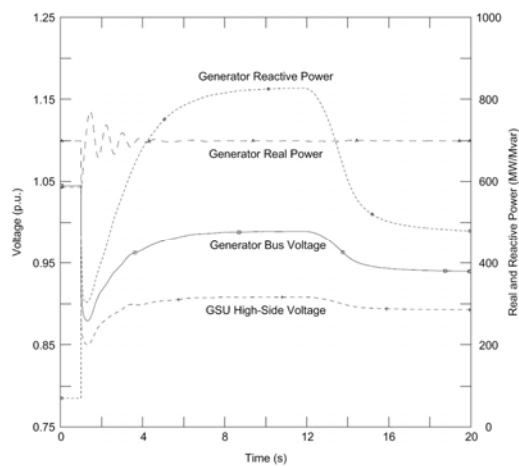

~~The generator Reactive Power and generator bus voltage are determined by simulation. The maximum Reactive Power output on the low-side of the GSU transformer during field forcing is used as this value will correspond to the lowest apparent impedance. The corresponding generator bus voltage is also used in the calculation. Note that although the excitation limiter reduces the field, the duration of the Reactive Power output achieved for this condition is sufficient to operate a phase distance relay.~~

In this simulation the following values are derived:

$$Q = 827.4 \text{ Mvar}$$

$$V_{bus_simulated} = 0.989 \times V_{gen_nom} = 21.76 \text{ kV}$$

Example Calculations: Options 1c and 7c

The other value required is the Real Power output which is modeled in the simulation at 100% of the gross MW capability reported to the Transmission Planner. In this case:

$$P_{Synch_reported} = 700.0 \text{ MW}$$

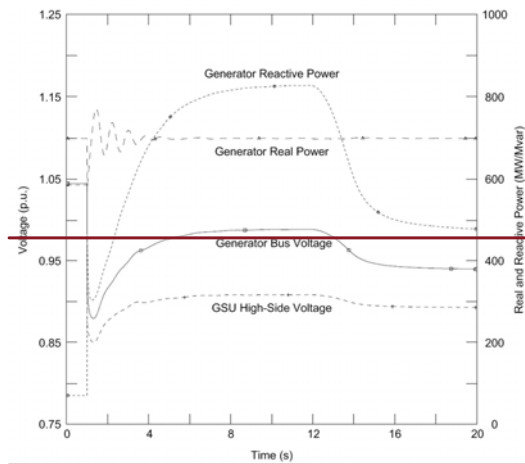

Apparent power (S):

$$\text{Eq. (24)} \quad S = P_{Synch_reported} + jQ$$

$$S = 700.0 \text{ MW} + j827.4 \text{ Mvar}$$

$$S = 1083.8 \angle 49.8^\circ \text{ MVA}$$

Primary impedance (Z_{pri}):

$$\text{Eq. (25)} \quad Z_{pri} = \frac{V_{bus_simulated}^2}{S^*}$$

$$Z_{pri} = \frac{(21.76 \text{ kV})^2}{1083.8 \angle -49.8^\circ \text{ MVA}}$$

$$Z_{pri} = 0.437 \angle 49.8^\circ \Omega$$

Example Calculations: Options 1c and 7c

Secondary impedance (Z_{sec}):

$$\begin{aligned}\text{Eq. (26)} \quad Z_{sec} &= Z_{pri} \times \frac{CT_{ratio}}{PT_{ratio}} \\ Z_{sec} &= 0.437 \angle 49.8^\circ \Omega \times \frac{25000}{\frac{200}{1}} \\ Z_{sec} &= 0.437 \angle 49.8^\circ \Omega \times 25 \\ Z_{sec} &= 10.92 \angle 49.8^\circ \Omega\end{aligned}$$

To satisfy the 115% margin in the requirement in Options 1c and 7c:

$$\begin{aligned}\text{Eq. (27)} \quad Z_{sec\ limit} &= \frac{Z_{sec}}{115\%} \\ Z_{sec\ limit} &= \frac{10.92 \angle 49.8^\circ \Omega}{1.15} \\ Z_{sec\ limit} &= 9.50 \angle 49.8^\circ \Omega \\ \theta_{transient\ load\ angle} &= 49.8^\circ\end{aligned}$$

Assume a Mho distance impedance relay with a maximum torque angle (MTA) set at 85° , then the maximum allowable impedance reach is:

$$\begin{aligned}\text{Eq. (28)} \quad Z_{max} &< \frac{|Z_{sec\ limit}|}{\cos(\theta_{MTA} - \theta_{transient\ load\ angle})} \\ Z_{max} &< \frac{9.50 \Omega}{\cos(85.0^\circ - 49.8^\circ)} \\ Z_{max} &< \frac{9.50 \Omega}{0.8171} \\ Z_{max} &< 11.63 \angle 85.0^\circ \Omega\end{aligned}$$

Example Calculations: Option 2a

Option 2a represents the simplest calculation for synchronous generators applying a phase ~~time~~ overcurrent (e.g., 50, 51, or 51V-R – voltage restrained) ~~voltage restrained~~ relay:

Real Power output (P):

$$\text{Eq. (29)} \quad P = GEN_{Synchron_nameplate} \times pf$$

$$P = 903 \text{ MVA} \times 0.85$$

$$P = 767.6 \text{ MW}$$

Reactive Power output (Q):

$$\text{Eq. (30)} \quad Q = 150\% \times P$$

$$Q = 1.50 \times 767.6 \text{ MW}$$

$$Q = 1151.3 \text{ Mvar}$$

Option 2a, Table 1 – Bus Voltage, calls for a 0.95 per unit of the high-side nominal voltage for the generator bus voltage (V_{gen}):

$$\text{Eq. (31)} \quad V_{gen} = 0.95 \text{ p.u.} \times V_{nom} \times G\text{SU}_{ratio}$$

$$V_{gen} = 0.95 \times 345 \text{ kV} \times \left(\frac{22 \text{ kV}}{346.5 \text{ kV}} \right)$$

$$V_{gen} = 20.81 \text{ kV}$$

Apparent power (S):

$$\text{Eq. (32)} \quad S = P_{Synchron_reported} + jQ$$

$$S = 700.0 \text{ MW} + j1151.3 \text{ Mvar}$$

$$S = 1347.4 \angle 58.7^\circ \text{ MVA}$$

Primary current (I_{pri}):

$$\text{Eq. (33)} \quad I_{pri} = \frac{S}{\sqrt{3} \times V_{gen}}$$

$$I_{pri} = \frac{1347.4 \text{ MVA}}{1.73 \times 20.81 \text{ kV}}$$

Example Calculations: Option 2a

$$I_{pri} = 37383 \text{ A}$$

Secondary current (I_{sec}):

$$\text{Eq. (34)} \quad I_{sec} = \frac{I_{pri}}{CT_{ratio}}$$

$$I_{sec} = \frac{37383 \text{ A}}{\frac{25000}{5}}$$

$$I_{sec} = 7.477 \text{ A}$$

To satisfy the 115% margin in Option 2a:

$$\text{Eq. (35)} \quad I_{sec \text{ limit}} > I_{sec} \times 115\%$$

$$I_{sec \text{ limit}} > 7.477 \text{ A} \times 1.15$$

$$I_{sec \text{ limit}} > 8.598 \text{ A}$$

Example Calculations: Option 2b

Option 2b represents a more complex calculation for synchronous generators applying a phase ~~time~~ overcurrent (e.g., 50, 51, or 51V-R – ~~voltage restrained~~ ~~voltage-restrained~~ relay):

Real Power output (P):

$$\text{Eq. (36)} \quad P = GEN_{synch_nameplate} \times pf$$

$$P = 903 \text{ MVA} \times 0.85$$

$$P = 767.6 \text{ MW}$$

Reactive Power output (Q):

$$\text{Eq. (37)} \quad Q = 150\% \times P$$

$$Q = 1.50 \times 767.6 \text{ MW}$$

$$Q = 1151.3 \text{ Mvar}$$

Example Calculations: Option 2b

Convert Real Power, Reactive Power, and transformer reactance to per unit values on 767.6 MVA base (MVA_{base}).

Real Power output (P):

$$\text{Eq. (38)} \quad P_{pu} = \frac{P_{Synchron_reported}}{MVA_{base}}$$

$$P_{pu} = \frac{700.0 \text{ MW}}{767.6 \text{ MVA}}$$

$$P_{pu} = 0.91 \text{ p.u.}$$

Reactive Power output (Q):

$$\text{Eq. (39)} \quad Q_{pu} = \frac{Q}{MVA_{base}}$$

$$Q_{pu} = \frac{1151.3 \text{ Mvar}}{767.6 \text{ MVA}}$$

$$Q_{pu} = 1.5 \text{ p.u.}$$

Transformer impedance:

$$\text{Eq. (40)} \quad X_{pu} = X_{GSU(oid)} \times \frac{MVA_{base}}{MVA_{GSU}}$$

$$X_{pu} = 12.14\% \times \left(\frac{767.6 \text{ MVA}}{903 \text{ MVA}} \right)$$

$$X_{pu} = 0.1032 \text{ p.u.}$$

Using the formula below; calculate the low-side GSU transformer voltage ($V_{low-side}$) using 0.85 p.u. high-side voltage ($V_{high-side}$). **Estimate Assume** initial low-side voltage to be 0.95 p.u. and repeat the calculation as necessary until $V_{low-side}$ converges. A convergence of less than one percent (<1%) between iterations is considered sufficient:

$$\text{Eq. (41)} \quad \theta_{low-side} = \sin^{-1} \left[\frac{(P_{pu} \times |X_{pu}|)}{(|V_{low-side}| \times |V_{high-side}|)} \right]$$

$$\theta_{low-side} = \sin^{-1} \left[\frac{(0.91 \times 0.1032)}{(0.95 \times 0.85)} \right]$$

Example Calculations: Option 2b

$$\theta_{low-side} = 6.7^\circ$$

$$\text{Eq. (42)} \quad |V_{low-side}| = \frac{|V_{high-side}| \times \cos(\theta_{low-side}) \pm \sqrt{|V_{high-side}|^2 \times \cos^2(\theta_{low-side}) + 4 \times Q_{pu} \times X_{pu}}}{2}$$

$$|V_{low-side}| = \frac{|0.85| \times \cos(6.7^\circ) \pm \sqrt{|0.85|^2 \times \cos^2(6.7^\circ) + 4 \times 1.5 \times 0.1032}}{2}$$

$$|V_{low-side}| = \frac{|0.85| \times 0.9931 \pm \sqrt{0.7225 \times 0.9864 + 0.6192}}{2}$$

$$|V_{low-side}| = \frac{0.8441 \pm 1.1541}{2}$$

$$|V_{low-side}| = 0.9991 \text{ p.u.}$$

Use the new estimated $V_{low-side}$ value of 0.9991 per unit for the second iteration:

$$\text{Eq. (43)} \quad \theta_{low-side} = \sin^{-1} \left[\frac{(P_{pu} \times |X_{pu}|)}{(|V_{low-side}| \times |V_{high-side}|)} \right]$$

$$\theta_{low-side} = \sin^{-1} \left[\frac{(0.91 \times 0.1032)}{(0.9991 \times 0.85)} \right]$$

$$\theta_{low-side} = 6.3^\circ$$

$$\text{Eq. (44)} \quad |V_{low-side}| = \frac{|V_{high-side}| \times \cos(\theta_{low-side}) \pm \sqrt{|V_{high-side}|^2 \times \cos^2(\theta_{low-side}) + 4 \times Q_{pu} \times X_{pu}}}{2}$$

$$|V_{low-side}| = \frac{|0.85| \times \cos(6.3^\circ) \pm \sqrt{|0.85|^2 \times \cos^2(6.3^\circ) + 4 \times 1.5 \times 0.1032}}{2}$$

$$|V_{low-side}| = \frac{|0.85| \times 0.9940 \pm \sqrt{0.7225 \times 0.9880 + 0.6192}}{2}$$

$$|V_{low-side}| = \frac{0.8449 \pm 1.1546}{2}$$

$$|V_{low-side}| = 0.9998 \text{ p.u.}$$

Example Calculations: Option 2b

To account for system high-side nominal voltage and the transformer tap ratio:

$$\text{Eq. (45)} \quad V_{bus} = |V_{low-side}| \times V_{nom} \times GSU_{ratio}$$

$$V_{bus} = 0.9998 \text{ p.u.} \times 345 \text{ kV} \times \left(\frac{22 \text{ kV}}{346.5 \text{ kV}} \right)$$

$$V_{bus} = 21.90 \text{ kV}$$

Apparent power (S):

$$\text{Eq. (46)} \quad S = P_{Synch_reported} + jQ$$

$$S = 700.0 \text{ MW} + j1151.3 \text{ Mvar}$$

$$S = 1347.4 \angle 58.7^\circ \text{ MVA}$$

Primary current (I_{pri}):

$$\text{Eq. (47)} \quad I_{pri} = \frac{S}{\sqrt{3} \times V_{bus}}$$

$$I_{pri} = \frac{1347.4 \text{ MVA}}{1.73 \times 21.90 \text{ kV}}$$

$$I_{pri} = 35553 \text{ A}$$

Secondary current (I_{sec}):

$$\text{Eq. (48)} \quad I_{sec} = \frac{I_{pri}}{CT_{ratio}}$$

$$I_{sec} = \frac{35553 \text{ A}}{\frac{25000}{5}}$$

$$I_{sec} = 7.111 \text{ A}$$

To satisfy the 115% margin in Option 2b:

$$\text{Eq. (49)} \quad I_{sec\ limit} > I_{sec} \times 115\%$$

Example Calculations: Option 2b

$$I_{sec\ limit} > 7.111\ A \times 1.15$$

$$I_{sec\ limit} > 8.178\ A$$

Example Calculations: Option 2c

Option 2c represents a more involved, more precise setting of the overcurrent element for the phase time overcurrent (51V-R) voltage restrained relay. This option requires determining maximum generator Reactive Power output during field-forcing and the corresponding generator bus voltage. Once these values are determined, the remainder of the calculation is the same as Options 2a and 2b.

The generator Reactive Power and generator bus voltage are determined by simulation. The maximum Reactive Power output on the low-side of the GSU transformer during field-forcing is used as this value will correspond to the highest current. The corresponding generator bus voltage is also used in the calculation. Note that although the excitation limiter reduces the field, the duration of the Reactive Power output achieved for this condition is sufficient to operate a voltage-restrained phase overcurrent relay.

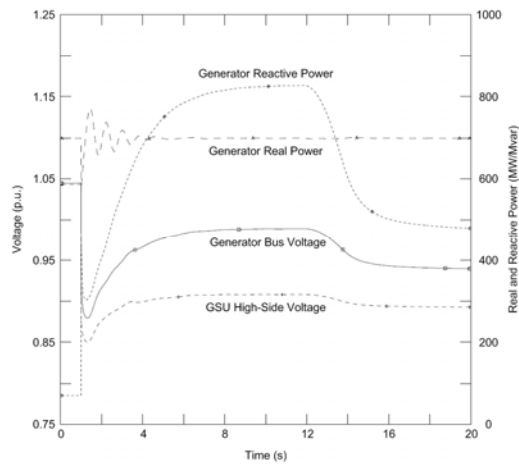

Example Calculations: Option 2c

The generator Reactive Power and generator bus voltage are determined by simulation. The maximum Reactive Power output on the low side of the GSU transformer during field forcing is used as this value will correspond to the highest current. The corresponding generator bus voltage is also used in the calculation. Note that although the excitation limiter reduces the field, the duration of the Reactive Power output achieved for this condition is sufficient to operate a voltage-restrained phase-overcurrent relay.

In this simulation the following values are derived:

$$Q = 827.4 \text{ Mvar}$$

$$V_{bus_simulated} = 0.989 \times V_{gen_nom} = 21.76 \text{ kV}$$

The other value required is the Real Power output which is modeled in the simulation at 100% of the gross MW capability reported to the Transmission Planner. In this case:

$$P_{Synch_reported} = 700.0 \text{ MW}$$

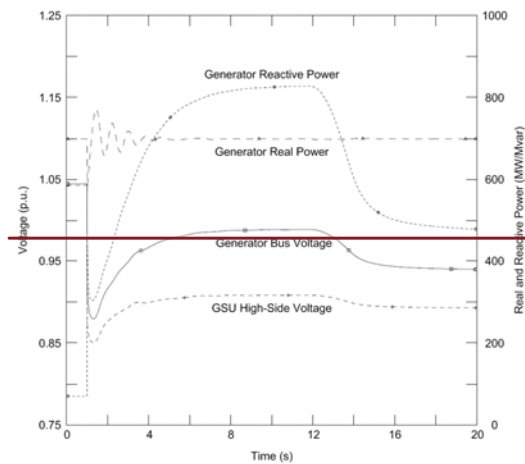

Apparent power (S):

$$\text{Eq. (50)} \quad S = P_{Synch_reported} + jQ$$

$$S = 700.0 \text{ MW} + j827.4 \text{ Mvar}$$

$$S = 1083.8 \angle 49.8^\circ \text{ MVA}$$

Example Calculations: Option 2c

Primary current (I_{pri}):

$$\text{Eq. (51)} \quad I_{pri} = \frac{S}{\sqrt{3} \times V_{bus_simulated}}$$

$$I_{pri} = \frac{1083.8 \text{ MVA}}{1.73 \times 21.76 \text{ kV}}$$

$$I_{pri} = 28790 \text{ A}$$

Secondary current (I_{sec}):

$$\text{Eq. (52)} \quad I_{sec} = \frac{I_{pri}}{CT_{ratio}}$$

$$I_{sec} = \frac{28790 \text{ A}}{\frac{25000}{5}}$$

$$I_{sec} = 5.758 \text{ A}$$

To satisfy the 115% margin in Option 2c:

$$\text{Eq. (53)} \quad I_{sec \text{ limit}} > I_{sec} \times 115\%$$

$$I_{sec \text{ limit}} > 5.758 \text{ A} \times 1.15$$

$$I_{sec \text{ limit}} > 6.622 \text{ A}$$

Example Calculations: Options 3 and 6

Option 3 represents the only calculation for synchronous generators applying a phase time overcurrent (e.g., 51V-C) ~~voltage controlled~~ relay (Enabled to operate as a function of voltage). Similarly, Option 6 uses the same calculation for asynchronous generators.

Options 3 and 6, Table 1 – Bus Voltage, calls for a 1.0 per unit of the high-side nominal voltage for the generator bus voltage (V_{gen}):

$$\text{Eq. (54)} \quad V_{gen} = 1.0 \text{ p. u.} \times V_{nom} \times GSU_{ratio}$$

$$V_{gen} = 1.0 \times 345 \text{ kV} \times \left(\frac{22 \text{ kV}}{346.5 \text{ kV}} \right)$$

Example Calculations: Options 3 and 6

$$V_{gen} = 21.9 \text{ kV}$$

The voltage setting shall be set less than 75% of the generator bus voltage:

$$\text{Eq. (55)} \quad V_{setting} < V_{gen} \times 75\%$$

$$V_{setting} < 21.9 \text{ kV} \times 0.75$$

$$V_{setting} < 16.429 \text{ kV}$$

Example Calculations: Option 4

This represents the calculation for an asynchronous generator (including inverter-based installations) applying a phase distance relay ([e.g., 21](#)) – directional toward the Transmission system.

Real Power output (P):

$$\text{Eq. (56)} \quad P = GEN_{Asynch_nameplate} \times pf$$

$$P = 40 \text{ MVA} \times 0.85$$

$$P = 34.0 \text{ MW}$$

Reactive Power output (Q):

$$\text{Eq. (57)} \quad Q = GEN_{Asynch_nameplate} \times \sin(\cos^{-1}(pf))$$

$$Q = 40 \text{ MVA} \times \sin(\cos^{-1}(0.85))$$

$$Q = 21.1 \text{ Mvar}$$

Option 4, Table 1 – Bus Voltage, calls for a 1.0 per unit of the high-side nominal voltage for the generator bus voltage (V_{gen}):

$$\text{Eq. (58)} \quad V_{gen} = 1.0 \text{ p. u.} \times V_{nom} \times GSU_{ratio}$$

$$V_{gen} = 1.0 \times 345 \text{ kV} \times \left(\frac{22 \text{ kV}}{346.5 \text{ kV}} \right)$$

$$V_{gen} = 21.9 \text{ kV}$$

Example Calculations: Option 4

Apparent power (S):

$$\text{Eq. (59)} \quad S = P + jQ$$

$$S = 34.0 \text{ MW} + j21.1 \text{ Mvar}$$

$$S = 40.0 \angle 31.8^\circ \text{ MVA}$$

Primary impedance (Z_{pri}):

$$\text{Eq. (60)} \quad Z_{pri} = \frac{V_{gen}^2}{S^*}$$

$$Z_{pri} = \frac{(21.9 \text{ kV})^2}{40.0 \angle -31.8^\circ \text{ MVA}}$$

$$Z_{pri} = 11.99 \angle 31.8^\circ \Omega$$

Secondary impedance (Z_{sec}):

$$\text{Eq. (61)} \quad Z_{sec} = Z_{pri} \times \frac{CT_{Asynch_ratio}}{PT_{ratio}}$$

$$Z_{sec} = 11.99 \angle 31.8^\circ \Omega \times \frac{5000}{\frac{5}{200}} \frac{1}{1}$$

$$Z_{sec} = 11.99 \angle 31.8^\circ \Omega \times 5$$

$$Z_{sec} = 59.95 \angle 31.8^\circ \Omega$$

To satisfy the 130% margin in Option 4:

$$\text{Eq. (62)} \quad Z_{sec\ limit} = \frac{Z_{sec}}{130\%}$$

$$Z_{sec\ limit} = \frac{59.95 \angle 31.8^\circ \Omega}{1.30}$$

$$Z_{sec\ limit} = 46.12 \angle 31.8^\circ \Omega$$

$$\theta_{transient\ load\ angle} = 31.8^\circ$$

Example Calculations: Option 4

Assume a Mho distance impedance relay with a maximum torque angle (MTA) set at 85°, then the maximum allowable impedance reach is:

$$\begin{aligned}\text{Eq. (63)} \quad Z_{max} &< \frac{|Z_{sec\ limit}|}{\cos(\theta_{MTA} - \theta_{transient\ load\ angle})} \\ Z_{max} &< \frac{46.12\ \Omega}{\cos(85.0^\circ - 31.8^\circ)} \\ Z_{max} &< \frac{46.12\ \Omega}{0.599} \\ Z_{max} &< 77.0 \angle 85.0^\circ\ \Omega\end{aligned}$$

Example Calculations: Option 5

This represents the calculation for three asynchronous generators applying a phase ~~time~~ overcurrent (e.g., 50, 51, or 51V-R) ~~voltage-restrained~~ relay. In this application it was assumed 20 Mvar of total static compensation was added.

Real Power output (P):

$$\begin{aligned}\text{Eq. (64)} \quad P &= 3 \times GEN_{Asynch_nameplate} \times pf \\ P &= 3 \times 40\ MVA \times 0.85 \\ P &= 102.0\ MW\end{aligned}$$

Reactive Power output (Q):

$$\begin{aligned}\text{Eq. (65)} \quad Q &= MVAR_{static} \\ &\quad + MVAR_{gen_static} \\ &\quad + (3 \times GEN_{Asynch_nameplate} \times \sin(\cos^{-1}(pf))) \\ Q &= 15\ Mvar + 5\ Mvar + (3 \times 40\ MVA \times \sin(\cos^{-1}(0.85))) \\ Q &= 83.2\ Mvar\end{aligned}$$

Option 5, Table 1 – Bus Voltage, calls for a 1.0 per unit of the high-side nominal voltage for the generator bus voltage (V_{gen}):

$$\text{Eq. (66)} \quad V_{gen} = 1.0\ p.\ u. \times V_{nom} \times GSU_{ratio}$$

Example Calculations: Option 5a

$$V_{gen} = 1.0 \times 345 \text{ kV} \times \left(\frac{22 \text{ kV}}{346.5 \text{ kV}} \right)$$

$$V_{gen} = 21.9 \text{ kV}$$

Apparent power (S):

$$\text{Eq. (67)} \quad S = P + jQ$$

$$S = 102.0 \text{ MW} + j83.2 \text{ Mvar}$$

$$S = 131.6 \angle 39.2^\circ \text{ MVA}$$

Primary current (I_{pri}):

$$\text{Eq. (68)} \quad I_{pri} = \frac{S^*}{\sqrt{3} \times V_{gen}}$$

$$I_{pri} = \frac{131.6 \angle -39.2^\circ \text{ MVA}}{1.73 \times 21.9 \text{ kV}}$$

$$I_{pri} = 3473 \angle -39.2^\circ \text{ A}$$

Secondary current (I_{sec}):

$$\text{Eq. (69)} \quad I_{sec} = \frac{I_{pri}}{CT_{Asynch_ratio}}$$

$$I_{sec} = \frac{3473 \angle -39.2^\circ \text{ A}}{\frac{5000}{5}}$$

$$I_{sec} = 3.473 \angle -39.2^\circ \text{ A}$$

To satisfy the 130% margin in Option 5a:

$$\text{Eq. (70)} \quad I_{sec \text{ limit}} > I_{sec} \times 130\%$$

$$I_{sec \text{ limit}} > 3.473 \angle -39.2^\circ \text{ A} \times 1.30$$

$$I_{sec \text{ limit}} > 4.52 \angle -39.2^\circ \text{ A}$$

Example Calculations: Option 5b

Similarly to Option 5a, this example represents the calculation for three asynchronous generators applying a phase overcurrent (e.g., 50, 51, or 51V-R) relay. In this application it was assumed that 20 Mvar of total static compensation was added.

Real Power output (P):

$$\begin{aligned}\text{Eq. (71)} \quad P &= 3 \times GEN_{Asynch_nameplate} \times pf \\ P &= 3 \times 40 \text{ MVA} \times 0.85 \\ P &= 102.0 \text{ MW}\end{aligned}$$

Reactive Power output (Q):

$$\begin{aligned}\text{Eq. (72)} \quad Q &= MVAR_{static} \\ &+ MVAR_{gen_static} \\ &+ (3 \times GEN_{Asynch_nameplate} \times \sin(\cos^{-1}(pf))) \\ Q &= 15 \text{ Mvar} + 5 \text{ Mvar} + (3 \times 40 \text{ MVA} \times \sin(\cos^{-1}(0.85))) \\ Q &= 83.2 \text{ Mvar}\end{aligned}$$

Option 5b, Table 1 – Bus Voltage, calls for a 1.0 per unit of the high-side nominal voltage for the generator bus voltage (V_{gen}):

$$\begin{aligned}\text{Eq. (73)} \quad V_{gen} &= 1.0 \text{ p.u.} \times V_{nom} \times GSR_{ratio} \\ V_{gen} &= 1.0 \times 345 \text{ kV} \times \left(\frac{22 \text{ kV}}{346.5 \text{ kV}} \right) \\ V_{gen} &= 21.9 \text{ kV}\end{aligned}$$

Apparent power (S):

$$\begin{aligned}\text{Eq. (74)} \quad S &= P + jQ \\ S &= 102.0 \text{ MW} + j83.2 \text{ Mvar} \\ S &= 131.6 \angle 39.2^\circ \text{ MVA}\end{aligned}$$

Primary current (I_{pri}):

$$\text{Eq. (75)} \quad I_{pri} = \frac{S^*}{\sqrt{3} \times V_{gen}}$$

Example Calculations: Option 5b

$$I_{pri} = \frac{131.6 \angle -39.2^\circ \text{ MVA}}{1.73 \times 21.9 \text{ kV}}$$

$$I_{pri} = 3473 \angle -39.2^\circ \text{ A}$$

Secondary current (I_{sec}):

Eq. (76)
$$I_{sec} = \frac{I_{pri}}{CT_{Asynch_ratio}}$$

$$I_{sec} = \frac{3473 \angle -39.2^\circ \text{ A}}{\frac{5000}{5}}$$

$$I_{sec} = 3.473 \angle -39.2^\circ \text{ A}$$

To satisfy Option 5b, the lower tolerance of the overcurrent element tripping characteristic shall not infringe upon the resource capability (including the Mvar output of the resource and any static or dynamic reactive power devices) See Figure A for more details.

Example Calculations: Options 7a and 10

~~This~~ These examples represent the calculation for a mixture of asynchronous (i.e., Option 10) and synchronous (i.e., Option 7a) generation (including inverter-based installations) applying a phase distance relay (e.g., 21) – directional toward the Transmission system. In this application it was assumed 20 Mvar of total static compensation was added.

Synchronous Generation (Option 7a)

Real Power output (P_{sync}):

Real Power output (P_{sync}):

Eq. (77)
$$P_{Synch} = GEN_{Synch_nameplate} \times pf$$

$$P_{Synch} = 903 \text{ MVA} \times 0.85$$

$$P_{Synch} = 767.6 \text{ MW}$$

Example Calculations: Options 7a and 10

Reactive Power output (Q_{Synch}):

$$\text{Eq. } Q_{Synch} = 150\% \times P_{Synch} \\ (7278)$$

$$Q_{Synch} = 1.50 \times 767.6 \text{ MW}$$

$$Q_{Synch} = 1151.3 \text{ MW}$$

Apparent power (S_{Synch}):

$$\text{Eq. } S_{Synch} = P_{Synch_reported} + jQ_{Synch} \\ (7379)$$

$$S_{Synch} = 700.0 \text{ MW} + j1151.3 \text{ Mvar}$$

Asynchronous Generation (Option 10)

Real Power output (P_{Asynch}):

Real Power output (P_{Asynch}):

$$\text{Eq. } P_{Asynch} = 3 \times GEN_{Asynch_nameplate} \times pf \\ (7480)$$

$$P_{Asynch} = 3 \times 40 \text{ MVA} \times 0.85$$

$$P_{Asynch} = 102.0 \text{ MW}$$

Reactive Power output (Q_{Asynch}):

$$\text{Eq. } Q_{Asynch} = MVAR_{static} + MVAR_{gen_static} \\ (7581) \quad + (3 \times GEN_{Asynch_nameplate} \times \sin(\cos^{-1}(pf)))$$

$$Q_{Asynch} = 15 \text{ Mvar} + 5 \text{ Mvar} + (3 \times 40 \text{ MVA} \times \sin(\cos^{-1}(0.85)))$$

$$Q_{Asynch} = 83.2 \text{ Mvar}$$

Apparent power (S_{Asynch}):

$$\text{Eq. } S_{Asynch} = P_{Asynch} + jQ_{Asynch} \\ (7682)$$

$$S_{Asynch} = 102.0 \text{ MW} + j83.2 \text{ Mvar}$$

Example Calculations: Options 7a and 10

Options 7a and 10, Table 1 – Bus Voltage, Option 7a specifies 0.95 per unit of the high-side nominal voltage for the generator bus voltage and Option 10 specifies 1.0 per unit of the high-side nominal voltage for generator bus voltage. Due to the presence of the synchronous generator, the 0.95 per unit bus voltage will be used as (V_{gen}) as it results in the most conservative voltage:

$$\text{Eq. (7783)} \quad V_{gen} = 0.95 \text{ p.u.} \times V_{nom} \times GSU_{ratio}$$

$$V_{gen} = 0.95 \times 345 \text{ kV} \times \left(\frac{22 \text{ kV}}{346.5 \text{ kV}} \right)$$

$$V_{gen} = 20.81 \text{ kV}$$

Apparent power (S) accounted for 115% margin requirement for a synchronous generator and 130% margin requirement for an asynchronous generator:

$$\text{Eq. (7884)} \quad S = 115\% \times (P_{Synch_reported} + jQ_{Synch}) + 130\% \times (P_{Asynch} + jQ_{Asynch})$$

$$S = 1.15 \times (700.0 \text{ MW} + j1151.3 \text{ Mvar}) + 1.30 \times (102.0 \text{ MW} + j83.2 \text{ Mvar})$$

$$S = 1711.8 \angle 56.8^\circ \text{ MVA}$$

Primary impedance (Z_{pri}):

$$\text{Eq. (7985)} \quad Z_{pri} = \frac{V_{gen}^2}{S^*}$$

$$Z_{pri} = \frac{(20.81 \text{ kV})^2}{1711.8 \angle -56.8^\circ \text{ MVA}}$$

$$Z_{pri} = 0.2527 \angle 56.8^\circ \Omega$$

Secondary impedance (Z_{sec}):

$$\text{Eq. (8086)} \quad Z_{sec} = Z_{pri} \times \frac{CT_{ratio}}{PT_{ratio}}$$

$$Z_{sec} = 0.2527 \angle 56.8^\circ \Omega \times \frac{25000}{\frac{5}{200}}$$

$$Z_{sec} = 0.2527 \angle 56.8^\circ \Omega \times 25$$

Example Calculations: Options 7a and 10

$$Z_{sec} = 6.32 \angle 56.8^\circ \Omega$$

No additional margin is needed; ~~therefore, the margin is 100%~~ because the synchronous apparent power has been multiplied by 1.15 (115%) and the asynchronous apparent power has been multiplied by 1.30 (130%) in Equation ~~85-84~~ to satisfy the margin requirements in Options 7a and 10:

$$\text{Eq. } \begin{matrix} (8187) \\ \end{matrix} Z_{sec\ limit} = \frac{Z_{sec}}{100\%}$$

$$Z_{sec\ limit} = \frac{6.32 \angle 56.8^\circ \Omega}{1.00}$$

$$Z_{sec\ limit} = 6.32 \angle 56.8^\circ \Omega$$

$$\theta_{transient\ load\ angle} = 56.8^\circ$$

Assume a Mho distance impedance relay with a maximum torque angle (MTA) set at 85° , then the maximum allowable impedance reach is:

$$\text{Eq. } \begin{matrix} (8288) \\ \end{matrix} Z_{max} < \frac{|Z_{sec\ limit}|}{\cos(\theta_{MTA} - \theta_{transient\ load\ angle})}$$

$$Z_{max} < \frac{6.32 \Omega}{\cos(85.0^\circ - 56.8^\circ)}$$

$$Z_{max} < \frac{6.32 \Omega}{0.881}$$

$$Z_{max} < 7.17 \angle 85.0^\circ \Omega$$

Example Calculations: Options 8a and 9a

Options 8a and 9a represents the simplest calculation for synchronous generators applying a phase time overcurrent (e.g., 50, 51, or 67) relay. The following uses the $GEN_{synchron_nameplate}$ value to represent an "aggregate" value to illustrate the option:

Real Power output (P):

$$\text{Eq. } \begin{matrix} (8389) \\ \end{matrix} P = GEN_{synchron_nameplate} \times pf$$

Example Calculations: Options 8a and 9a

$$P = 903 \text{ MVA} \times 0.85$$

$$P = 767.6 \text{ MW}$$

Reactive Power output (Q):

$$\text{Eq. } Q = 150\% \times P$$

(8490)

$$Q = 1.50 \times 767.6 \text{ MW}$$

$$Q = 1151.3 \text{ Mvar}$$

Options 8a and 9a, Table 1 – Bus Voltage, calls for a generator bus voltage corresponding to 0.95 per unit of the high-side nominal voltage times the turns ratio of the generator step-up transformer generator bus voltage (V_{gen}):

$$\text{Eq. } V_{gen} = 0.95 \text{ p.u.} \times V_{nom} \times GSU_{ratio}$$

(8591)

$$V_{gen} = 0.95 \times 345 \text{ kV} \times \left(\frac{22 \text{ kV}}{346.5 \text{ kV}} \right)$$

$$V_{gen} = 20.81 \text{ kV}$$

Apparent power (S):

$$\text{Eq. } S = P_{Synch_reported} + jQ$$

(8692)

$$S = 700.0 \text{ MW} + j1151.3 \text{ Mvar}$$

$$S = 1347.4 \angle 58.7^\circ \text{ MVA}$$

Primary current (I_{pri}):

$$\text{Eq. } I_{pri} = \frac{S}{\sqrt{3} \times V_{gen}}$$

(8793)

$$I_{pri} = \frac{1347.4 \text{ MVA}}{1.73 \times 20.81 \text{ kV}}$$

$$I_{pri} = 37383 \text{ A}$$

Example Calculations: Options 8a and 9a

Secondary current (I_{sec}):

$$\begin{aligned} \text{Eq. } (8894) \quad I_{sec} &= \frac{I_{pri}}{CT_{ratio}} \\ I_{sec} &= \frac{37383 \text{ A}}{\frac{25000}{5}} \\ I_{sec} &= 7.477 \text{ A} \end{aligned}$$

To satisfy the 115% margin in Options 8a and 9a:

$$\begin{aligned} \text{Eq. } (8995) \quad I_{sec \text{ limit}} &> I_{sec} \times 115\% \\ I_{sec \text{ limit}} &> 7.477 \text{ A} \times 1.15 \\ I_{sec \text{ limit}} &> 8.598 \text{ A} \end{aligned}$$

Example Calculations: Options 8b and 9b

Options 8b and 9b represents a more complex-precise calculation for synchronous generators applying a phase time overcurrent (e.g., 50, 51, or 67) relay. The following uses the $GEN_{Synch_nameplate}$ value to represent an “aggregate” value to illustrate the option:

Real Power output (P):

$$\begin{aligned} \text{Eq. } (9096) \quad P &= GEN_{Synch_nameplate} \times pf \\ P &= 903 \text{ MVA} \times 0.85 \\ P &= 767.6 \text{ MW} \end{aligned}$$

Reactive Power output (Q):

$$\begin{aligned} \text{Eq. } (9197) \quad Q &= 150\% \times P \\ Q &= 1.50 \times 767.6 \text{ MW} \\ Q &= 1151.3 \text{ Mvar} \end{aligned}$$

Example Calculations: Options 8b and 9b

Convert Real Power, Reactive Power, and transformer reactance to per unit values on 767.6 MVA base (GSU transformer MVA_{base}).

Real Power output (P):

$$\text{Eq. (9298)} \quad P_{pu} = \frac{P_{Synch_reported}}{MVA_{base}}$$

$$P_{pu} = \frac{700.0 \text{ MW}}{767.6 \text{ MVA}}$$

$$P_{pu} = 0.91 \text{ p.u.}$$

Reactive Power output (Q):

$$\text{Eq. (9399)} \quad Q_{pu} = \frac{Q}{MVA_{base}}$$

$$Q_{pu} = \frac{1151.3 \text{ Mvar}}{767.6 \text{ MVA}}$$

$$Q_{pu} = 1.5 \text{ p.u.}$$

Transformer impedance:

$$\text{Eq. (94100)} \quad X_{pu} = X_{GSU(oid)} \times \frac{MVA_{base}}{MVA_{GSU}}$$

$$X_{pu} = 12.14\% \times \left(\frac{767.6 \text{ MVA}}{903 \text{ MVA}} \right)$$

$$X_{pu} = 0.1032 \text{ p.u.}$$

Using the formula below; calculate the low-side GSU transformer voltage ($V_{low-side}$) using 0.85 p.u. high-side voltage ($V_{high-side}$). Estimate Assume initial low-side voltage to be 0.95 p.u. and repeat the calculation as necessary until $V_{low-side}$ converges. A convergence of less than one percent (<1%) between iterations is considered sufficient:

$$\text{Eq. (95101)} \quad \theta_{low-side} = \sin^{-1} \left[\frac{(P_{pu} \times |X_{pu}|)}{(|V_{low-side}| \times |V_{high-side}|)} \right]$$

$$\theta_{low-side} = \sin^{-1} \left[\frac{(0.91 \times 0.1032)}{(0.95 \times 0.85)} \right]$$

Example Calculations: Options 8b and 9b

$$\text{Eq. (96102)} \quad |V_{low-side}| = \frac{|V_{high-side}| \times \cos(\theta_{low-side}) \pm \sqrt{|V_{high-side}|^2 \times \cos^2(\theta_{low-side}) + 4 \times Q_{pu} \times X_i}}{2}$$

$$|V_{low-side}| = \frac{|0.85| \times \cos(6.7^\circ) \pm \sqrt{|0.85|^2 \times \cos^2(6.7^\circ) + 4 \times 1.5 \times 0.1032}}{2}$$

$$|V_{low-side}| = \frac{|0.85| \times 0.9931 \pm \sqrt{0.7225 \times 0.9864 + 0.6192}}{2}$$

$$|V_{low-side}| = \frac{0.8441 \pm 1.1541}{2}$$

$$|V_{low-side}| = 0.9991 \text{ p.u.}$$

Use the new estimated $V_{low-side}$ value of 0.9991 per unit for the second iteration:

$$\text{Eq. (97103)} \quad \theta_{low-side} = \sin^{-1} \left[\frac{(P_{pu} \times |X_{pu}|)}{(|V_{low-side}| \times |V_{high-side}|)} \right]$$

$$\theta_{low-side} = \sin^{-1} \left[\frac{(0.91 \times 0.1032)}{(0.9991 \times 0.85)} \right]$$

$$\theta_{low-side} = 6.3^\circ$$

$$\text{Eq. (98104)} \quad |V_{low-side}| = \frac{|V_{high-side}| \times \cos(\theta_{low-side}) \pm \sqrt{|V_{high-side}|^2 \times \cos^2(\theta_{low-side}) + 4 \times Q_{pu} \times X_i}}{2}$$

$$|V_{low-side}| = \frac{|0.85| \times \cos(6.3^\circ) \pm \sqrt{|0.85|^2 \times \cos^2(6.3^\circ) + 4 \times 1.5 \times 0.1032}}{2}$$

$$|V_{low-side}| = \frac{|0.85| \times 0.9940 \pm \sqrt{0.7225 \times 0.9880 + 0.6192}}{2}$$

$$|V_{low-side}| = \frac{0.8449 \pm 1.1546}{2}$$

$$|V_{low-side}| = 0.9998 \text{ p.u.}$$

Example Calculations: Options 8b and 9b

To account for system high-side nominal voltage and the transformer tap ratio:

$$\text{Eq. } V_{bus} = |V_{low-side}| \times V_{nom} \times GSU_{ratio}$$

(99105)

$$V_{bus} = 0.9998 \text{ p. u.} \times 345 \text{ kV} \times \left(\frac{22 \text{ kV}}{346.5 \text{ kV}} \right)$$

$$V_{bus} = 21.90 \text{ kV}$$

Apparent power (S):

$$\text{Eq. } S = P_{Synch_reported} + jQ$$

(100106)

$$S = 700.0 \text{ MW} + j1151.3 \text{ Mvar}$$

$$S = 1347.4 \angle 58.7^\circ \text{ MVA}$$

Primary current (I_{pri}):

$$\text{Eq. } I_{pri} = \frac{S}{\sqrt{3} \times V_{bus}}$$

(101107)

$$I_{pri} = \frac{1347.4 \text{ MVA}}{1.73 \times 21.90 \text{ kV}}$$

$$I_{pri} = 35553 \text{ A}$$

Secondary current (I_{sec}):

$$\text{Eq. } I_{sec} = \frac{I_{pri}}{CT_{ratio}}$$

(102108)

$$I_{sec} = \frac{35553 \text{ A}}{\frac{25000}{5}}$$

$$I_{sec} = 7.111 \text{ A}$$

Example Calculations: Options 8b and 9b

To satisfy the 115% margin in Options 8b and 9b:

$$\text{Eq. } I_{sec\ limit} > I_{sec} \times 115\%$$

(403109)

$$I_{sec\ limit} > 7.111\ A \times 1.15$$

$$I_{sec\ limit} > 8.178\ A$$

Example Calculations: Options 8a, 9a, 11, and 12

This [example](#) represents the calculation for a mixture of asynchronous and synchronous generators applying a phase ~~time~~-overcurrent (e.g., 50, 51, or 67) relays. In this application it was assumed 20 Mvar of total static compensation was added. The current transformers (CT) are located on the low-side of the GSU transformer.

Synchronous Generation (Options 8a and 9a)

~~Real Power output (P_{Synch}):~~

Real Power output (P_{Synch}):

$$\text{Eq. } P_{Synch} = GEN_{Synch_nameplate} \times pf$$

(404110)

$$P_{Synch} = 903\ MVA \times .85$$

$$P_{Synch} = 767.6\ MW$$

Reactive Power output (Q_{Synch}):

$$\text{Eq. } Q_{Synch} = 150\% \times P_{Synch}$$

(405111)

$$Q_{Synch} = 1.50 \times 767.6\ MW$$

$$Q_{Synch} = 1151.3\ Mvar$$

Example Calculations: Options 8a, 9a, 11, and 12

Apparent power (S_{Synch}):

$$\text{Eq. } S_{Synch} = P_{Synch_reported} + jQ_{Synch} \quad (406112)$$

$$S_{Synch} = 700.0 \text{ MW} + j1151.3 \text{ Mvar}$$

$$S_{Synch} = 1347.4 \angle 58.7^\circ \text{ MVA}$$

Option 8a, Table 1 – Bus Voltage calls for a 0.95 per unit of the high-side nominal voltage as a basis for generator bus voltage (V_{gen}):

$$\text{Eq. } V_{gen} = 0.95 \text{ p. u.} \times V_{nom} \times GSU_{ratio} \quad (407113)$$

$$V_{gen} = 0.95 \times 345 \text{ kV} \times \left(\frac{22 \text{ kV}}{346.5 \text{ kV}} \right)$$

$$V_{gen} = 20.81 \text{ kV}$$

Primary current ($I_{pri-sync}$):

$$\text{Eq. } I_{pri-sync} = \frac{115\% \times S_{Synch}^*}{\sqrt{3} \times V_{gen}} \quad (408114)$$

$$I_{pri-sync} = \frac{1.15 \times (1347.4 \angle -58.7^\circ \text{ MVA})}{1.73 \times 20.81 \text{ kV}}$$

$$I_{pri-sync} = 43061 \angle -58.7^\circ \text{ A}$$

Asynchronous Generation (Options 11 and 12)

Real Power output (P_{Asynch}):

Real Power output (P_{Asynch}):

$$\text{Eq. } P_{Asynch} = 3 \times GEN_{Asynch_nameplate} \times pf \quad (409115)$$

$$P_{Asynch} = 3 \times 40 \text{ MVA} \times 0.85$$

$$P_{Asynch} = 102.0 \text{ MW}$$

Example Calculations: Options 8a, 9a, 11, and 12

Reactive Power output (Q_{Asynch}):

$$\text{Eq. } Q_{Asynch} = MVAR_{static} + MVAR_{gen_static} + GEN_{Asynch_nameplate} \times \sin(\cos^{-1}(pf))$$

$$Q_{Asynch} = 15 \text{ Mvar} + 5 \text{ Mvar} + (3 \times 40 \text{ MVA} \times \sin(\cos^{-1}(0.85)))$$

$$Q_{Asynch} = 83.2 \text{ Mvar}$$

Option 11, Table 1 – Bus Voltage, calls for a 1.0 per unit of the high-side nominal voltage for the generator bus voltage (V_{gen}), however due to the presence of synchronous generator 0.95 per unit bus voltage will be used:

$$\text{Eq. } V_{gen} = 0.95 \text{ p. u.} \times V_{nom} \times GSU_{ratio}$$

$$V_{gen} = 0.95 \times 345 \text{ kV} \times \left(\frac{22 \text{ kV}}{346.5 \text{ kV}} \right)$$

$$V_{gen} = 20.81 \text{ kV}$$

Apparent power (S_{Asynch}):

$$\text{Eq. } S_{Asynch} = 130\% \times (P_{Asynch} + jQ_{Asynch})$$

$$S_{Asynch} = 1.30 \times (102.0 \text{ MW} + j83.2 \text{ Mvar})$$

$$S_{Asynch} = 171.1 \angle 39.2^\circ \text{ MVA}$$

Primary current ($I_{pri-async}$):

$$\text{Eq. } I_{pri-async} = \frac{S_{Asynch}}{\sqrt{3} \times V_{gen}}$$

$$I_{pri-async} = \frac{171.1 \angle -39.2^\circ \text{ MVA}}{1.73 \times 20.81 \text{ kV}}$$

$$I_{pri-async} = 4755 \angle -39.2^\circ \text{ A}$$

Secondary current (I_{sec}):

$$\text{Eq. } I_{sec} = \frac{I_{pri-async}}{CT_{ratio}} + \frac{I_{pri-async}}{CT_{ratio}}$$

Example Calculations: Options 8a, 9a, 11, and 12

$$I_{sec} = \frac{43061 \angle -58.7^\circ A}{\frac{25000}{5}} + \frac{4755 \angle -39.2^\circ A}{\frac{25000}{5}}$$

$$I_{sec} = 9.514 \angle -56.8^\circ A$$

No additional margin is needed; ~~therefore, the margin is 100%~~ because the synchronous apparent power has been multiplied by 1.15 (115%) in Equation [94-114](#) and the asynchronous apparent power has been multiplied by 1.30 (130%) in Equation [98-118](#):

Eq. $I_{sec\ limit} > I_{sec} \times 100\%$
(~~415121~~)

$$I_{sec\ limit} > 9.514 \angle -56.8^\circ A \times 1.00$$

$$I_{sec\ limit} > 9.514 \angle -56.8^\circ A$$

Example Calculations: Options 8c and 9c

This example uses Option 15b as a simulation example for a synchronous generator applying a phase ~~time~~ overcurrent relay. ~~(e.g., 50, 51, or 67)~~. In this application the same synchronous generator is modeled as for Options 1c, 2c, and 7c. The CTs are located on the low-side of the GSU transformer.

The generator Reactive Power and generator bus voltage are determined by simulation. The maximum Reactive Power output on the low-side of the GSU transformer, P_r during field-forcing, P_r is used ~~assince~~ this value will correspond to the highest current. The corresponding generator bus voltage is also used in the calculation. Note that although the excitation limiter reduces the field, the duration of the Reactive Power output achieved for this condition is sufficient to operate a phase overcurrent relay.

Formatted Table

Example Calculations: Options 8c and 9c

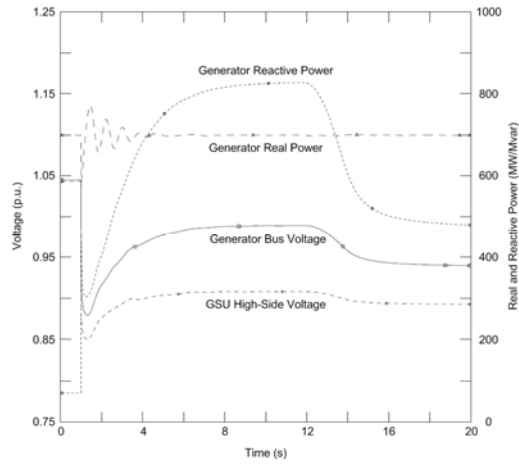

In this simulation the following values are derived:

$$Q = 827.4 \text{ Mvar}$$

$$V_{bus_simulated} = 0.989 \times V_{gen} = 21.76 \text{ kV}$$

The other value required is the Real Power output which is modeled in the simulation at 100% of the gross MW capability reported to the Transmission Planner. In this case:

$$P_{reported} = 700.0 \text{ MW}$$

Formatted Table

Formatted Table

Example Calculations: Options 8c and 9c

Formatted Table

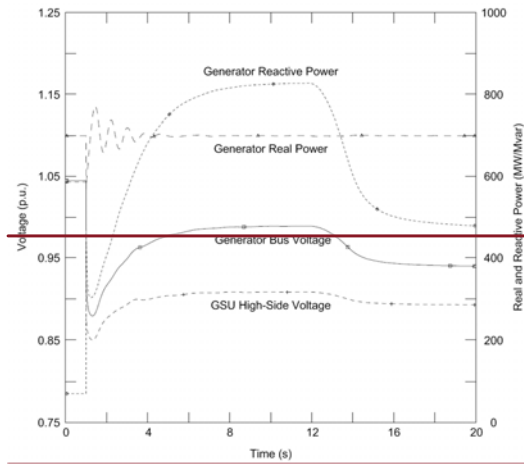

Apparent power (S):

$$\text{Eq. } S = P_{\text{Synch_reported}} + jQ$$

(116,122)

$$S = 700.0 \text{ MW} + j827.4 \text{ Mvar}$$

$$S = 1083.8 \angle 49.8^\circ$$

Primary current (I_{pri}):

$$\text{Eq. } I_{pri} = \frac{S}{\sqrt{3} \times V_{bus_simulated}}$$

(117,123)

$$I_{pri} = \frac{1083.8 \text{ MVA}}{1.73 \times 21.76 \text{ kV}}$$

$$I_{pri} = 28790 \text{ A}$$

Secondary current (I_{sec}):

$$\text{Eq. } I_{sec} = \frac{I_{pri}}{CT_{ratio}}$$

(118,124)

$$I_{sec} = \frac{28790 \text{ A}}{5}$$

Example Calculations: Options 8c and 9c

$$I_{sec} = 5.758 A$$

To satisfy the 115% margin in Options 8c and 9c:

$$\text{Eq. } I_{sec \text{ limit}} > I_{sec} \times 115\% \quad (119125)$$

$$I_{sec \text{ limit}} > 5.758 A \times 1.15$$

$$I_{sec \text{ limit}} > 6.622 A$$

Example Calculations: Option10

This [examples](#) represents the calculation for three asynchronous generators (including inverter-based installations) applying a phase distance relay ([e.g., 21](#)) – directional toward the Transmission system. In this application it was assumed 20 Mvar of total static compensation was added.

Real Power output (P):

$$\text{Eq. } P = 3 \times GEN_{Asynch_nameplate} \times pf \quad (120126)$$

$$P = 3 \times 40 MVA \times 0.85$$

$$P = 102.0 MW$$

Reactive Power output (Q):

$$\text{Eq. } Q = MVAR_{static} + MVAR_{gen_static} + (3 \times GEN_{Asynch_nameplate} \times \sin(\cos^{-1}(pf))) \quad (121127)$$

$$Q = 15 Mvar + 5 Mvar + (3 \times 40 MVA \times \sin(\cos^{-1}(0.85)))$$

$$Q = 83.2 Mvar$$

Option 10, Table 1 – Bus Voltage, calls for a 1.0 per unit of the high-side nominal voltage for the generator bus voltage (V_{gen}):

$$\text{Eq. } V_{gen} = 1.0 p.u. \times V_{nom} \times GSU_{ratio} \quad (122128)$$

Formatted Table

Example Calculations: Option10

$$V_{gen} = 1.0 \times 345 \text{ kV} \times \left(\frac{22 \text{ kV}}{346.5 \text{ kV}} \right)$$

$$V_{gen} = 21.9 \text{ kV}$$

Apparent power (S):

Eq. $S = P + jQ$
(+23,129)

$$S = 102.0 \text{ MW} + j83.2 \text{ Mvar}$$

$$S = 131.6 \angle 39.2^\circ \text{ MVA}$$

Primary impedance (Z_{pri}):

Eq. $Z_{pri} = \frac{V_{gen}^2}{S^*}$
(+24,130)

$$Z_{pri} = \frac{(21.9 \text{ kV})^2}{131.6 \angle -39.2^\circ \text{ MVA}}$$

$$Z_{pri} = 3.644 \angle 39.2^\circ \Omega$$

Secondary impedance (Z_{sec}):

Eq. $Z_{sec} = Z_{pri} \times \frac{CT_{Asynch_ratio}}{PT_{ratio}}$
(+25,131)

$$Z_{sec} = 3.644 \angle 39.2^\circ \Omega \times \frac{5000}{\frac{5}{200}} \frac{1}{1}$$

$$Z_{sec} = 3.644 \angle 39.2^\circ \Omega \times 5$$

$$Z_{sec} = 18.22 \angle 39.2^\circ \Omega$$

To satisfy the 130% margin in Option 10:

Eq. $Z_{seclimit} = \frac{Z_{sec}}{130\%}$
(+26,132)

$$Z_{seclimit} = \frac{18.22 \angle 39.2^\circ \Omega}{1.30}$$

$$Z_{seclimit} = 14.02 \angle 39.2^\circ \Omega$$

Example Calculations: Option10

$$\theta_{transient\ load\ angle} = 39.2^\circ$$

Assume a Mho distance impedance relay with a maximum torque angle (MTA) set at 85° , then the maximum allowable impedance reach is:

$$\text{Eq. (427133)} \quad Z_{max} < \frac{|Z_{sec\ limit}|}{\cos(\theta_{MTA} - \theta_{transient\ load\ angle})}$$

$$Z_{max} < \frac{14.02\ \Omega}{\cos(85.0^\circ - 39.2^\circ)}$$

$$Z_{max} < \frac{14.02\ \Omega}{0.6972}$$

$$Z_{max} < 20.11 \angle 85.0^\circ\ \Omega$$

Example Calculations: Options 11 and 12

Option 11 represents the calculation for a GSU transformer applying a phase ~~time~~ overcurrent (e.g., 50 or 51) relay connected to three asynchronous generators. Similarly, these calculations can be applied to Option 12 for a phase directional ~~time~~-overcurrent relay (e.g., 67) directional toward the Transmission system. In this application it was assumed 20 Mvar of total static compensation was added.

Real Power output (P):

$$\text{Eq. (428134)} \quad P = 3 \times GEN_{Asynch_nameplate} \times pf$$

$$P = 3 \times 40\ MVA \times 0.85$$

$$P = 102.0\ MW$$

Reactive Power output (Q):

$$\text{Eq. (429135)} \quad Q = MVAR_{static} + MVAR_{gen_static} + (3 \times GEN_{Asynch_nameplate} \times \sin(\cos^{-1}(pf)))$$

$$Q = 15\ Mvar + 5\ Mvar + (3 \times 40\ MVA \times \sin(\cos^{-1}(0.85)))$$

$$Q = 83.2\ Mvar$$

Example Calculations: Options 11 and 12

Options 11 and 12, Table 1 – Bus Voltage, calls for a 1.0 per unit of the high-side nominal voltage for the generator bus voltage (V_{gen}):

$$\text{Eq. } V_{gen} = 1.0 \text{ p.u.} \times V_{nom} \times GSU_{ratio}$$

(130136)

$$V_{gen} = 1.0 \times 345 \text{ kV} \times \left(\frac{22 \text{ kV}}{346.5 \text{ kV}} \right)$$

$$V_{gen} = 21.9 \text{ kV}$$

Apparent power (S):

$$\text{Eq. } S = P + jQ$$

(131137)

$$S = 102.0 \text{ MW} + j83.2 \text{ Mvar}$$

$$S = 131.6 \angle 39.2^\circ \text{ MVA}$$

Primary current (I_{pri}):

$$\text{Eq. } I_{pri} = \frac{S^*}{\sqrt{3} \times V_{gen}}$$

(132138)

$$I_{pri} = \frac{131.6 \angle -39.2^\circ \text{ MVA}}{1.73 \times 21.9 \text{ kV}}$$

$$I_{pri} = 3473 \angle -39.2^\circ \text{ A}$$

Secondary current (I_{sec}):

$$\text{Eq. } I_{sec} = \frac{I_{pri}}{CT_{Asynch_ratio}}$$

(133139)

$$I_{sec} = \frac{3473 \angle -39.2^\circ \text{ A}}{\frac{5000}{5}}$$

$$I_{sec} = 3.473 \angle -39.2^\circ \text{ A}$$

To satisfy the 130% margin in Options 11 and 12:

$$\text{Eq. } I_{sec \text{ limit}} > I_{sec} \times 130\%$$

(134140)

Example Calculations: Options 11 and 12

$$I_{sec\ limit} > 3.473 \angle -39.2^\circ A \times 1.30$$

$$I_{sec\ limit} > 4.515 \angle -39.2^\circ A$$

Example Calculations: Options 13a and 13b

Option 13a for the UAT assumes ~~that~~ the maximum nameplate rating of the winding is utilized for the purposes of the calculations and the appropriate voltage. Similarly, Option 13b uses the measured current while operating at the maximum gross MW capability reported to the Transmission Planner.

Primary current (I_{pri}):

$$\text{Eq. (435141)} \quad I_{pri} = \frac{UAT_{nameplate}}{\sqrt{3} \times V_{UAT}}$$

$$I_{pri} = \frac{60\ MVA}{1.73 \times 13.8\ kV}$$

$$I_{pri} = 2510.2\ A$$

Secondary current (I_{sec}):

$$\text{Eq. (436142)} \quad I_{sec} = \frac{I_{pri}}{CT_{UAT}}$$

$$I_{sec} = \frac{2510.2\ A}{\frac{5000}{5}}$$

$$I_{sec} = 2.51\ A$$

To satisfy the 150% margin in Options 13a:

$$\text{Eq. (437143)} \quad I_{sec\ limit} > I_{sec} \times 150\%$$

$$I_{sec\ limit} > 2.51\ A \times 1.50$$

$$I_{sec\ limit} > 3.77\ A$$

Example Calculations: Option 14a

Option 14a represents the calculation for a synchronous generation relays installed on the high-side of the GSU transformer, including relays installed on the remote end of line, for Elements that connect a GSU transformer to the Transmission system that are used exclusively to export energy directly from a BES generating unit or generating plant that connected to synchronous generation. In this example, the Element is applying protected by a phase distance (e.g., 21) relay directional toward the Transmission system. The CTs are located on the high-side of the GSU transformer.

Real Power output (P):

$$\text{Eq. } P = GEN_{Synch_nameplate} \times pf$$

(+38144)

$$P = 903 \text{ MVA} \times 0.85$$

$$P = 767.6 \text{ MW}$$

Reactive Power output (Q):

$$\text{Eq. } Q = 120\% \times P$$

(+39145)

$$Q = 1.20 \times 767.6 \text{ MW}$$

$$Q = 921.1 \text{ Mvar}$$

Option 14a, Table 1 – Bus Voltage, calls for a 0.85 per unit of the high-sideline nominal voltage for the GSU transformer voltage (V_{nom}):

$$\text{Eq. } V_{bus} = 0.85 \text{ p. u.} \times V_{nom}$$

(+40146)

$$V_{gen} = 0.85 \times 345 \text{ kV}$$

$$V_{gen} = 293.25 \text{ kV}$$

Apparent power (S):

$$\text{Eq. } S = P_{Synch_reported} + jQ$$

(+41147)

$$S = 700.0 \text{ MW} + j921.1 \text{ Mvar}$$

$$S = 1157.0 \angle 52.77^\circ \text{ MVA}$$

Example Calculations: Option 14a

$$\theta_{transient\ load\ angle} = 52.77^\circ$$

Primary impedance (Z_{pri}):

$$\text{Eq. (442148)} \quad Z_{pri} = \frac{V_{bus}^2}{S^*}$$

$$Z_{pri} = \frac{(293.25\ kV)^2}{1157.0 \angle -52.77^\circ\ MVA}$$

$$Z_{pri} = 74.335 \angle 52.77^\circ\ \Omega$$

Secondary impedance (Z_{sec}):

$$\text{Eq. (443149)} \quad Z_{sec} = Z_{pri} \times \frac{CT_{ratio\ hv}}{PT_{ratio\ hv}}$$

$$Z_{sec} = 74.335 \angle 52.77^\circ\ \Omega \times \frac{\frac{2000}{5}}{\frac{2000}{1}}$$

$$Z_{sec} = 74.335 \angle 52.77^\circ\ \Omega \times 0.2$$

$$Z_{sec} = 14.867 \angle 52.77^\circ\ \Omega$$

To satisfy the 115% margin in Option 14a:

$$\text{Eq. (444150)} \quad Z_{sec\ limit} = \frac{Z_{sec}}{115\%}$$

$$Z_{sec\ limit} = \frac{14.867 \angle 52.77^\circ\ \Omega}{1.15}$$

$$Z_{sec\ limit} = 12.928 \angle 52.77^\circ\ \Omega$$

$$\theta_{transient\ load\ angle} = 52.77^\circ$$

Assume a Mho distance impedance relay with a maximum torque angle (MTA) set at 85° , then the maximum allowable impedance reach is:

$$\text{Eq. (445151)} \quad Z_{max} < \frac{|Z_{sec\ limit}|}{\cos(\theta_{MTA} - \theta_{transient\ load\ angle})}$$

$$Z_{max} < \frac{12.928\ \Omega}{\cos(85.0^\circ - 52.77^\circ)}$$

Example Calculations: Option 14a

$$Z_{max} < \frac{12.928 \Omega}{0.846}$$

$$Z_{max} < 15.283 \angle 85.0^\circ \Omega$$

Example Calculations: Option 14b

Option 14b represents the simulation for ~~a synchronous generation~~ relays installed on the ~~high-side of the GSU transformer, including relays installed on the remote end of line, for~~ Elements that connect a GSU transformer to the Transmission system that are used exclusively to export energy directly from a BES generating unit or generating plant ~~that connected to synchronous generation. In this example, the Element is applying~~ protected by a phase distance (e.g., 21) relay directional toward the Transmission system. The CTs are located on the high-side of the GSU transformer.

~~Relays installed on the high-side of the GSU transformer, including relays installed on the remote end of line, simulation is used to determine the simulated line voltage at the relay location coincident with the highest Reactive Power output achieved during field-forcing in response to a 0.85 per unit of the line nominal voltage at the remote end of the line prior to field-forcing. This is achieved by modeling a shunt at the remote end (i.e., at the Transmission system) of the line during simulation.~~

The ~~maximum~~ Reactive Power flow and ~~high-side bus voltage~~ coincident voltage for both the ~~high-side of the GSU transformer and remote end of the line~~ are determined by simulation. The maximum Reactive Power output on the high-side of the GSU transformer ~~and remote end of the line~~ during field-forcing is used as ~~this value~~ these values will correspond to the lowest apparent impedance, ~~at the relay location~~. The corresponding ~~high-side bus~~ simulated voltage is also used in the calculation. Note that although the excitation limiter reduces the field, the duration of the Reactive Power output achieved for this condition is sufficient to operate a phase distance relay.

Example Calculations: Option 14b

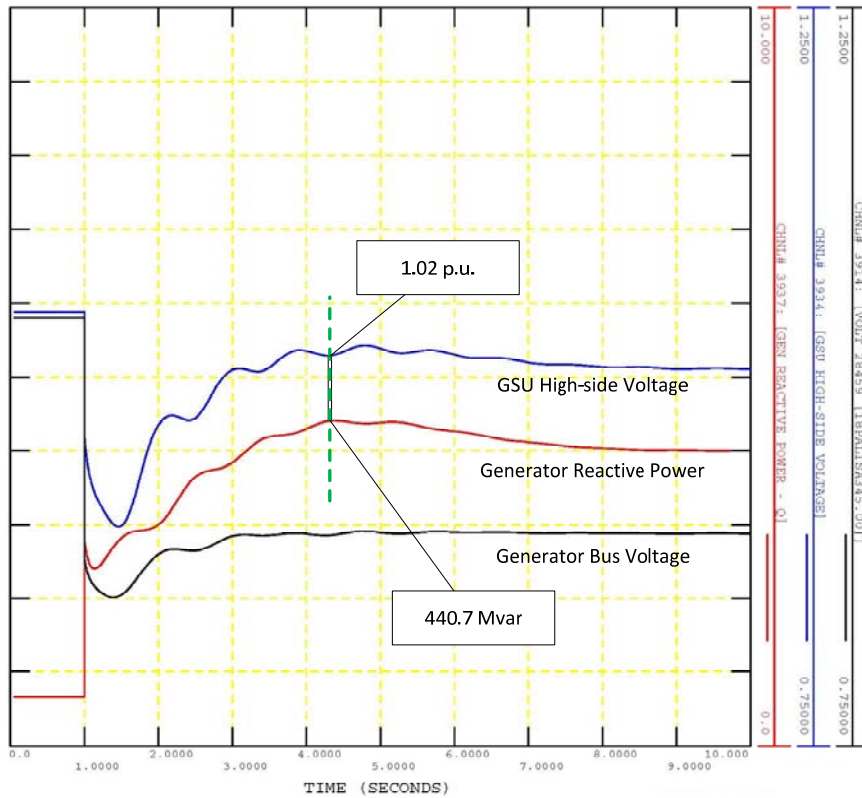

The Reactive Power flow and high-side bus voltage are determined by simulation. The maximum Reactive Power output on the high side of the GSU transformer during field-forcing is used as this value will correspond to the lowest apparent impedance. The corresponding high-side bus voltage is also used in the calculation. Note that although the excitation limiter reduces the field, the duration of the Reactive Power output achieved for this condition is sufficient to operate a phase distance relay.

In this simulation the following values are derived:

$$Q = 703.6 \text{ Mvar}$$

$$V_{bus} = 0.908 \times V_{nom} = 313.3 \text{ kV}$$

Formatted Table

Example Calculations: Option 14b

The other value required is the Real Power output which is modeled in the simulation at 100% of the gross MW capability reported to the Transmission Planner. In this case:

$$P_{reported} = 700.0 \text{ MW}$$

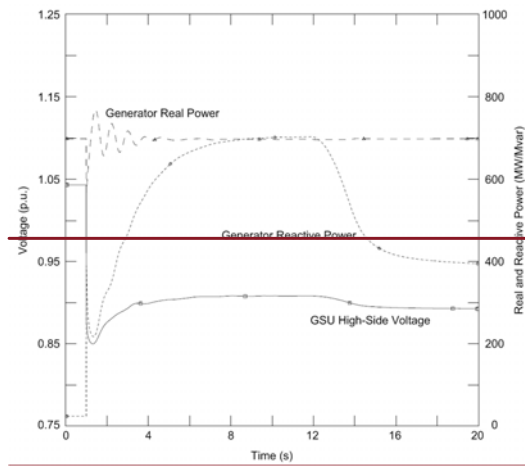

Apparent power (S):

$$\text{Eq. } S = P_{\text{synch_reported}} + jQ$$

(446152)

$$S = 700.0 \text{ MW} + j703.6 \text{ Mvar}$$

$$S = 992.5 \angle 45.1^\circ \text{ MVA}$$

$$\theta_{\text{transient load angle}} = 45.1^\circ$$

Primary impedance (Z_{pri}):

$$\text{Eq. } Z_{pri} = \frac{V_{bus}^2}{S^*}$$

(447153)

$$Z_{pri} = \frac{(313.3 \text{ kV})^2}{992.5 \angle -45.1^\circ \text{ MVA}}$$

$$Z_{pri} = 98.90 \angle 45.1^\circ \Omega$$

Example Calculations: Option 14b

Secondary impedance (Z_{sec}):

$$\begin{aligned} \text{Eq. (148154)} \quad Z_{sec} &= Z_{pri} \times \frac{CT_{ratio_{hv}}}{PT_{ratio_{hv}}} \\ Z_{sec} &= 98.90 \angle 45.1^\circ \Omega \times \frac{\frac{2000}{5}}{\frac{2000}{1}} \\ Z_{sec} &= 98.90 \angle 45.1^\circ \Omega \times 0.2 \\ Z_{sec} &= 19.78 \angle 45.1^\circ \Omega \end{aligned}$$

To satisfy the 115% margin in Option 14b:

$$\begin{aligned} \text{Eq. (149155)} \quad Z_{sec\ limit} &= \frac{Z_{sec}}{115\%} \\ Z_{sec\ limit} &= \frac{19.78 \angle 45.1^\circ \Omega}{1.15} \\ Z_{sec\ limit} &= 17.20 \angle 45.1^\circ \Omega \\ \theta_{transient\ load\ angle} &= 45.1^\circ \end{aligned}$$

Assume a Mho distance impedance relay with a maximum torque angle (MTA) set at 85° , then the maximum allowable impedance reach is:

$$\begin{aligned} \text{Eq. (150156)} \quad Z_{max} &< \frac{|Z_{sec\ limit}|}{\cos(\theta_{MTA} - \theta_{transient\ load\ angle})} \\ Z_{max} &< \frac{17.20 \Omega}{\cos(85.0^\circ - 45.1^\circ)} \\ Z_{max} &< \frac{17.20 \Omega}{0.767} \\ Z_{max} &< 22.42 \angle 85.0^\circ \Omega \end{aligned}$$

Example Calculations: Options 15a and 16a

Options 15a and 16a represent the calculation for ~~a synchronous generation relay installed on the high-side of the GSU transformer, including relays installed at the remote end of the line,~~ for Elements that connect a GSU transformer to the Transmission system that are used exclusively to export energy directly from a BES generating unit or generating plant- ~~connected to synchronous generation.~~

Option 15a represents applying a phase time overcurrent relay (e.g., 51) and/or ~~Phase~~ ~~instantaneous~~ overcurrent supervisory elements (e.g., 50) associated with current-based, communication-assisted schemes where the scheme is capable of tripping for loss of communications —installed on the high-side of the GSU transformer- ~~, including relays installed at the remote end of the line.~~

Option 16a represents applying a phase directional ~~time overcurrent relay or Phase~~ ~~directional~~ ~~instantaneous~~ overcurrent supervisory ~~elements (element (e.g., 67))~~ associated with current-based, communication-assisted schemes where the scheme is capable of tripping for loss of communications —directional toward the Transmission system— installed on the high-side of the GSU ~~and at the remote end of the line and/or a phase time directional overcurrent relay (e.g., 67) directional toward the Transmission system installed on the high-side of the GSU transformer, including relays installed at the remote end of the line.~~

~~This example uses Option 15a as an example, where PTs and CTs are located in the high-side of the GSU transformer. Example calculations are provided for the case, where potential transformers (PT) and current transformers (CT) are located at the high-side of the GSU transformer and the 0.85 per unit of the line nominal voltage at the high-side of the GSU transformer. Example calculations are also provided for the case where PTs and CTs are located at the remote end of the line and the 0.85 per unit of the line nominal voltage will be at the remote bus location.~~

Calculations at the high-side of the GSU transformer.

Real Power output (P):

$$\text{Eq. } P = GEN_{Synch_nameplate} \times pf$$

(151157)

$$P = 903 \text{ MVA} \times 0.85$$

$$P = 767.6 \text{ MW}$$

Reactive Power output (Q):

$$\text{Eq. } Q = 120\% \times P$$

(152158)

$$Q = 1.20 \times 767.6 \text{ MW}$$

Example Calculations: Options 15a and 16a

$$Q = 921.12 \text{ Mvar}$$

Option 15a, Table 1 – Bus Voltage, calls for a 0.85 per unit of the high-side nominal voltage:

Formatted Table

$$\text{Eq. } V_{bus} = 0.85 \text{ p.u.} \times V_{nom}$$

(453159)

$$V_{bus} = 0.85 \times 345 \text{ kV}$$

$$V_{bus} = 293.25 \text{ kV}$$

Apparent power (S):

$$\text{Eq. } S = P_{\text{Synch,reported}} + jQ$$

(454160)

$$S = 700.0 \text{ MW} + j921.12 \text{ Mvar}$$

$$S = 1157 \angle 52.8^\circ \text{ MVA}$$

Primary current (I_{pri}):

$$\text{Eq. } I_{pri} = \frac{S^*}{\sqrt{3} \times V_{bus}}$$

(455161)

$$I_{pri} = \frac{1157 \angle -52.8^\circ \text{ MVA}}{1.73 \times 293.25 \text{ kV}}$$

$$I_{pri} = 2280.6 \angle -52.8^\circ \text{ A}$$

Secondary current (I_{sec}):

$$\text{Eq. } I_{sec} = \frac{I_{pri}}{CT_{ratio,hv}}$$

(456162)

$$I_{sec} = \frac{2280.6 \angle -52.8^\circ \text{ A}}{\frac{2000}{5}}$$

$$I_{sec} = 5.701 \angle -52.8^\circ \text{ A}$$

To satisfy the 115% margin in Options 15a and 15b:

Formatted Table

$$\text{Eq. } I_{sec \text{ limit}} > I_{sec} \times 115\%$$

(457163)

Example Calculations: Options 15a and 16a

$$I_{sec\ limit} > 5.701 \angle -52.8^\circ A \times 1.15$$

$$I_{sec\ limit} > 6.56 \angle -52.8^\circ A$$

Calculations at the remote end of the line from the plant.

Formatted Table

Real Power output (P):

$$\text{Eq. (164)} \quad P = GEN_{Synch_nameplate} \times pf$$

$$P = 903 \text{ MVA} \times 0.85$$

$$P = 767.6 \text{ MW}$$

Reactive Power output (Q):

$$\text{Eq. (165)} \quad Q = 120\% \times P$$

$$Q = 1.20 \times 767.6 \text{ MW}$$

$$Q = 921.12 \text{ Mvar}$$

Option 15a and 16a, Table 1 – Bus Voltage, calls for a 0.85 per unit of the line nominal voltage at the relay location, in this example the relay location is at the remote substation bus.

$$\text{Eq. (166)} \quad V_{bus_remote_substation} = 0.85 \text{ p. u.} \times V_{nom}$$

$$V_{bus_remote_substation} = 0.85 \times 345 \text{ kV}$$

$$V_{bus_remote_substation} = 293.25 \text{ kV}$$

Apparent power (S):

$$\text{Eq. (167)} \quad S = P_{Synch_reported} + jQ$$

$$S = 700.0 \text{ MW} + j921.12 \text{ Mvar}$$

$$S = 1157 \angle 52.8^\circ \text{ MVA}$$

Primary current (I_{pri}):

$$\text{Eq. (168)} \quad I_{pri} = \frac{S^*}{\sqrt{3} \times V_{bus_remote_substation}}$$

Example Calculations: Options 15a and 16a

$$I_{pri} = \frac{1157 \angle -52.8^\circ \text{ MVA}}{1.73 \times 293.25 \text{ kV}}$$

$$I_{pri} = 2280.6 \angle -52.8^\circ \text{ A}$$

Secondary current (I_{sec}):

$$\text{Eq. (169)} \quad I_{sec} = \frac{I_{pri}}{CT_{CTratio_remote_bus}}$$

$$I_{sec} = \frac{2280.6 \angle -52.8^\circ \text{ A}}{\frac{2000}{5}}$$

$$I_{sec} = 5.701 \angle -52.8^\circ \text{ A}$$

To satisfy the 115% margin in Options 15a and 16a:

$$\text{Eq. (170)} \quad I_{sec \text{ limit}} > I_{sec} \times 115\%$$

$$I_{sec \text{ limit}} > 5.701 \angle -52.8^\circ \text{ A} \times 1.15$$

$$I_{sec \text{ limit}} > 6.56 \angle -52.8^\circ \text{ A}$$

Example Calculations: Options 15b and 16b

Options 15b and 16b represent the calculation for ~~a synchronous generation~~ relays installed on the high-side of the GSU transformer, including relays installed at the remote end of the line, for Elements that connect a GSU transformer to the Transmission system that are used exclusively to export energy directly from a BES generating unit or generating plant ~~connected to synchronous generation.~~

Option 15b represents applying a phase time overcurrent relay (e.g., 51) ~~and/or Phase~~ phase instantaneous overcurrent supervisory elements (e.g., 50) associated with current-based, communication-assisted schemes where the scheme is capable of tripping for loss of communications ~~—installed on the high-side of the GSU transformer—, including relays at the remote end of the line.~~

Option 16b represents applying a phase directional ~~time overcurrent relay or Phase directional instantaneous~~ overcurrent supervisory ~~elements (element (e.g., 67)~~ associated with current-based, communication-assisted schemes where the scheme is capable of tripping for loss of communications ~~—directional toward the Transmission system— and/or a phase directional time overcurrent relay (e.g., 67) directional toward the Transmission system~~ installed on the high-side of the GSU, including relays at the remote end of the line.

~~This example uses Option 15b as a simulation example, where PTs and CTs are located in the high side of the GSU transformer.~~

Example calculations are provided for the case where relays are installed on the high-side of the GSU transformer, including relays installed on the remote end of line. Simulation is used to determine the line voltage at the relay location coincident with the highest Reactive Power output achieved during field-forcing in response to a 0.85 per unit of the line nominal voltage at the remote end of the line prior to field-forcing. This is achieved by modeling a shunt at the remote end (i.e., at the Transmission system) of the line during simulation.

The maximum Reactive Power flow and coincident voltage for both the high-side bus voltage of the GSU transformer and remote end of the line are determined by simulation. The maximum Reactive Power output on the high-side of the GSU transformer and remote end of the line during field-forcing is used as ~~this value~~ these values will correspond to the lowest apparent impedance: at the relay location. The corresponding high-side bus simulated voltage is also used in the calculation. Note that although the excitation limiter reduces the field, the duration of the Reactive Power output achieved for this condition is sufficient to operate a phase overcurrent relay.

Example Calculations: Options 15b and 16b

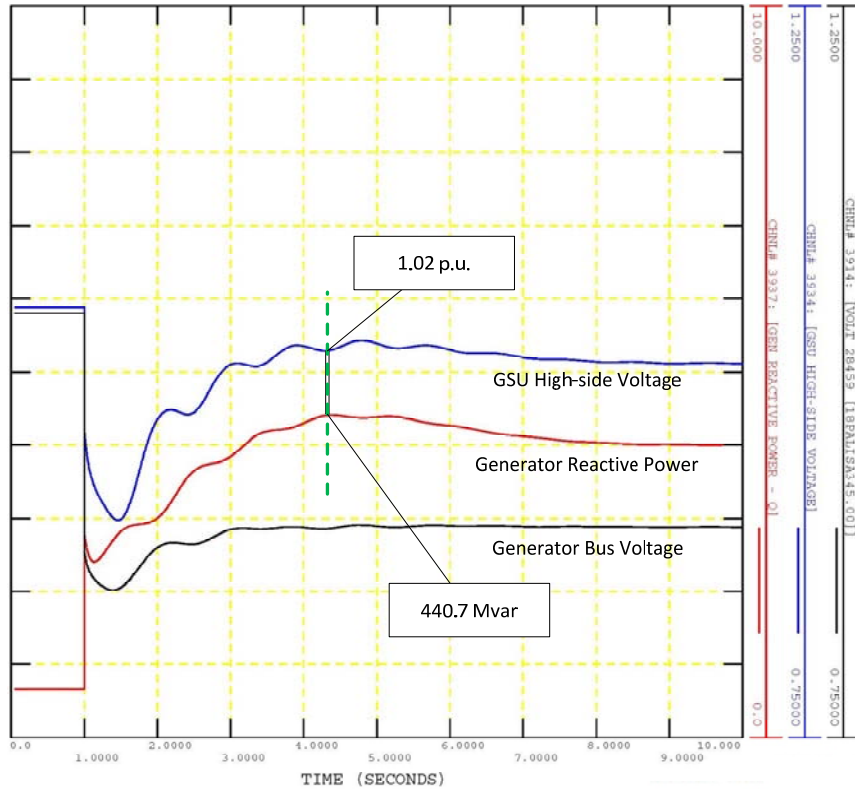

The Reactive Power flow and high side bus voltage are determined by simulation. The maximum Reactive Power output on the high side of the GSU transformer during field forcing is used as this value will correspond to the lowest apparent impedance. The corresponding high side bus voltage is also used in the calculation. Note that although the excitation limiter reduces the field, the duration of the Reactive Power output achieved for this condition is sufficient to operate a phase overcurrent relay.

In this simulation the following values are derived:

$$Q = 703.6 \text{ Mvar}$$

$$V_{bus_simulated} = 0.908 \times V_{nom} = 313.3 \text{ kV}$$

Formatted: Centered

Formatted Table

Example Calculations: Options 15b and 16b

The other value required is the Real Power output which is modeled in the simulation at 100% of the gross MW capability reported to the Transmission Planner. In this case:

$$P_{reported} = 700.0 \text{ MW}$$

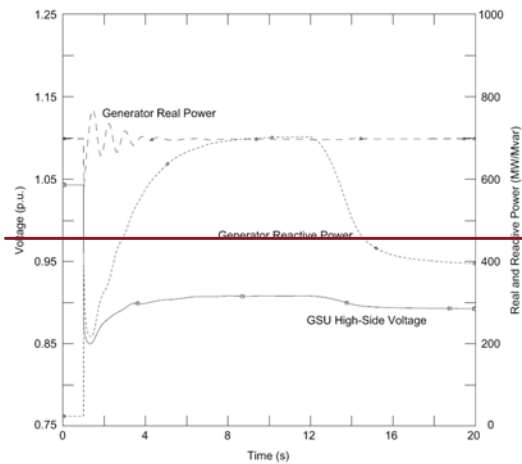

Apparent power (S):

$$\text{Eq. } S = P_{\text{Synch_reported}} + jQ \quad (+58171)$$

$$S = 700.0 \text{ MW} + j703.6 \text{ Mvar}$$

$$S = 992.5 \angle 45.1^\circ \text{ MVA}$$

Primary current (I_{pri}):

$$\text{Eq. } I_{pri} = \frac{S^*}{\sqrt{3} \times V_{bus_simulated}} \quad (+59172)$$

$$I_{pri} = \frac{992.5 \angle -45.1^\circ \text{ MVA}}{1.73 \times 313.3 \text{ kV}}$$

$$I_{pri} = 1831.2 \angle -45.1^\circ \text{ A}$$

Example Calculations: Options 15b and 16b

Secondary current (I_{sec}):

$$\begin{aligned} \text{Eq. } I_{sec} &= \frac{I_{pri}}{CT_{ratio,hv}} \\ (+60173) \quad I_{sec} &= \frac{1831.2 \angle -45.1^\circ A}{\frac{2000}{5}} \\ I_{sec} &= 4.578 \angle -45.1^\circ A \end{aligned}$$

To satisfy the 115% margin in Options 15b and 16b:

$$\begin{aligned} \text{Eq. } I_{sec \text{ limit}} &> I_{sec} \times 115\% \\ (+6174) \quad I_{sec \text{ limit}} &> 4.578 \angle -45.1^\circ A \times 1.15 \\ I_{sec \text{ limit}} &> 5.265 \angle -45.1^\circ A \end{aligned}$$

Example Calculations: Option 17

Option 17 represents the calculation for three asynchronous generation Elements that connect a GSU transformer to the Transmission system that are used exclusively to export energy directly from a BES generating unit or generating plant that is applying a phase distance relay (21) - directional toward the Transmission system. In this application it was assumed 20 Mvar of total static compensation was added.

Real Power output (P):

$$\begin{aligned} \text{Eq. } P_{Asynch} &= 3 \times GEN_{Asynch_nameplate} \times pf \\ (+62175) \quad P_{Asynch} &= 3 \times 40 \text{ MVA} \times 0.85 \\ P_{Asynch} &= 102.0 \text{ MW} \end{aligned}$$

Reactive Power output (Q):

$$\begin{aligned} \text{Eq. } Q_{Asynch} &= MVAR_{static} + MVAR_{gen_static} \\ (+63176) \quad Q_{Asynch} &= (3 \times GEN_{Asynch_nameplate} \times \sin(\cos^{-1}(pf))) \end{aligned}$$

Example Calculations: Option 17

$$Q_{Asynch} = 15 \text{ Mvar} + 5 \text{ Mvar} + (3 \times 40 \text{ MVA} \times \sin(\cos^{-1}(0.85)))$$

$$Q_{Asynch} = 83.2 \text{ Mvar}$$

Option 17, Table 1 – Bus Voltage, calls for a 1.0 per unit of the high-side nominal voltage for the bus voltage (V_{bus}):

$$\text{Eq. } V_{bus} = 1.0 \text{ p.u.} \times V_{nom}$$

(164177)

$$V_{gen} = 1.0 \times 345 \text{ kV}$$

$$V_{gen} = 345.0 \text{ kV}$$

Apparent power (S):

$$\text{Eq. } S = P + jQ$$

(165178)

$$S = 102.0 \text{ MW} + j83.2 \text{ Mvar}$$

$$S = 131.6 \angle 39.2^\circ \text{ MVA}$$

Primary impedance (Z_{pri}):

$$\text{Eq. } Z_{pri} = \frac{V_{bus}^2}{S^*}$$

(166179)

$$Z_{pri} = \frac{(345.0 \text{ kV})^2}{131.6 \angle -39.2^\circ \text{ MVA}}$$

$$Z_{pri} = 904.4 \angle 39.2^\circ \Omega$$

Secondary impedance (Z_{sec}):

$$\text{Eq. } Z_{sec} = Z_{pri} \times \frac{CT_{Asynch_ratio_hv}}{PT_{ratio_hv}}$$

(167180)

$$Z_{sec} = 904.4 \angle 39.2^\circ \Omega \times \frac{\frac{300}{5}}{\frac{2000}{1}}$$

$$Z_{sec} = 904.4 \angle 39.2^\circ \Omega \times 0.03$$

$$Z_{sec} = 27.13 \angle 39.2^\circ \Omega$$

Example Calculations: Option 17

To satisfy the 130% margin in Option 17:

$$\begin{aligned} \text{Eq. (168181)} \quad Z_{\text{sec limit}} &= \frac{Z_{\text{sec}}}{130\%} \\ Z_{\text{sec limit}} &= \frac{27.13 \angle 39.2^\circ \Omega}{1.30} \\ Z_{\text{sec limit}} &= 20.869 \angle 39.2^\circ \Omega \\ \theta_{\text{transient load angle}} &= 39.2^\circ \end{aligned}$$

Assume a Mho distance impedance relay with a maximum torque angle (MTA) set at 85° , and then the maximum allowable impedance reach is:

$$\begin{aligned} \text{Eq. (169182)} \quad Z_{\text{max}} &< \frac{|Z_{\text{sec limit}}|}{\cos(\theta_{\text{MTA}} - \theta_{\text{transient load angle}})} \\ Z_{\text{max}} &< \frac{20.869 \Omega}{\cos(85.0^\circ - 39.2^\circ)} \\ Z_{\text{max}} &< \frac{20.869 \Omega}{0.697} \\ Z_{\text{max}} &< 29.941 \angle 85.0^\circ \Omega \end{aligned}$$

Example Calculations: Options 18 and 19

Option 18 represents the calculation for ~~three-generation Elements that connect a relays on relays installed on the high-side of the~~ GSU transformer, ~~including relays installed on the remote end of line, for Elements that connect a GSU transformer for three asynchronous generators~~ to the Transmission system that are used exclusively to export energy directly from a BES generating unit or generating plant ~~that is,~~

~~Option 18 represents~~ applying a phase time overcurrent (e.g., 51) ~~relay connected to three asynchronous generators and/or phase instantaneous overcurrent supervisory elements (e.g., 50) associated with current-based, communication-assisted schemes where the scheme is capable of tripping for loss of communications installed on the high-side of the GSU transformer, including relays at the remote end of the line.~~

Similarly, Option 19 may also be applied here for the phase directional ~~time~~-overcurrent relays (e.g., 67) directional toward the Transmission system for Elements that connect a GSU transformer, ~~including relays at the remote end of the line~~ to the Transmission system that

Example Calculations: Options 18 and 19

are used exclusively to export energy directly from a BES generating unit or generating plant. In this application it was assumed 20 Mvar of total static compensation was added.

Real Power output (P):

$$\text{Eq. } P = 3 \times GEN_{Asynch_nameplate} \times pf$$

(470183)

$$P = 3 \times 40 \text{ MVA} \times 0.85$$

$$P = 102.0 \text{ MW}$$

Reactive Power output (Q):

$$\text{Eq. } Q = MVAR_{static} + MVAR_{gen_static} + (3 \times GEN_{Asynch_nameplate} \times \sin(\cos^{-1}(pf)))$$

(471184)

$$Q = 15 \text{ Mvar} + 5 \text{ Mvar} + (3 \times 40 \text{ MVA} \times \sin(\cos^{-1}(0.85)))$$

$$Q = 83.2 \text{ Mvar}$$

Options 18 and 19, Table 1 – Bus Voltage, calls for a 1.0 per unit of the high-side nominal voltage (V_{bus}):

$$\text{Eq. } V_{nom} = 1.0 \text{ p.u.} \times V_{nom}$$

(472185)

$$V_{bus} = 1.0 \times 345 \text{ kV}$$

$$V_{bus} = 345 \text{ kV}$$

Apparent power (S):

$$\text{Eq. } S = P + jQ$$

(473186)

$$S = 102.0 \text{ MW} + j83.2 \text{ Mvar}$$

$$S = 131.6 \angle 39.2^\circ \text{ MVA}$$

Primary current (I_{pri}):

$$\text{Eq. } I_{pri} = \frac{S^*}{\sqrt{3} \times V_{bus}}$$

(474187)

Example Calculations: Options 18 and 19

$$I_{pri} = \frac{131.6 \angle -39.2^\circ \text{ MVA}}{1.73 \times 345 \text{ kV}}$$

$$I_{pri} = 220.5 \angle -39.2^\circ \text{ A}$$

Secondary current (I_{sec}):

$$\text{Eq. (475,188)} \quad I_{sec} = \frac{I_{pri}}{CT_{Asynch_ratio_hv}}$$

$$I_{sec} = \frac{220.5 \angle -39.2^\circ \text{ A}}{\frac{300}{5}}$$

$$I_{sec} = 3.675 \angle -39.2^\circ \text{ A}$$

To satisfy the 130% margin in Options 18 and 19:

$$\text{Eq. (476,189)} \quad I_{sec \text{ limit}} > I_{sec} \times 130\%$$

$$I_{sec \text{ limit}} > 3.675 \angle -39.2^\circ \text{ A} \times 1.30$$

$$I_{sec \text{ limit}} > 4.778 \angle -39.2^\circ \text{ A}$$

End of calculations

Rationale:

During development of this standard, text boxes were embedded within the standard to explain the rationale for various parts of the standard. Upon BOT approval, the text from the rationale text boxes was moved to this section.

Rationale for R1:

Requirement R1 is a risk-based requirement that requires the responsible entity to be aware of each protective relay subject to the standard and applies an appropriate setting based on its calculations or simulation for the conditions established in Attachment 1.

The criteria established in Attachment 1 represent short-duration conditions during which generation Facilities are capable of providing system reactive resources, and for which generation Facilities have been historically recorded to disconnect, causing events to become more severe.

The term, “while maintaining reliable fault protection” in Requirement R1 describes that the responsible entity is to comply with this standard while achieving their desired protection goals. Refer to the Guidelines and Technical Basis, Introduction, for more information.