

Standard Development Timeline

This section is maintained by the drafting team during the development of the standard and will be removed when the standard becomes effective.

Development Steps Completed

1. Draft 1 of SAR posted for comment June 11, 2007 – July 10, 2007.
2. SAR approved on August 13, 2007.
3. First posting of revised standard PRC-001-2 on September 11, 2009.
4. Transitioned from a revision of PRC-001-1 to development of PRC-027-1 based on industry comments, Quality Review feedback, and consideration of FERC directives relative to the existing requirements of PRC-001-1.
5. Draft 1 of PRC-027-1 was posted for a 45-day formal comment and initial ballot from May 21 – July 5, 2012.
6. Draft 2 of PRC-027-1 was posted for a 30-day formal comment and successive ballot from November 16 – December 17, 2012.
7. Draft 3 of PRC-027-1 was posted for a 30-day formal comment and successive ballot from June 4 – July 3, 2013.

Description of Current Draft

The System Protection Coordination Standard Drafting Team (SPC-SDT) created a new results-based standard, PRC-027-1, with the stated purpose ‘to coordinate Protection Systems for ~~Interconnected~~Interconnecting Elements, such that Protection System components operate in the ~~desired~~intended sequence during Faults.’ This standard incorporates and clarifies the coordination aspects of Requirements R2 and R3 from PRC-001-2 (formerly R3 and R4 of PRC-001-1). The SPC SDT is requesting a posting for stakeholder comments for a ~~30~~45-day formal comment period ~~with a parallel~~successive~~and~~ ballot.

| Anticipated Actions | Anticipated Date |
|---|--|
| 30 <u>45</u> -day Formal Comment Period with Parallel <u>Successive</u> -Ballot | June <u>September - November</u> 2013 |
| Conduct Recirculation <u>Final</u> Ballot | August <u>December</u> 2013 |
| BOT Adoption | November 2013 <u>February 2014</u> |

Effective Dates:

PRC-027-1 ~~shall become effective on the first day of the first calendar quarter that is 12 months after the date that the standard is approved by an applicable governmental authority or as otherwise provided for in a jurisdiction where approval by an applicable governmental authority is required for a standard to go into effect. Where approval by an applicable governmental authority is not required, the standard shall become effective on the first day of the first calendar quarter that is 12 months after the date the standard is adopted by the NERC Board of Trustees or as otherwise provided for in that jurisdiction.~~ shall become effective on the first day of the first calendar quarter that is 12 months beyond the date that this standard is approved by applicable regulatory authorities. ~~In those jurisdictions where regulatory approval is not required, the standard shall become effective on the first day of the first calendar quarter that is 12 months beyond the date this standard is approved by the NERC Board of Trustees, or as otherwise made effective pursuant to the laws applicable to such ERO governmental authorities. For Interconnected Elements between Canadian Facilities (that recognize the NERC Board of Trustees or other ERO governmental authority approval) and U.S. Facilities (that recognize FERC approval), the effective date shall be the FERC approved effective date.~~

Version History

| Version | Date | Action | Change Tracking |
|---------|------|-----------------------------|-----------------|
| 1 | TBD | Project 2007-06 – PRC-027-1 | New |
| | | | |
| | | | |

Definitions of Terms Used in Standard

This section includes all newly defined or revised terms used in the proposed standard. Terms already defined in the Reliability Standards Glossary of Terms are not repeated here.

The following terms are defined for use only within PRC-027-1, and should remain with the standard upon approval rather than being moved to the NERC Glossary of Terms:

~~Interconnected~~**Interconnecting Element**: A BES Element that electrically joins ~~facilities~~**Facilities**:
 a) owned by:
 a) separate Registered Entities, or
 b) owned by the same Registered Entity that represents multiple functional entity responsibilities (~~Distribution Provider~~**Transmission Owner**, Generator Owner, or ~~Transmission Owner~~**Distribution Provider**).

Protection System Coordination Study: A study that ~~demonstrates~~**documents** existing or proposed Protection Systems operate in the ~~desired~~**intended** sequence for clearing Faults.

When this standard has received ballot approval, the text boxes will be moved to the Application Guidelines Section of the Standard.

A. Introduction

1. **Title:** Protection System Coordination for Performance During Faults
2. **Number:** PRC-027-1
3. **Purpose:** To coordinate Protection Systems for ~~Interconnected~~Interconnecting Elements, such that Protection System components operate in the ~~desired~~intended sequence during Faults.
4. **Applicability:**

4.1. Functional Entities:

- 4.1.1 Transmission Owner
- 4.1.2 Generator Owner
- 4.1.3 Distribution Provider (that own Protection Systems identified in the Facilities section 4.2 below)

~~4.2 Facilities: For the purpose of the requirements contained herein, the following~~

~~Protection Systems owned by each Functional Entity in 4.1 above are those to which these requirements are applicable.:~~

- ~~a) 4.2.1 — Protection Systems~~ installed for the purpose of detecting Faults on ~~Interconnected~~Interconnecting Elements ~~of the BES,~~ and
- ~~a)b)~~ that require coordination for isolating those faulted Elements

5. Background:

On December 7, 2006, the NERC Planning Committee approved the assessment of Reliability Standard PRC-001 – System Protection Coordination, prepared by the NERC System Protection and Control Task Force (SPCTF). The SPCTF noted problems with the applicability to entities and vagueness of requirements in the existing PRC-001-1 reliability standard. The SPCTF concluded that the deficiencies of Reliability Standard PRC-001-1 were magnified by having requirements that addressed coordination of protection functions and capabilities in the operating and planning timeframes. Consequently, the SPCTF recommended that the requirements for the operating horizon and planning horizon be clearly delineated, and possibly divided into two standards.

The NERC Standards Committee approved a Standard Authorization Request that included the modifications noted by the SPCTF for posting on June 5, 2007. The SAR was posted for comment from June 11, 2007 – July 10, 2007, and was subsequently approved.

The Project 2007-06 – System Protection Coordination Standard Drafting Team (SPC-SDT) posted an initial draft of Reliability Standard PRC-001-2 on September 11, 2009 for comments. In that draft, the SPC-SDT attempted to address all issues identified by the SPCTF assessment of PRC-001-1. The SPC-SDT responded to the comments from the initial posting of PRC-001-2, and incorporated pertinent suggestions into the second draft of the standard in the first quarter of 2010. This second draft went through a NERC Quality Review (QR) in December 2010. Based on the results from the QR, and after informal consultations with industry stakeholders, as well as NERC and FERC staffs, the drafting team decided to follow the SPCTF recommendation and focused their knowledge and

expertise on developing a new results-based standard, concentrating on the reliability aspects (the coordination of new and existing protective systems in the planning horizon) associated with Requirements R3 and R4 of PRC-001-1. These aspects of coordination are incorporated and clarified in the proposed Reliability Standard PRC-027-1 – Protection System Coordination for Performance During Faults with the stated purpose:

“To coordinate Protection Systems for ~~Intereconnected~~Interconnecting Elements, such that Protection System components operate in the ~~desired~~intended sequence during Faults.”

~~Additionally, the requirements in the proposed Reliability Standard PRC 027-1 take into account Recommendation 21-C of the Final Report on the August 14, 2003 Blackout in the United States and Canada written by the U.S.-Canada Power System Task Force, which identified the need to address “the appropriate use of time delays in relays,” by requiring that individual intereconnected entities cooperate in designing and setting their Protection Systems to achieve coordination.~~

PRC-001-1 contained a non-specific training requirement (Requirement R1), three operating time frame requirements (Requirements R2, R5 and R6), and two planning requirements (Requirements R3 and R4). The SPC-SDT transferred the responsibility of addressing the operating Requirements R2, R5, and R6 to the drafting team for Project 2007-03 Real-time Operations, charged with revising the TOP group of reliability standards. The Project 2007-03 drafting team retired Requirements R2, R5, and R6 of PRC-001-1 because they addressed data and data requirements that are now included in Reliability Standard TOP-003-2. The NERC Board of Trustees adopted Reliability Standards TOP-003-2 and PRC-001-2 on May 9, 2012.

~~The SPC SDT revised PRC 001-2. Revisions include the removal of Requirements R2 and R3 (formerly Requirements R3 and R4 of PRC 001-1). These two legacy requirements are being retired because the aspects of coordination they address are incorporated in the proposed Reliability Standard PRC 027-1, Protection System Coordination for Performance During Faults. The SPCSDT believes the training aspects of Requirement R1 would be more appropriately addressed by the PER group of Reliability Standards. Consequently, the drafting team has recommended via the NERC Issues Database that the future drafting team charged with revising PER-005-1 incorporate the reliability objective of Requirement R1 into the revised standard. Until that occurs, Requirement R1 of PRC 001-2 must remain in the standard. In an effort to improve PRC 001-2 until it can be fully retired, the drafting team has provided a measure to accompany Requirement R1. The Applicability section was also updated to clarify which Protection Systems are applicable to Requirement R1. (The ‘Facilities’ portion of the Applicability section is identical to the new stakeholder approved and NERC Board of Trustees adopted PRC 005-2.)~~

~~The SPCSDT posted Draft 3 of PRC-027 in June, 2013 for comment and ballot. As part of that posting, the drafting team proposed revisions to PRC-001-2. The revisions were being proposed as an interim step to provide clarity to PRC-001 until it is retired. However, since this last posting, the informal initiative for revising PER-005-1 has transitioned to a formal project, Project 2010-01 Training. The proposed revisions to PER-005-1 address the reliability objective of PRC-001-2, Requirement 1. Proposed Reliability Standard PRC-027-1 incorporates the aspects of coordination in Requirements R2 and R3 of PRC-001-2.~~

Consequently, NERC staff and the SPCSDT are recommending the retirement of PRC-001-2. As such the drafting team is no longer considering changes to PRC-001-2. The disposition of all three PRC-001-2 requirements is outlined in the Mapping Document associated with this project and is posted for stakeholder review. The retirement of PRC-001-2, Requirement R1 is contingent upon the successful ballot and approval of PER-005-2 by the applicable regulatory authorities. The retirement of PRC-001-2, Requirements R2 and R3 are predicated upon the successful ballot and approval of PRC-027-1 by the applicable regulatory authorities.

Other Aspects of Coordination of Protection Systems Addressed by Other Projects:

Fault clearing is the only aspect of protection coordination that is addressed by Reliability Standard PRC-027-1. Other items, such as over/under frequency, over/under voltage, coordination of generating unit or plant voltage regulating controls, and relay loadability are addressed by the following existing standards or current projects:

- Underfrequency Load shedding programs are addressed in PRC-006-1. Generator performance during frequency excursions is being addressed in PRC-024-1 by Project 2007-09 Generator Verification.
- Undervoltage Load shedding programs are addressed by PRC-010-0 and PRC-022-1, and will be improved by Project 2008-02, Undervoltage Load Shedding. Generator performance during voltage excursions is addressed in PRC-024-1 by Project 2007-09, Generator Verification.
- Coordination of Generating Unit or Plant Capabilities, Voltage Regulating Controls, and Protection is ~~being~~ addressed in PRC-019-1 by Project 2007-09, Generator Verification.
- Transmission relay loadability is addressed in PRC-023-2.
- Generator relay loadability ~~is will be~~ addressed in PRC-025-1 by Project 2010-13.2, Phase 2 of Relay Loadability: Generation, in Project 2010-13.2.
- Protective relay response during power swings will be addressed by ~~Phase 3 of~~ Project 2010-13.3, Phase 3 of Relay Loadability: Stable Power Swings.
- Misoperations identified as coordination issues are investigated and have Corrective Action Plans created in accordance with PRC-003-0 and PRC-004-2a, and ~~will be improved~~ are addressed in PRC-004-3 by Project 2010-05.1 Protection Systems: Phase 1 (Misoperations).

The SPC SDT believes that including these other aspects of protection coordination within PRC-027-1 would cause duplication or conflict with requirements and compliance measurements of other standards.

B. Requirements and Measures

Rationale for R1:

Part 1.1 A Protection System Coordination Study (PSCS) is necessary to verify coordination of Protection Systems for existing and new ~~Interconnected~~Interconnecting Elements. The drafting team defines the term “~~Interconnected~~Interconnecting Element” as “A BES Element that electrically joins ~~facilities~~Facilities: a) owned by: ~~a)~~ separate Registered Entities, or b) owned by the same Registered Entity that represents multiple functional entity responsibilities (Distribution Provider, Generator Owner, or Transmission Owner).”

Part 1.1.1 The drafting team believes 60 calendar months is an appropriate period of time for entities to perform the PSCS required where no study exists. The drafting team has no evidence there is widespread miscoordination of Protection Systems associated with ~~Interconnected~~Interconnecting Elements that warrants a shorter time frame.

Part 1.1.2 The drafting team believes that 12 calendar months is an appropriate period of time for entities to perform the studies required when determining, or being notified of, a 10% or greater Fault current change at an interconnecting bus, where such conditions may warrant a new PSCS, or to technically justify why no such study is required. ~~e.g., when a line is protected by dual current differential systems with no backup elements set that are dependent upon Fault current. Refer to the Application Guidelines for Requirement R1 for examples of Protection Systems where technical justifications may be used.~~

Part 1.1.3 The drafting team believes that entities must perform the studies required when proposing or being notified of changes identified in Requirement R3, Part 3.1, or to technically justify why no such study is needed. The drafting team believes the timeframe associated with the requirement for any proposed changes or additions is contingent upon the project’s scope and schedule. Specifying a time frame for performing studies ~~associated with Requirement R3, Part 3.1~~ is unnecessary because notification of such a change may occur weeks or years prior to the change. The initiating entity has the incentive to provide the identified information as soon as possible to ensure timely implementations.

Part 1.1.4 The drafting team believes that entities must perform the studies required when notified of changes identified in Requirement R3, Part 3.3, or to technically justify why no such study is needed. The drafting team believes that six months is an appropriate period of time for entities to perform the studies required or to technically justify why no such study is needed when details of changes are provided associated with Requirement R3 Part 3.3.

Part 1.2 The drafting team believes to properly ensure coordination of Protection Systems associated with ~~Interconnected~~Interconnecting Element(s), all entities need to share the summary of results of a PSCS and assess the study results. The drafting team believes that 90 calendar days is a reasonable time for the entity to provide the results of the PSCS performed in accordance with Requirement R1, Part 1.1 to the other owner(s) of the Protection System(s) associated with the ~~Interconnected~~Interconnecting Element(s).

Note: In cases where a single group performs an overall coordination study for a given ~~Interconnected~~Interconnecting Element; a single document that provides the requirements for a summary of the results of the PSCS ~~would be~~ is sufficient for use by ~~both Registered Entities~~all entities.

R1. Each Transmission Owner, Generator Owner, and Distribution Provider shall: [*Violation Risk Factor: Medium*] [*Time Horizon: Operations Planning, Long-term Planning*]

1.1. Perform a Protection System Coordination Study (PSCS) for each of its ~~Interconnected~~Interconnecting Elements as follows:

1.1.1 Within 60 calendar months after the effective date of this standard, if no PSCS for that ~~Interconnected~~Interconnecting Element exists.

1.1.2 Within 12 calendar months after determining or being notified of a 10% or greater change in Fault current at an interconnecting bus, as described in Requirement R2, or technically justify why such a study is not required.

1.1.3 According to an agreed upon time frame to meet the schedule when proposing or being notified of a change, as described in Requirement R3, Part 3.1, or ~~with~~technically justify why such a study is not required.

~~1.1.3~~1.1.4 Within six calendar months of being notified of a change as described in Requirement R3, Part 3.3~~2~~2, or technically justify why such a study is not required.

1.2. Within 90 calendar days after the completion of each PSCS~~, or the technical justification pursuant to Requirement R1, Part 1.1,~~ provide to the other owner(s) of the Protection System(s) associated with the ~~Interconnected~~Interconnecting Element(s)~~);~~: a summary of the results of each PSCS performed~~pursuant to Requirement R1, Part 1.1,~~(, including, at a minimum, the Protection Systems reviewed, the associated Fault currents~~current(s) used, any issues identified, and any revisions or actions proposed);~~current(s) used, any issues identified, and any revisions or actions proposed); or the technical justification.

M1. Acceptable evidence for Requirement R1, Part 1.1 and its subparts, Parts 1.1.1~~, and~~ 1.1.2, 1.1.3, and 1.1.34 is a dated PSCS, or the summary of the results of each PSCS (hard copy or electronic file formats) demonstrating the time frames specified or agreed to in Parts 1.1.1, 1.1.2, 1.1.3, and 1.1.34 were achieved. Acceptable evidence of a technical justification for not performing a PSCS as specified in Parts 1.1.2, 1.1.3, and 1.1.34 -may include, but is not limited to, documented engineering analyses or assessments that demonstrate the change in Fault current or the proposed system change does not impact any ~~aspects~~aspect of coordination.

M2. Acceptable evidence for Requirement R1, Part 1.2 is dated documentation demonstrating that the summary of the results of each PSCS or the technical justification (hard copy or electronic file formats) were provided within the specified time frame to the owner(s) of the Protection System(s) associated with the ~~Interconnected~~Interconnecting Element(s).

Rationale for R2: This requires a periodic review of Fault currents at the interconnecting bus and providing the results to the applicable entities when changes occur that meet the criteria of Requirement R2. It is important that ~~interconnected~~interconnecting Facility owners are kept aware of changes that could affect proper performance of their Protection Systems. The Transmission Owner is identified as the entity responsible for performing the short circuit studies because they maintain the data necessary to perform the studies. Note: short circuit studies are used to determine the Fault current values at the interconnecting bus where a PSCS exists. These studies are typically performed assuming maximum generation and all Facilities in service.

The drafting team believes 60 calendar months provides the entities flexibility to ~~either technically justify why Fault current does not affect the Protection System coordination, or~~ schedule and perform the activities specified in Requirement R2, Parts 2.1 and 2.2.

~~The drafting team recognizes the coordination of some types of Protection Systems is unaffected by changes in Fault current and, where technically justified, can be exempted from the short circuit review.~~

Part 2.1 The drafting team believes maximum available Fault current values (single line to ground and 3-phase) at the interconnecting bus are necessary quantities needed to review the coordination.

Part 2.2 The drafting team is including this equation to assure a consistent approach is used by each Transmission Owner when calculating the percent change in Fault current values.

Part 2.2.1 The drafting team believes the 30-calendar day time frame is reasonable for providing the Fault current information to the owner(s) of the Protection System(s) associated with the ~~interconnected~~interconnecting Element. The drafting team determined that a change in Fault current of 10% indicates an appropriate point at which to provide this information, based on the fact that Protection Systems are typically set with margins above 10%.

R2. For each ~~interconnected~~interconnecting Element on its System, the Transmission Owner shall, once every 60 calendar months, ~~technically justify why Fault current does not affect the Protection System coordination, or:~~ *[Violation Risk Factor: Medium] [Time Horizon: Operations Planning, Long-term Planning]*

2.1. Perform a short circuit study to determine the present maximum available Fault current values (single line to ground and 3-phase) at ~~theits~~ interconnecting bus(s) where a ~~Protection System Coordination Study (PSCS)~~ is available per-pursuant to Requirement R1.

2.2. Calculate the percent change between the Fault current values (single line to ground and 3-phase for ~~theits~~ interconnecting bus(s) under consideration) used in the most recent PSCS and the Fault current values determined pursuant to Requirement R2, Part 2.1, using the following equation:

$$\% \text{ Change} = \left| \frac{I_{scs} - I_{pscsc}}{I_{pscsc}} \right| \times 100$$

Where: I_{scs} = Fault current value from present short circuit study

And: I_{pscsc} = Fault current value used in the most recent PSCS

2.2.1 Within 30 calendar days after identification of a change of 10% or greater in either single line to ground or 3-phase Fault current, provide the updated Fault current values (I_{scs}) to each owner of the Protection System(s) associated with the ~~interconnected~~interconnecting Element-(s).

~~**M3.**—Acceptable evidence of technical justification for not performing a short circuit study as specified in Requirement R2, could be documented engineering analyses or assessments that demonstrate why Fault current does not impact any aspects of coordination.~~

M4.M3. Acceptable evidence for Requirement R2, Parts 2.1 and 2.2 is dated documentation (hard copy or electronic file formats) that contains the present Fault current values from the short circuit study for each interconnecting bus analyzed, and identifies the percent change from the Fault current values used in the most recent PSCS determined by the equation.

M5.M4. Acceptable evidence for Requirement R2, Part 2.2.1 is dated documentation (hard copy or electronic file formats) that the updated Fault current values (I_{scs}), were provided within the specified timeframe to each owner of the Protection System associated with the ~~Intereconnected~~Interconnecting Element.

Rationale for R3: This requires the transfer of appropriate information to the entities associated with each ~~Intereconnected~~Interconnecting Element due to circumstances identified in Parts 3.1, 3.2, and 3.3.

Part 3.1 The reliability objective of this requirement is to enable the process of conducting PSCSs by ensuring that the information is provided to the owner(s) of the Protection Systems associated with ~~Intereconnected~~Interconnecting Element(s). The drafting team believes that information about any proposed change or addition (pursuant to Requirement R3, Part 3.1) that requires modification of an entity's short circuit model should be provided to other Protection System owners associated with the ~~Intereconnected~~Interconnecting Element. The drafting team believes that specifying a single time frame is not appropriate for the wide variety of conditions that will need to be evaluated. The list provided in the requirement is inclusive, as it comprises either the protective equipment itself or the power system Elements that affect the coordination of Protection Systems. Examples of changes to generator units that result in impedance changes could include replacements and re-ratings. This requirement also pertains to changes identified as a result of studies performed in Requirement 1, Part 1.1.

Part 3.2 The purpose of this requirement is to provide a means for an entity to receive the requested information in a timely manner in order to perform a PSCS, as required in Requirement 1, Parts 1.1.1, 1.1.2, 1.1.3, and 1.1.34. The drafting team believes 30 calendar days after receipt of the request is a sufficient amount of time to provide this information. The requirement also provides some flexibility for the parties involved to determine an otherwise agreed-to schedule, if appropriate.

Part 3.3 The drafting team believes 30 calendar days is sufficient time to provide the information.

Note: In cases where a single group performs an overall coordination study for a given Interconnecting Element; a single document that describes the information listed in Requirement R3, Parts 3.1 and 3.3 below is sufficient for use by all entities.

R3. Each Transmission Owner, Generator Owner, and Distribution Provider shall provide to each Transmission Owner, Generator Owner, and Distribution Provider connected to the same ~~Intereconnected~~Interconnecting Element: [*Violation Risk Factor: Medium*] [*Time Horizon: Operations Planning, Long-term Planning*]

3.1. Details for any proposed change or addition listed below; either at an existing or new Facility associated with the ~~Intereconnected~~Interconnecting Element; or at other Facilities when the proposed change modifies the conditions used in the coordination of Protection Systems associated with the ~~Intereconnected~~Interconnecting Element(s).

- New installation, replacement with different types, or modification of protective relays or protective function settings, communication systems, current transformer ratios and voltage transformer ratios
- Changes to a transmission system Element that alter any sequence or mutual coupling impedance
- Changes to generator unit(s) that result in a change in impedance

- Changes to the generator step-up transformer(s) that result in a change in impedance

3.2. Requested information related to the coordination of Protection Systems associated with an ~~Interconnected~~Interconnecting Element, within 30 calendar days of receiving a request or according to an agreed-upon schedule.

3.3. Within 30 calendar days of making the change, details of permanent changes made to Protection Systems associated with the Interconnecting Element during Misoperation investigations, commissioning, maintenance activities, or emergency replacements made due to failures of Protection System components.

~~M6:~~M5. Acceptable evidence for Requirement R3, Part 3.1 may include, but is not limited to, documentation (hard copy or electronic file formats) demonstrating that a summary of the future project or technical specifications of the proposed changes (e.g., project schedule, protective relaying scheme types and settings) as identified in the bulleted list, was provided to each responsible entity connected to the same ~~Interconnected~~Interconnecting Element.

~~M7:~~M6. Acceptable evidence for Requirement R3, Part 3.2 is dated documentation (hard copy or electronic file formats) demonstrating the requested information was provided according to the agreed-upon schedule, or within 30 calendar days absent such an agreement.

~~M8:~~M7. Acceptable evidence for Requirement R3, Part 3.3 is dated documentation (hard copy or electronic file formats) demonstrating the information pertinent to the permanent changes made was provided within 30 calendar days.

Rationale for R4: This requirement ensures owner(s) of Protection System(s) associated with ~~Interconnected~~Interconnecting Elements ~~affirm~~confirm that the Protection System(s) applied ~~are acceptable per~~were reviewed and a response was provided to the ~~conditions identified in Parts 4.1 and 4.2~~other owner(s). The review assures that the ~~owners of Protection Systems associated with the affected Interconnecting Element are aware of the changes and have responded with comments if necessary.~~

~~Part 4.1~~ The drafting team believes 90 calendar days is a reasonable time for the owner(s) of Protection System(s) associated with ~~Interconnected~~Interconnecting Elements to review the summary results of a PSCS or the technical justification and respond. Note: ~~Per~~Pursuant to Requirement R1, Part 1.2, at a minimum, the summary of the results of a PSCS must include the Protection Systems reviewed, the associated Fault currents used, any issues identified, and any revisions or actions proposed. The response should indicate ~~acceptance with the review results/conclusions; or rejection of or disagreement with the review results/conclusions~~PSCS or the technical justification were reviewed and offer of suggestions/modifications to resolve, if applicable, any identified ~~coordination~~ issues.

Note: The drafting team recognizes there could be situations where one owner may not agree with the other owner's protection philosophy but they ~~accept the proposed changes since~~ can confirm that there were identified coordination issues ~~were identified~~.

~~Part 4.2~~ The drafting team believes that ~~proposed changes or modifications (including project schedules) to Facilities associated with the Interconnected Element, as described in Requirement R3, Part 3.1, or modifications suggested in Requirement R4, Part 4.1 must be communicated and accepted prior to the in-service date.~~ Acceptance assures that ~~the coordination of Protection Systems associated with the affected Interconnected Element is achieved.~~ Note: In cases where a single group performs an overall coordination study for a given Interconnecting Element; a single document that describes the information listed in Requirement R3, Parts 3.1 and 3.3 below is sufficient for use by all entities.

R4.—Each Transmission Owner, Generator Owner, and Distribution Provider that received a summary of the results of a PSCS or a technical justification explaining why a PSCS is not

~~required (pursuant to Requirement R1, Part 1.2) shall: [Violation Risk Factor: Medium] [Time Horizon: Operations Planning]~~

~~R5.R4. Within, within~~ 90 calendar days after receipt, or according to an agreed upon schedule, review the summary ~~of the results of a PSCS (per Requirement R1, Part 1.2) or the technical justification,~~ and respond to the other owner(s): ~~either: [Violation Risk Factor: Medium] [Time Horizon: Operations Planning, Long-term Planning]~~

- ~~• Accepting~~ Confirming that the results, or
- ~~• Rejecting~~ summary of the results was reviewed and suggesting modifications to resolve any identified no coordinaticoordination issues were identified, on issues.
- ~~• Prior to implementing any proposed change(s) or modifications associated with Requirement R3, Part 3.1 or Requirement 4, Part 4.1, affirm that the other owner(s) of each Facility associated with the affected Interconnected Element have accepted the Protection System(s) changes including the resolution of any identified coordination issues.~~
- ~~• Confirming that the summary of the results was reviewed and any identified coordination issue(s) were noted, or~~
- ~~• Confirming that a technical justification was reviewed and no issue(s) were identified, or~~
- ~~• Confirming that a technical justification was reviewed and any identified issue(s) were noted~~

~~M9.M8.~~ Acceptable evidence for Requirement R4, ~~Part 4.1~~ is dated documentation (hardcopy or electronic file formats) demonstrating that response was provided according to the agreed-upon schedule, or within 90 calendar days absent such an agreement.

Rationale for R5: This requirement ensures owner(s) of Protection System(s) associated with Interconnecting Elements have communicated and addressed any identified coordination issues prior to implementing changes in the Protection System(s) (i.e., the in-service date of the Protection System(s)).

~~R5.~~ Each Transmission Owner, Generator Owner, and Distribution Provider that received a response pursuant to Requirement R4 shall address any identified coordination issue(s) prior to implementing any proposed change(s) or addition(s) to the Protection System(s) associated with the Interconnecting Element(s). ~~[Violation Risk Factor: Medium] [Time Horizon: Operations Planning, Long-term Planning]~~

~~M10.M9.~~ Acceptable evidence for Requirement ~~R4, Part 4.2~~R5 is dated documentation (hardcopy or electronic file formats) demonstrating that, a response pursuant to Requirement R4 was received and that any identified coordination issues were addressed prior to implementation of any proposed Protection System(s) changes or ~~modifications, communications (e.g. email acknowledgements) of those changes were completed, and any identified coordination issues were resolved and accepted~~additions.

C. Compliance

1. Compliance Monitoring Process

1.1. Compliance Enforcement Authority

As defined in the NERC Rules of Procedure, “Compliance Enforcement Authority” means NERC or the Regional Entity in their respective roles of monitoring and enforcing compliance with the NERC Reliability Standards.

1.2. Evidence Retention

The following evidence retention periods identify the period of time an entity is required to retain specific evidence to demonstrate compliance. For instances where the evidence retention period specified below is shorter than the time since the last audit, the Compliance Enforcement Authority may ask an entity to provide other evidence to show that it was compliant for the full time period since the last audit.

The Transmission Owner, Generator Owner and Distribution Provider that owns a Protection System associated with an ~~Interconnected~~Interconnecting Element shall each keep data or evidence to show compliance with Requirements R1, R2, R3, R4, and R4R5, and Measures M1 through ~~M10~~M9, since the last audit, unless directed by its Compliance Enforcement Authority to retain specific evidence for a longer period of time as part of an investigation.

If a Transmission Owner, Generator Owner or Distribution Provider that owns a Protection System at a Facility associated with an ~~Interconnected~~Interconnecting Element is found non-compliant, it shall keep information related to the non-compliance until mitigation is complete and approved, or for the time specified above, whichever is longer.

The Compliance Enforcement Authority shall keep the last audit records and all requested and submitted subsequent audit records.

1.3. Compliance Monitoring and Assessment Processes:

- Compliance Audit
- Self-Certification
- Spot Checking
- Compliance Investigation
- Self-Reporting
- Complaint

1.4. Additional Compliance Information

None

Table of Compliance Elements

| R # | Time Horizon | VRF | Violation Severity Levels | | | |
|-----|---|--------|--|---|---|---|
| | | | Lower VSL | Moderate VSL | High VSL | Severe VSL |
| R1 | Operations Planning, Long-term Planning | Medium | <p>The responsible entity performed a Protection System Coordination Study on an Interconnected<u>Interconnecting</u> Element as required in Requirement R1, Part 1.1.1, but was late by less than or equal to 30 calendar days.</p> <p style="text-align: center;">OR</p> <p>The responsible entity performed a Protection System Coordination Study at an interconnecting bus as required in Requirement R1, Parts <u>1.1.2, 1.1.3, and 1.1.4</u>, or technically justified why a study was not required, but was late by less than or equal to 30 calendar days.</p> <p style="text-align: center;">OR</p> <p style="text-align: center;"><u>OR</u></p> <p>The responsible entity provided <u>a summary of the results of each</u> Protection System Coordination Study results<u>or a technical justification</u> in accordance</p> | <p>The responsible entity performed a Protection System Coordination Study on an Interconnected<u>Interconnecting</u> Element as required in Requirement R1, Part 1.1.1, but was late by more than 30 calendar days but less than or equal to 60 calendar days.</p> <p style="text-align: center;">OR</p> <p>The responsible entity performed a Protection System Coordination Study at an interconnecting bus as required in Requirement R1, Parts <u>1.1.2, 1.1.3, and 1.1.4</u>, or technically justified why a study was not required, but was late by more than 30 calendar days but less than or equal to 45 calendar days.</p> <p style="text-align: center;">OR</p> <p>The responsible entity provided <u>a summary of the results of each</u> Protection System Coordination Study results<u>or a technical justification</u> in accordance with Requirement R1, Part 1.2, but was late by more than</p> | <p>The responsible entity performed a Protection System Coordination Study on an Interconnected<u>Interconnecting</u> Element as required in Requirement R1, Part 1.1.1, but was late by more than 60 calendar days but less than or equal to 90 calendar days.</p> <p style="text-align: center;">OR</p> <p>The responsible entity performed a Protection System Coordination Study at an interconnecting bus as required in Requirement R1, Parts <u>1.1.2, 1.1.3, and 1.1.4</u>, or technically justified why a study was not required, but was late by more than 45 calendar days but less than or equal to 60 calendar days.</p> <p style="text-align: center;">OR</p> <p>The responsible entity provided <u>a summary of the results of each</u> Protection System Coordination Study results<u>or a technical justification</u> in accordance with Requirement R1, Part 1.2, but was late by more than</p> | <p>The responsible entity performed a Protection System Coordination Study on an Interconnected<u>Interconnecting</u> Element as required in Requirement R1, Part 1.1.1, but was late by more than 90 calendar days.</p> <p style="text-align: center;">OR</p> <p>The responsible entity performed a Protection System Coordination Study at an interconnecting bus as required in Requirement R1, Parts <u>1.1.2, 1.1.3, and 1.1.4</u>, or technically justified why a study was not required but was late by more than 60 calendar days.</p> <p style="text-align: center;">OR</p> <p style="text-align: center;"><u>The responsible entity provided the Protection System</u></p> |

| R # | Time Horizon | VRF | Violation Severity Levels | | | |
|-----|--------------|-----|--|--|--|--|
| | | | Lower VSL | Moderate VSL | High VSL | Severe VSL |
| | | | with Requirement R1, Part 1.2, but was late by less than or equal to 10 calendar days. | 10 calendar days but less than or equal to 20 calendar days. | 20 calendar days but less than or equal to 30 calendar days. | <p>Coordination Study</p> <p><u>OR</u></p> <p><u>The responsible entity provided a summary of the results of each Protection System Coordination Study or a technical justification</u> in accordance with Requirement R1, Part 1.2, but was late by more than 30 calendar days.</p> <p><u>OR</u></p> <p>The responsible entity failed to perform a Protection System Coordination Study on an Interconnected<u>Interconnecting</u> Element in accordance with Requirement R1, Parts 1.1.1, 1.1.2, <u>1.1.3</u>, or 1.1.34.</p> <p><u>OR</u></p> <p>The responsible entity failed to technically justify why a study was not required in accordance with Requirement R1, Parts 1.1.2, <u>1.1.3</u>, or 1.1.34.</p> <p><u>OR</u></p> <p>The responsible entity failed to provide <u>a summary of the results of each</u> Protection System Coordination Study</p> |

| R # | Time Horizon | VRF | Violation Severity Levels | | | |
|-----|---|--------|---|--|--|---|
| | | | Lower VSL | Moderate VSL | High VSL | Severe VSL |
| | | | | | | results or a technical justification in accordance with Requirement R1, Part 1.2. |
| R2 | Operations Planning, Long-term Planning | Medium | <p>For an Interconnected Element on its System, the Transmission Owner technically justified why Fault current does not affect the Protection System coordination, as required in Requirement R2, but was late by less than or equal to 30 calendar days.</p> <p>OR</p> <p>The Transmission Owner performed a short circuit study, as required in Requirement R2, Part 2.1, but was late by less than or equal to 30 calendar days.</p> | <p>For an Interconnected Element on its System, the Transmission Owner technically justified why Fault current does not affect the Protection System coordination, as required in Requirement R2, but was late by more than 30 calendar days but less than or equal to 60 calendar days.</p> <p>OR</p> <p>The Transmission Owner performed a short circuit study as required in Requirement R2, Part 2.1, but was late by more than 30 calendar days but less than or equal to 60 calendar days.</p> | <p>For an Interconnected Element on its System, the Transmission Owner technically justified why Fault current does not affect the Protection System coordination, as required in Requirement R2, but was late by more than 60 calendar days but less than or equal to 90 calendar days.</p> <p>OR</p> <p>The Transmission Owner performed a short circuit study as required in Requirement R2, Part 2.1, but was late by more than 60 calendar days but less than or equal to 90 calendar days.</p> | <p>For an Interconnected Element on its System, the Transmission Owner technically justified why Fault current does not affect the Protection System coordination, as required in Requirement R2, but was late by more than 90 calendar days.</p> <p>OR</p> <p>The Transmission Owner performed a short circuit study as required in Requirement R2, Part 2.1, but was late by more than 90 calendar days.</p> <p>OR</p> <p>The Transmission Owner failed to perform a short circuit study, as required in Requirement R2, Part 2.1.</p> <p>OR</p> <p>The Transmission Owner failed to calculate the percent change between the Fault</p> |

| R # | Time Horizon | VRF | Violation Severity Levels | | | |
|-----|---|--------|--|---|---|--|
| | | | Lower VSL | Moderate VSL | High VSL | Severe VSL |
| | | | <p>OR</p> <p>The Transmission Owner provided the owner(s) of the Facility associated with the Interconnected<u>Interconnecting</u> Element, the changes in Fault currents, as required in Requirement R2, Part 2.2.1, but was late by less than or equal to 10 calendar days.</p> | <p>OR</p> <p>The Transmission Owner provided the owner(s) of the Facility associated with the Interconnected<u>Interconnecting</u> Element, the changes in Fault currents, as required in Requirement R2, Part 2.2.1, but was late by more than 10 calendar days but less than or equal to 20 calendar days.</p> | <p>OR</p> <p>The Transmission Owner provided the owner(s) of the Facility associated with the Interconnected<u>Interconnecting</u> Element, the changes in Fault currents, as required in Requirement R2, Part 2.2.1, but was late by more than 20 calendar days but less than or equal to 30 calendar days.</p> | <p>currents, according to the equation designated in Requirement R2, Part 2.2.</p> <p>OR</p> <p>The Transmission Owner provided the owner(s) of the Facility associated with the Interconnected<u>Interconnecting</u> Element, the changes in Fault currents, as required in Requirement R2, Part 2.2.1, but was late by more than 30 calendar days.</p> <p>OR</p> <p>The Transmission Owner failed to provide the owner(s) of the Facility associated with the Interconnected<u>Interconnecting</u> Element, the updated Fault current values, as required in Requirement R2, Part 2.2.1.</p> |
| R3 | Operations Planning, Long-term Planning | Medium | | | | <p>The responsible entity failed to provide the owner(s) of the Facility associated with the Interconnected<u>Interconnecting</u> Element, details for any proposed change or addition identified in Requirement R3, Part 3.1.</p> <p>OR</p> |

| R # | Time Horizon | VRF | Violation Severity Levels | | | |
|-----|--|--------|---|---|---|---|
| | | | Lower VSL | Moderate VSL | High VSL | Severe VSL |
| | | | <p>The responsible entity provided the requested information required in Requirement R3, Part 3.2, but was late by less than or equal to 10 calendar days.</p> <p style="text-align: center;">OR</p> <p>The responsible entity provided the information required in Requirement R3, Part 3.3, but was late by less than or equal to 10 calendar days.</p> | <p>The responsible entity provided the requested information required in Requirement R3, Part 3.2, but was late by more than 10 calendar days but less than or equal to 20 calendar days.</p> <p style="text-align: center;">OR</p> <p>The responsible entity provided the information required in Requirement R3, Part 3.3, but was late by more than 10 calendar days but less than or equal to 20 calendar days.</p> | <p>The responsible entity provided the requested information required in Requirement R3, Part 3.2, but was late by more than 20 calendar days but less than or equal to 30 calendar days.</p> <p style="text-align: center;">OR</p> <p>The responsible entity provided the information required in Requirement R3, Part 3.3, but was late by more than 20 calendar days but less than or equal to 30 calendar days.</p> | <p>The responsible entity provided the requested information required in Requirement R3, Part 3.2, but was late by more than 30 calendar days.</p> <p style="text-align: center;">OR</p> <p>The responsible entity provided the information required in Requirement R3, Part 3.3, but was late by more than 30 calendar days.</p> <p style="text-align: center;">OR</p> <p>The responsible entity failed to provide the information required in Requirement R3, Part 3.3.</p> |
| R4 | <u>Operations Planning, Long-term Planning</u> Operations Planning | Medium | <p>The responsible entity responded in more than 90 calendar days but less than or equal to 100 calendar days following the receipt of the <u>Protection System Coordination Study summary of the results of the Protection System Coordination Study or technical justification</u>, as required in Requirement R4, Part 4.1.</p> | <p>The responsible entity responded in more than 100 calendar days but less than or equal to 110 calendar days following the receipt of the <u>summary results of the Protection System Coordination Study summary of the results or technical justification</u>, as required in Requirement R4, Part 4.1.</p> | <p>The responsible entity responded in more than 110 calendar days but less than or equal to 120 calendar days following the receipt of the <u>summary results of the Protection System Coordination Study summary of the results or technical justification</u>, as required in Requirement R4, Part 4.1.</p> | <p>The responsible entity responded in more than 120 calendar days following the receipt of the <u>summary results of the Protection System Coordination Study summary of the results or technical justification</u>, as required in Requirement R4, Part 4.1.</p> <p style="text-align: center;">OR</p> <p>The responsible entity failed</p> |

| R # | Time Horizon | VRF | Violation Severity Levels | | | |
|-----|--|---------------|---------------------------|--------------|----------|---|
| | | | Lower VSL | Moderate VSL | High VSL | Severe VSL |
| | | | | | | <p>to review the summary results of the Protection System Coordination Study <u>summary of the results -or the technical justification</u> provided to them in accordance with Requirement R4, Part 4.1.</p> <p>OR</p> <p>The responsible entity failed to respond to the other owners(s) in accordance with Requirement R4, Part 4.1.</p> <p>OR</p> <p>The responsible entity failed to affirm that the other owner(s) of each Facility associated with the affected Interconnected Element accepted the Protection System(s) changes including the resolution of any identified coordination issues, prior to implementation of those changes, as required in Requirement R4, Part 4.2.</p> |
| R5 | <u>Operations Planning, Long-term Planning</u> | <u>Medium</u> | | | | <p>The responsible entity failed to address any identified <u>coordination issue(s), prior to implementing any proposed change(s) or addition(s) to the Protection System(s) associated with the Interconnecting Element(s) in</u></p> |

| R # | Time Horizon | VRF | Violation Severity Levels | | | |
|-----|--------------|-----|---------------------------|--------------|----------|--|
| | | | Lower VSL | Moderate VSL | High VSL | Severe VSL |
| | | | | | | <u>accordance with Requirement R5.</u> |

D. Regional Variances

None.

E. Interpretations

None.

F. Associated Documents

None.

Guidelines and Technical Basis

Purpose:

To coordinate Protection Systems for ~~Interconnected~~Interconnecting Elements, such that Protection System components operate in the ~~desired~~intended sequence during Faults.

This standard requires that separate Registered Entities communicate with each other to coordinate Protection System components on existing ~~Interconnected~~Interconnecting Elements; and communicate with each other prior to the energization of new or modified Protection Systems associated with ~~Interconnected~~Interconnecting Elements. The goal of the coordination is to verify that the Protection Systems intended for sensing Faults will operate in the ~~desired~~intended sequence for internal and external Faults on the ~~Interconnected~~Interconnecting Element.

Requirement R1:

This requirement directs the applicable entities to perform a Protection System Coordination Study (PSCS) for every ~~Interconnected~~Interconnecting Element to verify coordination of existing Protection Systems where no recent study exists; or when Facility configuration changes are made, or where Fault current changes of 10% or more have occurred. In developing the language to define a PSCS, the System Protection Coordination Standard Drafting Team (SPC SDT) considered various reference books discussing protective relaying theory and application, along with the following description of “coordination of protection” from the pending revision of IEEE C37.113, Guide for Protective Relay Applications to Transmission Lines:

“The process of choosing current or voltage settings, or time delay characteristics of protective relays such that their operation occurs in a specified sequence so that interruption to customers is minimized and least number of power system elements are isolated following a system fault.”

Using the reference material cited above as guidance, the drafting team defined the term Protection System Coordination Study (PSCS) for use within the PRC-027-1 Reliability Standard as:

“A study that ~~demonstrates~~documents existing or proposed Protection Systems operate in the ~~desired~~intended sequence for clearing Faults.”

PSCSs comprise a variety of assessments and underlying database activities that cumulatively serve to provide verification that Protection Systems will function as designed. Typical database activities performed during these studies include assembling impedance data for Fault studies and modeling Protection Systems. System conditions used in PSCSs include maximum generation with the transmission system under normal operating conditions and under single contingency conditions. Ultimately, the particular studies performed depend on the protective relays installed, their application, and the Protection System philosophies of each Transmission Owner, Generator Owner, and Distribution Provider. These studies may include graphical coordination of protection characteristics on time-current or impedance graphs; relay scheme simulation studies using sequence of operations during pre-defined Faults; and

sensitivity studies to confirm effective reaches, sufficient operating parameters (energy or operating torque), and adequate directional polarizing quantities.

Part 1.1.1:

The drafting team believes applicable entities should have a documented PSCS for each ~~Interconnected~~Interconnecting Element to validate the Protection Systems associated with those ~~Interconnected~~Interconnecting Elements perform in a manner consistent with the purpose of this Standard. Additionally, the drafting team believes that 60 calendar months is an appropriate amount of time for entities to perform the initial studies expected under this requirement. This period considers the time some entities may require to create project scopes, acquire proposals, and secure contracts to hire external resources that may be needed to perform the studies. The drafting team also has no evidence there is widespread miscoordination between owners of Facilities associated with ~~Interconnected~~Interconnecting Elements that might warrant a shorter time frame for the studies to be performed. Protection Systems are continually challenged by Faults on the BES, but records collected for Reliability Standard PRC-004 do not indicate that lack of coordination was the predominate root cause of reported Misoperations.

~~Parts 1.1.2 and 1.1.3 further direct that PSCSs must be completed under the following two circumstances:~~

Part 1.1.2:

After notification of an identified 10% or greater change in Fault current (single line to ground and 3-phase for the interconnecting bus(s) under consideration) used in the most recent PSCS and the Fault current values determined pursuant to Requirement R2, Part 2.1), the notified entities must perform a new PSCS of the ~~Interconnected~~Interconnecting Element or document why a study is not required. The drafting team recognizes that, based on the Protection Systems installed (e.g., current differential), a 10% or greater change in Fault current may not necessitate a new PSCS be performed; therefore this part of the requirement includes the statement, "...or technically justify why such a study is not required." The drafting team believes the 12-calendar month time frame associated with this requirement represents a reasonable period to perform the studies that are required after identification by the 60-calendar month Fault current review.

Part 1.1.3:

After proposing or being notified of a change at a Facility associated with the ~~Interconnected~~Interconnecting Element, entities must perform a new PSCS, or technically justify why such a study is not required. The drafting team recognizes that, based on the scope of the proposed or notified change and/or the Protection Systems installed (e.g., current differential), the change may not necessitate a new PSCS be performed; therefore this part of the requirement includes the statement, "...or technically justify why such a study is not required." The drafting team believes the timeframe associated with

performing a PSCS for any proposed changes or additions is contingent upon the project's scope and schedule. Specifying a time frame for performing studies associated with Requirement R3, Part 3.1 is unnecessary because notification of such a change may occur weeks or years prior to the change due to the wide variety of conditions that may be associated with a particular change. The drafting team sees the entity initiating any change as having the incentive to move this along in a timely fashion in order to both keep the associated project on schedule and confirm the changes are acceptable "prior to the in-service date," as stipulated by Requirement ~~R4, R5~~.

Part ~~1.1.4.2~~:

~~After being notified of a change at a Facility associated with the Interconnecting Element associated with Requirement R3, Part 3.3, entities must perform a new PSCS, or technically justify why such a study is not required. The drafting team recognizes that, based on the scope of the notified change and/or the Protection Systems installed (e.g., current differential), the change may not necessitate a new PSCS be performed; therefore this part of the requirement includes the statement, "...or technically justify why such a study is not required."~~ The drafting team believes that six calendar months is an appropriate period of time for entities to perform the studies required, or to technically justify why no such study is needed, ~~when details of changes are provided associated with Requirement R3 Part 3.3.~~

Examples of Protection Systems where technical justifications may be used include:

1. Differential elements
2. Distance elements where infeed is not used in determining reach for the protection scheme.
3. Supervised overcurrent elements enabled by:
 - Loss of potential condition
 - Some communication assisted tripping
 - Switch-Onto-Fault (SOTF)
4. Reverse power, definite time &/or time overcurrent elements:
 - Designed to coordinate during maximum generation with the transmission system under normal operating conditions and under single contingency conditions regardless of Fault current.
 - Designed for the protection of equipment other than for the purpose of detecting Faults on BES Elements even though those relays that may operate for such Faults, but are not installed specifically for that purpose (i.e. transformer overcurrent, reverse power, etc.).

Requirement R1, Part 1.2 directs the entity performing the PSCS to provide a summary of the study results or a technical justification to the affected ~~Interconnected~~ Interconnecting Element owner(s).- The drafting team believes that 90 calendar days is a reasonable time for the entity to provide the results of the PSCS it

Application Guidelines

performed to the other owner(s) of the Protection System(s) associated with the ~~Interconnected~~Interconnecting Element(s). (Note: In cases where a single group performs an overall coordination study for a given ~~Interconnected~~Interconnecting Element; a single document that meets the requirements for a summary of the results of the PSCS would be sufficient for use by both Registered Entities.) ~~As guidance, the drafting team lists the~~The following inputs and results of a PSCS ~~that may~~must be included in the summary provided pursuant to this requirement:

1. A listing of the Protection System(s) owned by the entity performing the study that are adjacent to the bus or Element at the Facility, and which were reviewed for coordination of protective relays as part of the study, including the contingencies used in the evaluation.
2. A listing of the single-line-to-ground and 3-phase Fault currents for the bus or Element at the Facility under study.
3. A listing of any issues associated with the relay settings of the other owner(s) at the Facility that were identified by the study.
4. Any proposed revisions to a Protection System or its protective relay settings that were identified by the study.

Requirement R2:

The drafting team investigated various inputs that would trigger a review of the existing PSCSs and determined, through the experience of the drafting team members, along with informal surveys of several regional protection and control committees, that variations in Fault currents of 10% or more are an appropriate indicator that an updated PSCS may be necessary. These variations could result from the accumulation of incremental changes over time. This requirement mandates the Transmission Owner ~~either provide a technical justification stating why Fault current does not affect the Protection System coordination of a specific Interconnected Element or~~ perform a periodic review of Fault currents.

~~Examples of Protection Systems where technical justifications may be used include:~~

- ~~5. Differential elements~~
- ~~6. Distance elements where infeed is not used in determining reach for the protection scheme.~~
- ~~7. Supervised overcurrent elements enabled by:~~
 - ~~• Loss of potential condition~~
 - ~~• Some communication assisted tripping~~
 - ~~• Switch Onto Fault (SOTF)~~
- ~~8. Reverse power, definite time &/or time overcurrent elements:~~
 - ~~• Designed to coordinate during maximum generation with the transmission system under normal operating conditions and under single contingency conditions regardless of Fault current.~~

- ~~• Designed for the protection of equipment other than for the purpose of detecting Faults on BES Elements even though those relays that may operate for such Faults, but are not installed specifically for that purpose (i.e. transformer overcurrent, reverse power, etc.).~~

The short circuit study provides the Fault current values used to calculate the percent change between the most recent PSCS and the present Fault current values indicated by the short circuit study performed pursuant to Requirement R2, Part 2.1. This calculation is necessary to identify Fault current changes that must be communicated in accordance with Requirement R2, Part 2.2. Short circuit studies are typically performed assuming maximum generation and all Facilities in service.

The drafting team believes that 60 calendar months is an appropriate interval for ~~technically justifying why Fault currents do not affect the Protection System coordination of a specific Interconnected Element, or for~~ reviewing Fault currents. The drafting team believes studies associated with changes that would affect the coordination in less than 60 calendar months would be triggered by conditions addressed by other requirements in this standard.

Requirement R2, Part 2.2.1 further directs the Transmission Owner to, within 30 calendar days, inform each owner of the Facility associated with the ~~Interconnected~~Interconnecting Element when short circuit studies indicate that 10% changes in Fault current have occurred at the interconnecting bus(s). The drafting team believes the 30-calendar day time frame associated with this requirement is reasonable for providing the Fault current information to the ~~interconnected~~interconnecting entity(s) and is consistent with other NERC reliability standards.

In Requirement R2, the Transmission Owner is identified as the functional entity responsible for performing the short circuit studies because they maintain the data required to perform the studies. Generator data (including data provided by Distribution Providers) is incorporated into the Transmission Owners' short circuit models.

|

Requirement R3:

This directs the registered functional entity initiating any proposed change or addition to provide the details to the other affected entities of the ~~Intereonected~~Interconnecting Element so that the owners can evaluate the impact to their Protection Systems due to proposed changes. Documentation provided to these other owners may include, but is not limited to, power system configurations, protection schemes, schematics, instrument transformer ratios, type of relay(s), communication equipment applied for protection, and Protection System settings. The recipient will incorporate the applicable information into its PSCSs to evaluate whether changes are required.

The list of applicable changes provided in Requirement R3, Part 3.1 is inclusive, as it comprises either the protective equipment itself or the power system Elements that affect the coordination of Protection Systems. The drafting team recognizes that Facility changes at other locations can impact the PSCS of the Facility associated with the ~~Intereonected~~Interconnecting Element; e.g., the addition of a large autotransformer bank or generator not directly connected to the ~~Intereonected~~Interconnecting Element. The drafting team believes that it is not appropriate to specify a single time frame for providing the details of the wide variety of conditions listed in Requirement R3, Part 3.1 that may be associated with a particular change. This is because the drafting team sees the entity initiating any change as having the incentive to move the process along in a timely fashion in order to both keep the associated project on schedule ~~and confirm the changes are acceptable~~ “prior to the in-service date,” as stipulated by Requirement R4, Part 4.2.

Requirement R3, Part 3.2 allows for entities to agree upon a schedule, appropriate to the circumstances, for providing the details needed to conduct a PSCS or, absent such agreement, within 30 calendar days of a request for this information. This requirement provides a means for entities to receive requested information in a timely manner. In consideration of circumstances where the information may not be readily available or may be incomplete due the retirement of personnel, the purging of records, change of ownership, etc., it also provides the flexibility of mutually agreeing to a schedule for exchanging information. The drafting team believes 30 calendar days after receipt of the request is a sufficient amount of time to provide the requested information where no other agreement exists.

~~Additionally, this requirement~~Requirement R3, Part 3.3 includes a provision for providing details associated with changes to the previously agreed-upon coordination when permanent changes are made to Protection Systems during Misoperation investigations, commissioning, maintenance activities, or emergency replacements made due to failures of Protection System components. Based upon the limited number of instances that would occur under such circumstances, the drafting team believes 30 calendar days after determining that changes are required is an appropriate time frame for providing the associated details to affected entities.

Requirement R4:

Requirement R4 directs applicable entities, within 90 calendar days after receipt, to review the summary results of a PSCS or the technical justification, as described in Requirement R1, Part 1.2; and respond that they have reviewed and identified any issues. The drafting team believes 90 calendar days after receipt provides a reasonable time for the owners of Facilities to review.

Requirement R5:

The reliability objective of this requirement is to bring the process of Protection System coordination full circle by ~~gaining the confirmation of interconnected entities that their Protection Systems are coordinated consistent with the purpose of this standard. Cooperative participation of Facility owners in communicating Protection System(s) design, and study results will achieve coordination of Protection Systems for reliable operation of the BES during Faults.ensuring owners of Protection System(s) associated with Interconnecting Elements have communicated and addressed any identified coordination issues prior to implementing changes in the Protection System(s) (in-service date).~~

~~Requirement R4, Part 4.1 directs applicable entities, within 90 calendar days after receipt, to review the summary results of a PSCS, as described in Requirement R1, Part 1.2; and respond as to whether they accepting or rejecting the results, and if rejecting, suggesting modifications to resolve any identified coordination issues. The drafting team believes 90 calendar days after receipt of the results of a PSCS provides a reasonable time for the owners of Facilities to review the summary results of a PSCS.~~

~~Requirement R4, Part 4.2 directs entities to affirm that the other owner(s) of each Facility associated with the affected Interconnected Element have accepted the Protection System(s) changes as described in Requirement 3, Part 3.1 and Requirement 4, Part 4.1 prior to the in-service date of those changes. Any coordination issues identified during the review must be resolved prior to implementing the proposed changes. The purpose of Requirement 4, Part 4.2 is to assure the effects the proposed changes have on Protection Systems at a Facility associated with the Interconnected Element have been considered by all affected entities.~~

Application Guidelines

Process Flow Chart: Below is a complete representation of the process, including the relationships between requirements:

Note: All timeframes referenced in the diagram below represent “calendar month” or “calendar day” timeframes:

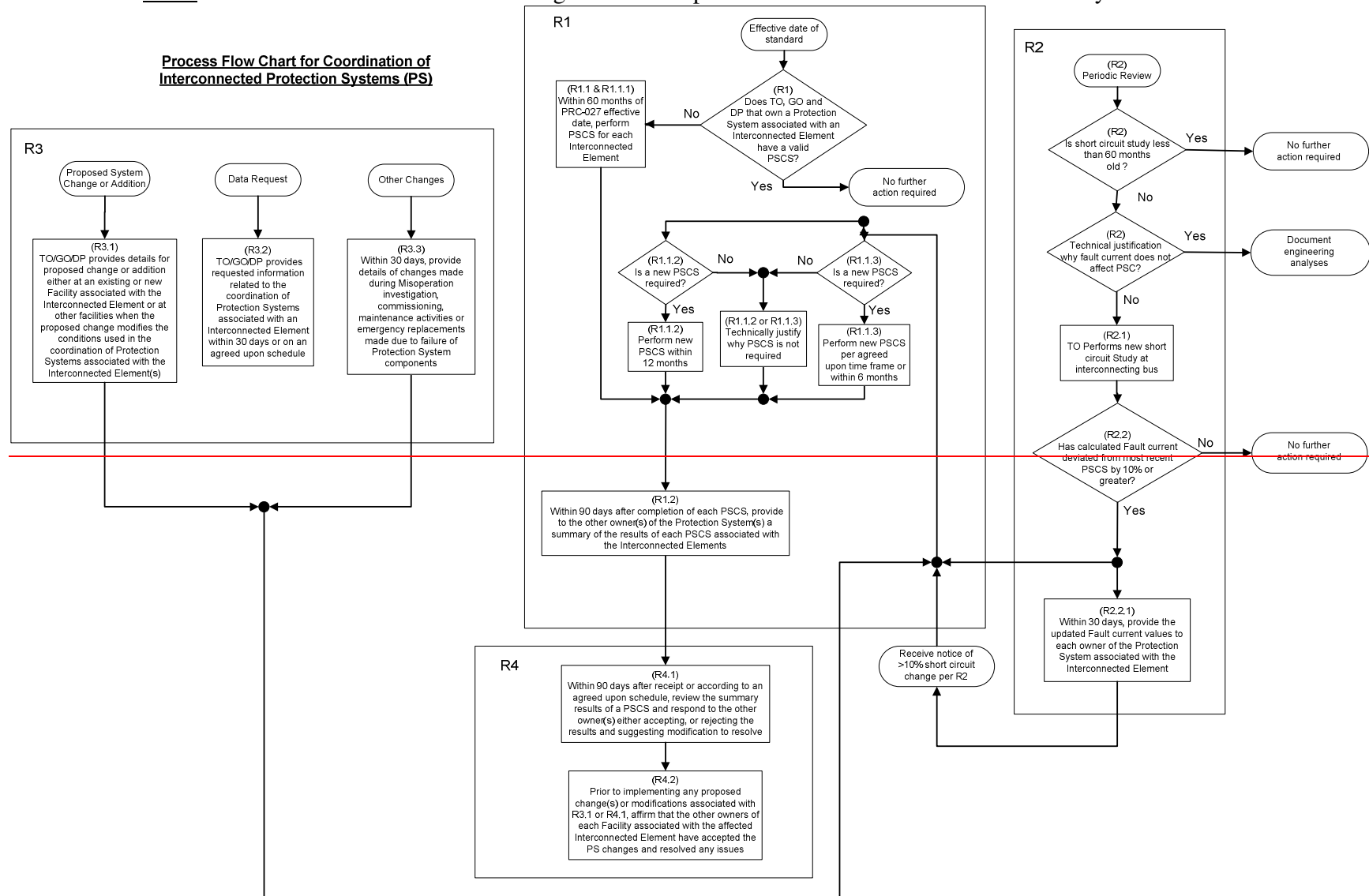

Process Flow Chart for Coordination of Interconnected Protection Systems (PS)

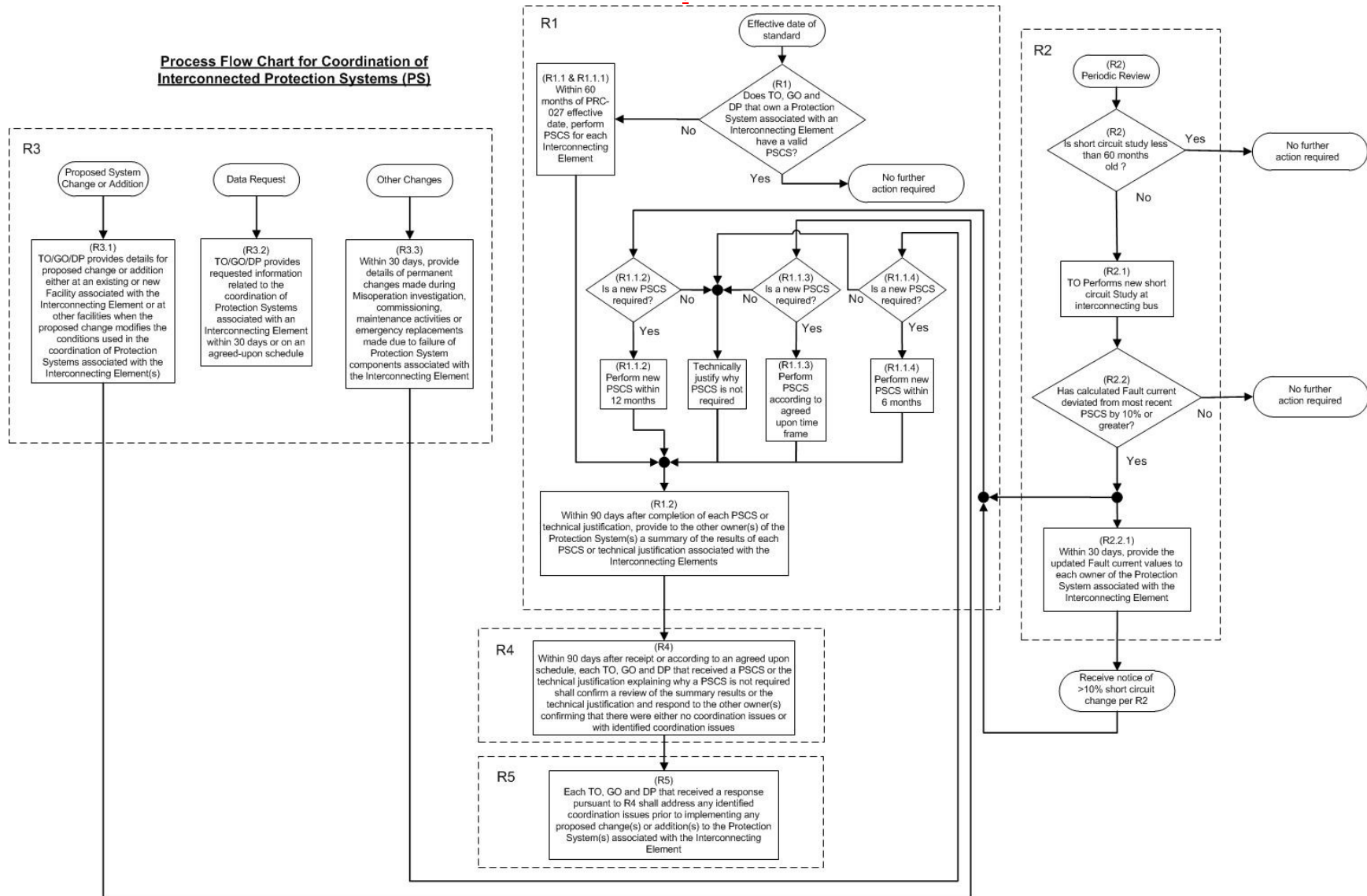

Example Process

An example of the interaction between entities required to gather the information to perform an accurate study is provided below. This example is given as general guidance only and is not intended to represent all situations that may occur. More detailed examples are provided along with Figures 1-5 in the section that follows this example.

- The initiating entity (Entity A) will contact the ~~interconnected~~interconnecting entity (Entity B) and provide details of the ~~proposed~~ change(s) and may also request up-to-date Protection System information.
- Entities A and B will determine whether a new PSCS is required. -In this example both agree that a new study is required.- The study may be a joint study, individual studies, or a single study provided by Entity A and reviewed and approved by Entity B. -In this example, the latter will occur.
- Upon receipt of the above request for information, Entity B will provide the information within 30 calendar days, or an agreed upon time frame.
- Entity A will perform a PSCS using the information received.
- Entity A will provide a summary of the results of the study to Entity B within 90 calendar days of completing the PSCS.
- Entity B will review the summary information and, within 90 calendar days of receiving the study results from Entity A, respond as to whether any coordination issues were identified, and if any further action is required.
 - In cases where the study reveals that changes to Protection Systems are needed, Entity B would propose to Entity A revisions that achieve acceptable results.
 - Ultimately, both entities will collaborate in developing a mutually acceptable solution.

Application Guidelines

Diagrams

Introduction: The diagrams below are intended to provide guidance, to the owners of Facilities associated with the affected Interconnected/Interconnecting Element, for meeting the requirements of this standard. These examples are not intended to be inclusive of all situations and are based on the assumption that entities employ the appropriate engineering expertise and due diligence in developing settings for their Protection Systems. The examples given also assume a single owner as the initiator of a Protection System Coordination Study (PSCS) for the applicable Interconnected/Interconnecting Element. In actuality, any owner or owners may initiate the process. After the reviews of the PSCS or a summary of results, and prior to implementation of changes, the owners must work together to resolve any coordination issues identified during those reviews.

NOTES:

1. Protection System Coordination Studies are typically performed assuming maximum generation and all Facilities in service.
2. Protection Systems of the Transmission Owners, Generator Owners, and Distribution Providers described in the Figures and examples below do not include any systems or components enumerated in the 'Background Section' of this standard under "Other Aspects of Coordination of Protection Systems Addressed by Other Projects".
3. In the Figures below, the locations of the interconnecting bus(s) referenced in Requirement 2 are indicated.

Figure 1

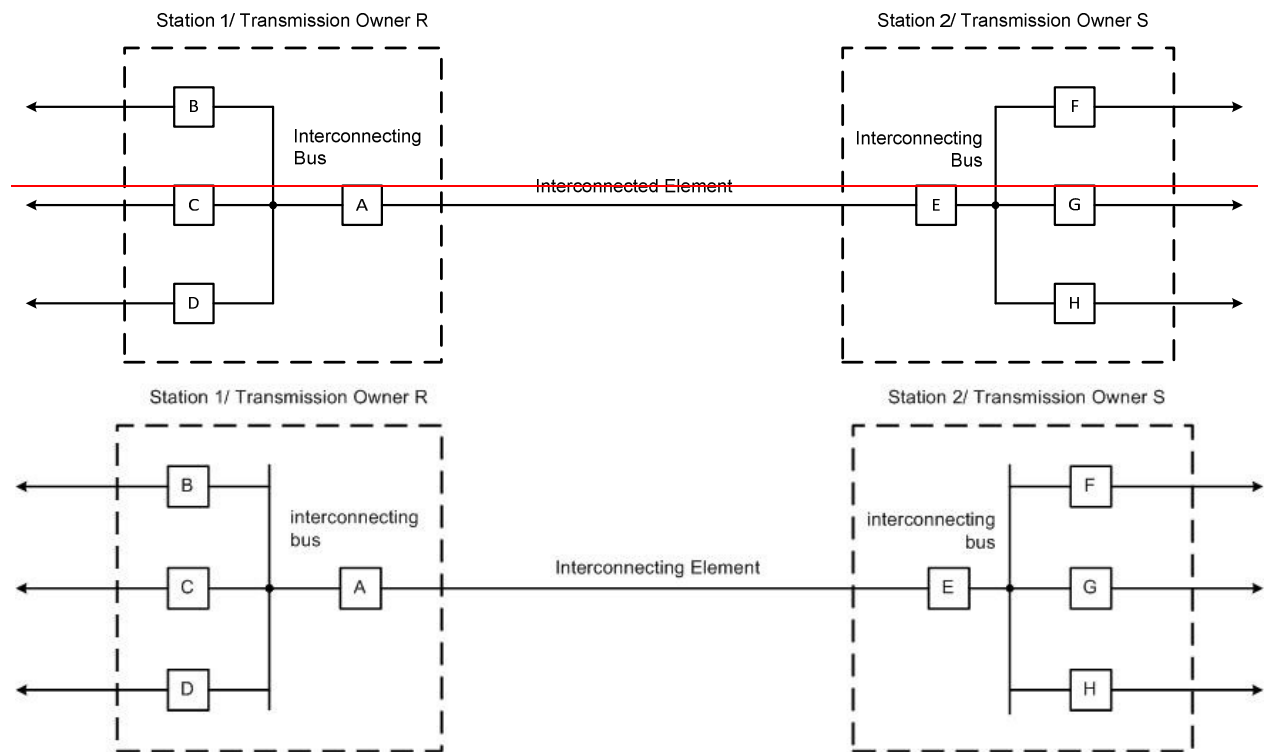

Application Guidelines

| In Figure 1 above, the ~~Interconnected~~Interconnecting Element between the Transmission Owners is the transmission line between Breakers A and E.

Example: For the purposes of conducting the PSCS associated with the Facilities in Figure 1, Owner S is to review the Protection System settings associated with Breaker A (provided by Owner R) for coordination issues with the Protection System settings associated with Breakers E, F, G, and H. Likewise, Owner S is to develop ~~proposed~~ Protection System settings associated with Breaker E. Owner R is to review the Protection System settings associated with Breaker E (provided by Owner S) for coordination issues with the Protection System settings associated with Breakers A, B, C, and D.

Figure 2

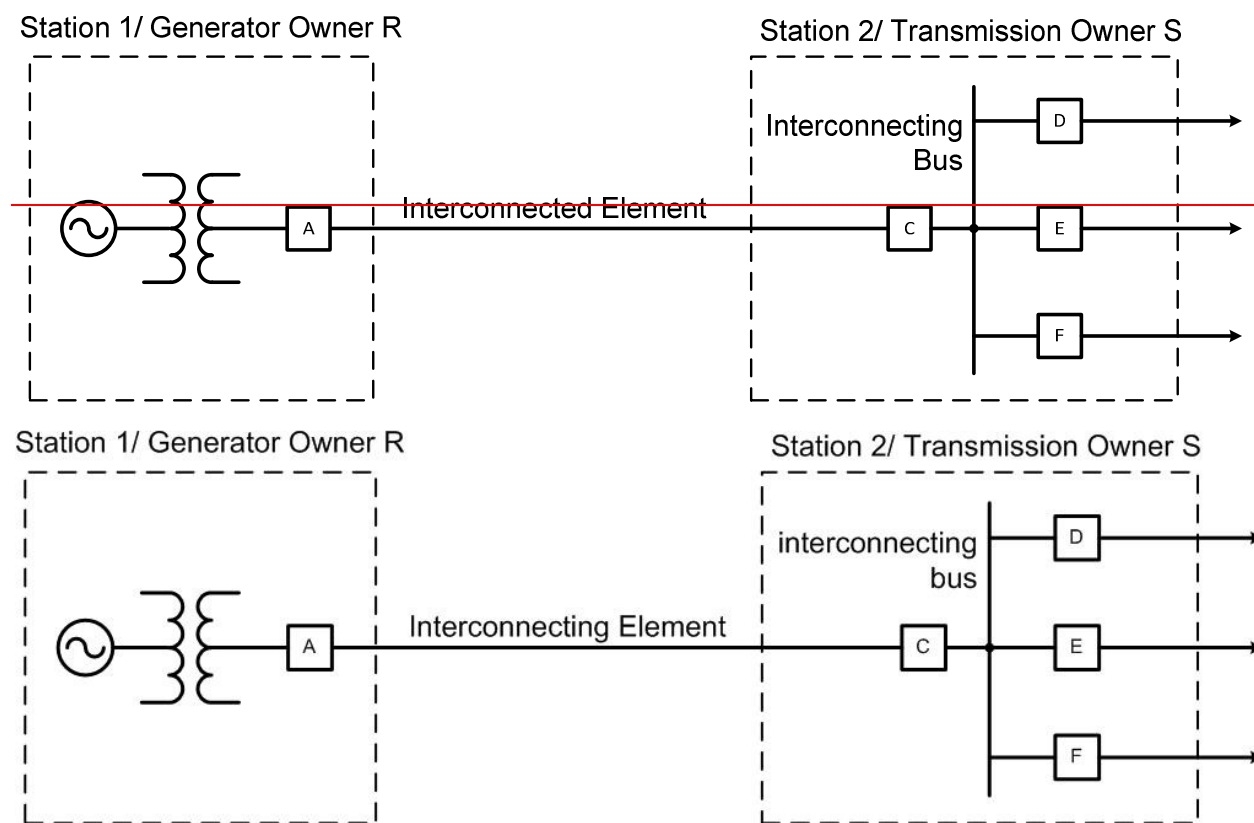

In Figure 2 above, the ~~Interconnected~~Interconnecting Element between the Transmission Owner and the Generator Owner is the transmission line or bus between Breakers A and C.

Note: Depending on the actual configuration and/or ownership, Breaker A may, or may not, exist as a GSU unit high-side breaker or a line breaker.

Example: For the purposes of conducting the PSCS associated with the Facilities in Figure 2, Owner R is to develop ~~proposed~~Protection System settings associated with Breaker A.

Transmission Owner S is to review the Protection System settings associated with Breaker A (provided by Owner R) and the generator Protection Systems for coordination issues with the Protection System settings associated with Breakers C, D, E, and F. Likewise, Owner S is to develop ~~proposed~~Protection System settings associated with Breaker C. ~~Generation Generator~~ Owner R is to review the Protection System settings associated with Breaker C (provided by Owner S) for coordination issues with the Protection System settings associated with Breaker A or the generator Protection Systems.

Figure 3

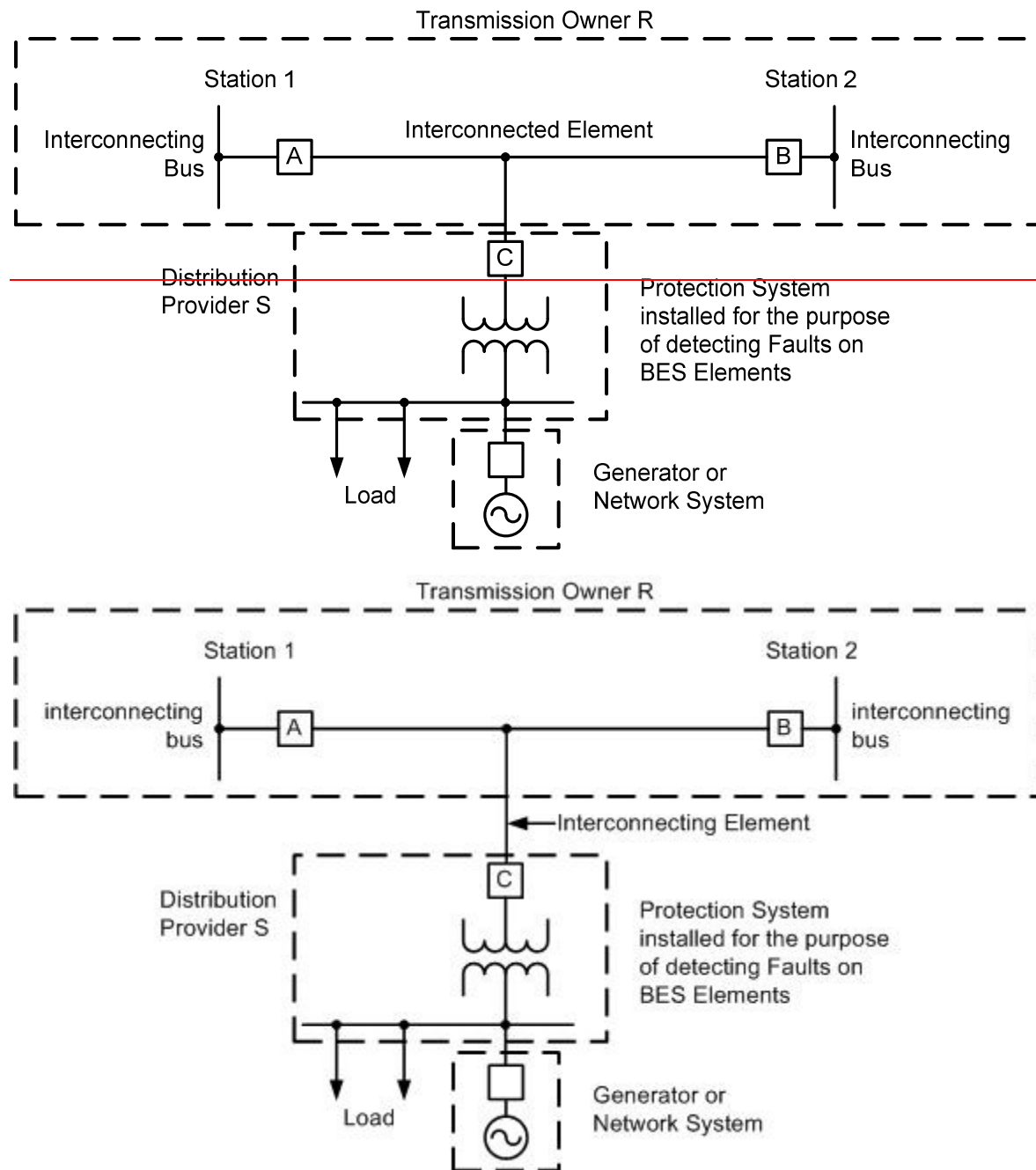

In Figure 3 above, the ~~Interconnected~~Interconnecting Element between the Transmission Owner and the Distribution Provider is the transmission line (or tap) between the Distribution Provider's Breaker C and the point of connection to the line between the Transmission Owner's Breakers A and B. Therefore, the applicable Protection Systems per this standard are those at Breakers A, B and C.

Example: For the purposes of conducting the PSCS associated with the Facilities in Figure 3, Distribution Provider S is to develop ~~proposed~~ Protection System settings associated with Breaker C. Transmission Owner R is to review the Protection System settings associated with

Application Guidelines

Line Breaker C (provided by Distribution Provider S) for coordination issues with the Protection System settings associated with Breakers A and B and other Protection Systems at stations 1 and 2.

Notes:

A PSCS is required per this standard for this example if a Protection System at the Distribution Provider's substation is installed for the purpose of detecting Faults on BES Elements.

Protection Systems installed for the purpose of detecting Faults on BES Elements do not include relays that, though they may operate for such Faults, are not installed specifically for that purpose. As an example, reverse power relays are often installed to detect situations where the transmission source for a power transformer becomes de-energized (for whatever reason) while the distribution bank remains energized from a source on the low-voltage side. In this case, the settings of the reverse power relay are typically calculated based on the charging current of the transformer from the low-voltage side. Although relays installed and set in this manner may operate as a result of a Fault on a BES Element, they are not specifically installed for the purpose of detecting that Fault.

Figure 4

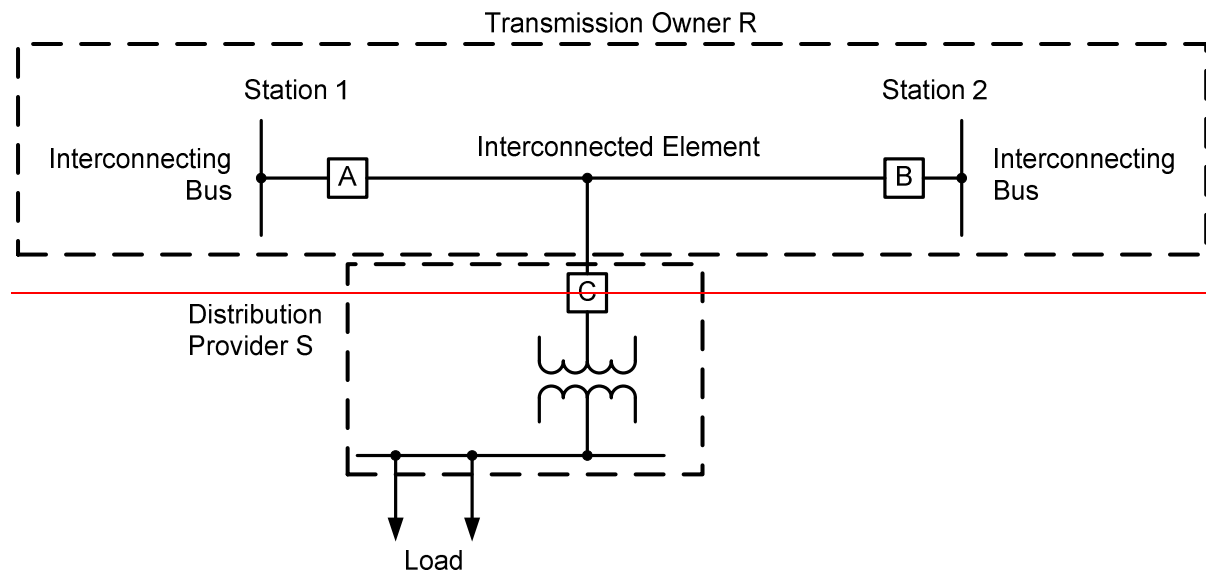

In Figure 4

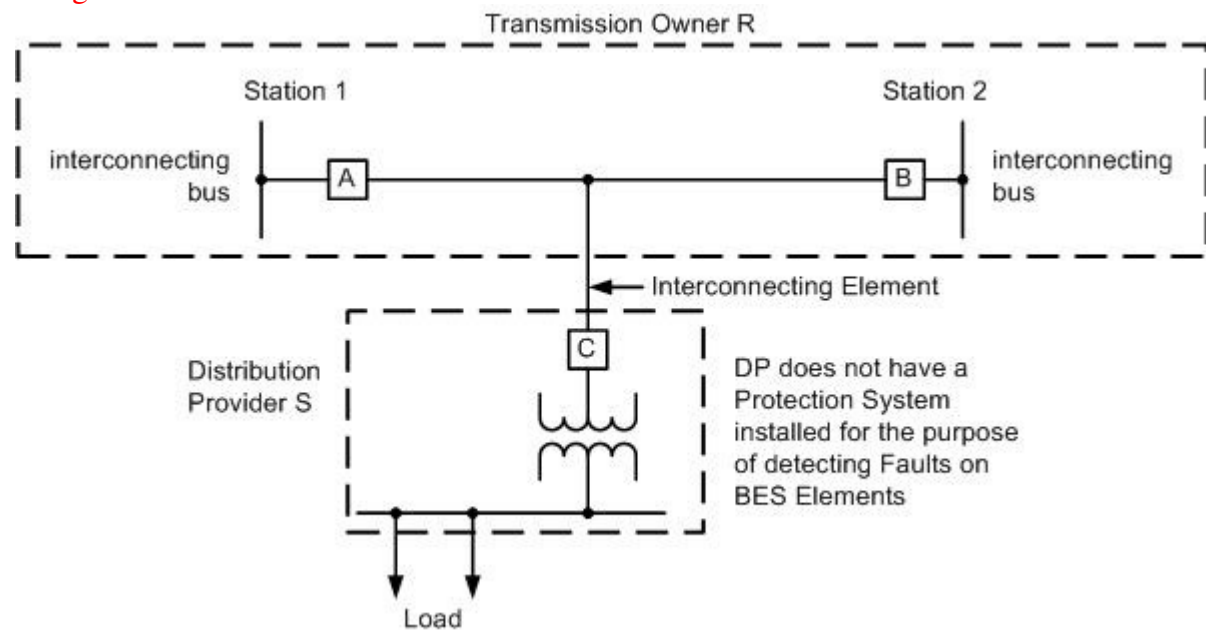

The configuration above, ~~the Interconnected Element between the Transmission Owner and is an example excluded from this standard because the Distribution Provider is the transmission line or tap between the line and Breaker C.~~

~~Note: No specific PSCS is required per this standard for this example since the S does not own Protection System at the Distribution Provider's substation is not Systems installed for the purpose of detecting Faults on BES Elements.~~

Application Guidelines

Figure 5

Transmission/Generation Facility with Multiple Owners

Note: In a large majority of cases, Figure 2 would be applicable for most generator interconnections. In Figure 5 below, Transmission Owner S has no direct Protection Systems located at Station 1 that need to be checked for coordination with Generator Owner T.

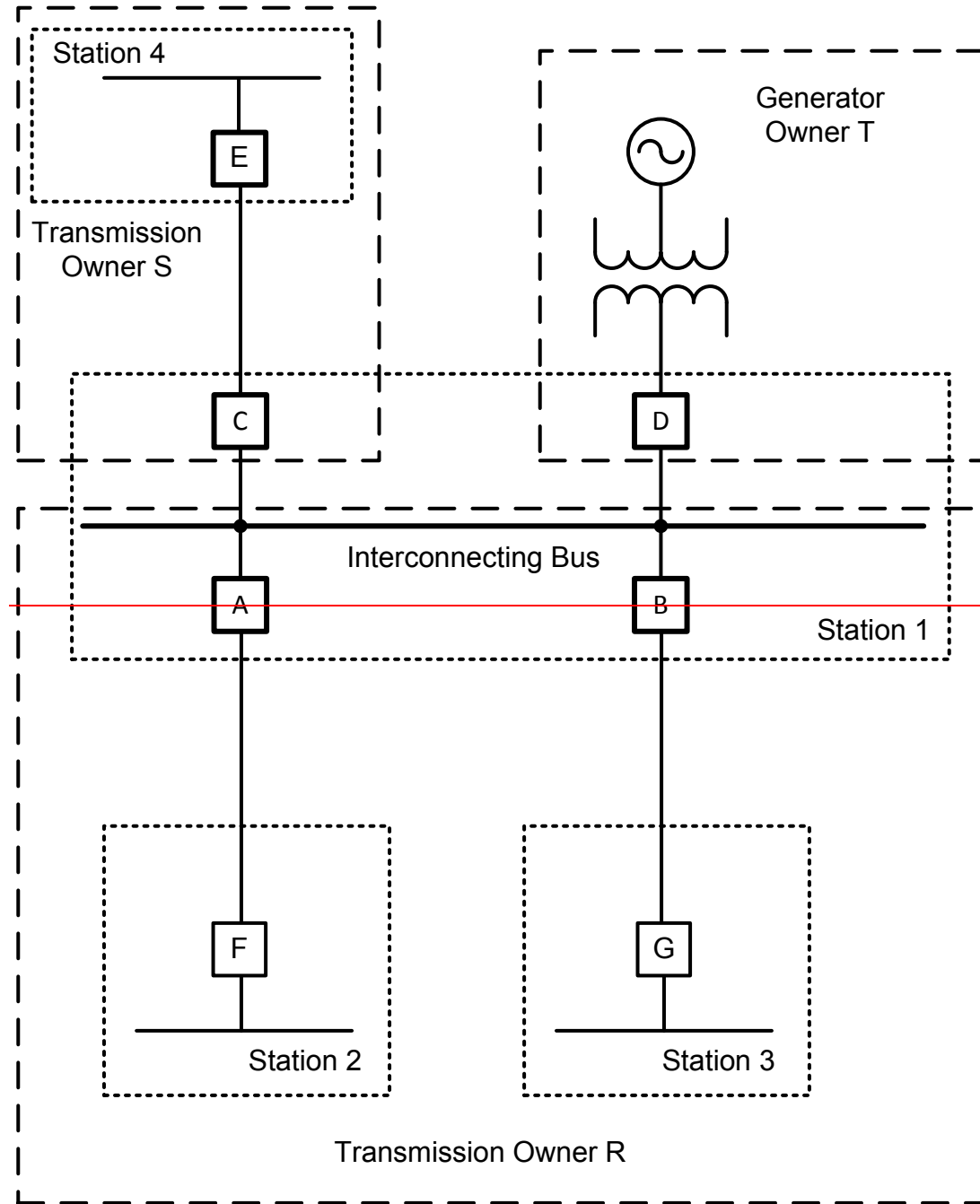

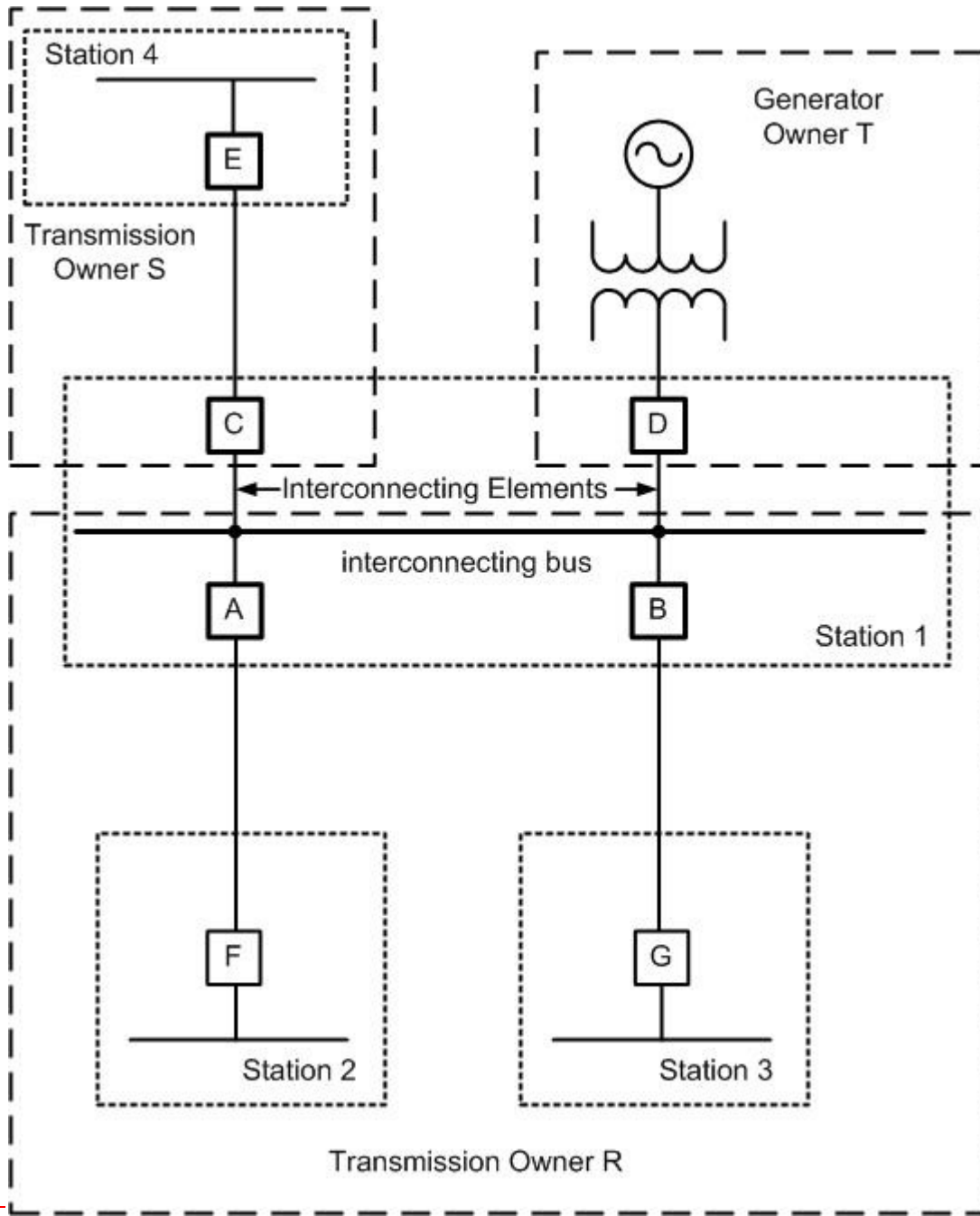

In

Figure 5 above, illustrates the Interconnecting Elements between the Transmission Owners R and S and Generator Owner T ~~is the common Transmission bus.~~ In this example, Transmission Owner S and Generator Owner T are not directly interconnected interconnecting to each other at Station 1. All direct interconnections are between Owner R and each of the other Owners connected to the common bus at Station 1.

Example: For the purposes of conducting the PSCS associated with the Facilities in Figure 5:

Owner S is to develop ~~proposed~~ Protection System settings associated with Breakers C and E.

Application Guidelines

| Owner T is to develop ~~proposed~~ Protection System settings associated with Breaker D, the generator, and its associated equipment.

| Owner R is to develop ~~proposed~~ Protection System settings associated with Breakers A, B, F and G.

Owner R is to review the Protection System settings associated with Breaker C, E, D, and the generator Protection System (provided by Owners S and/or T) for coordination issues with the Protection System settings associated with Breakers A and B.

Owner S is to review the Protection System settings associated with Breakers A, F, B, G, D, and the generator Protection System (provided by Owners R and/or T) for coordination issues with the Protection System settings associated with Breaker C. To perform this review, it will be necessary that Transmission Owner R provide Owner S with its settings for Breakers A, F, B, and G, as well as the settings for Breaker D and generator Protection System settings provided to Owner R by Generator Owner T.

Owner T is to review the Protection System settings associated with Breakers A, F, B, G, C, and E (provided by Owners R and/or S) for coordination issues with the Protection System settings associated with Breaker D or the generator Protection System. In order to perform this review, it will be necessary that Transmission Owner R provide Generator Owner T with its settings for Breakers A, F, G, and B, as well as the settings for Breaker C and E provided to Owner R by Transmission Owner S.